



User Guide

MD500E AC Drive

High Performance, Open and Closed Loop



Preface

Thank you for purchasing the MD500E Series AC Drive developed by Inovance Technology!

It is a general-purpose and high-performance current vector AC drive technically upgraded from the MD380E series. It is mainly used for controlling and adjusting the speed and torque of three-phase AC synchronous motor. Using high-performance vector control technology, the MD500E Series AC drive features high torque output at a low speed, excellent dynamic characteristics and superior overload capability. It provides user-programmable features and background monitoring software and communication bus functions and supports multiple PG cards, delivering rich and powerful combined functions and stable performance. It can be used to drive multiple kinds of automated production equipment.



Product appearance

§ First Use

Please read this manual carefully if you use the AC drive for the first time. For any doubt on its function or performance, please contact our technicians for help.

§ Standards Compliance

The following table lists the certificates and standards that the product may comply with. For details about the acquired certificates, see the certification marks on the product nameplate.

Name	Directive Name		Standard
CE certification	EMC Directive	2014/30/EU	EN 61800-3
	LVD Directive	2014/35/EU	EN 61800-5-1
	RoHS Directive	2011/65/EU	EN 50581
TUV certification	-		EN 61800-5-1
UL certification	-		UL61800-5-1 C22.2 No.14-13

Note

- The IEC/EN 61800-3 standard is complied with only when the AC drive is correctly installed and used. For details, refer to "2 System Connection" and common EMC problem rectification.

Revision History

Date	Version	Change Description
Dec 2015	V0.0	<ul style="list-style-type: none">• Related firmware version: F7-10 = U0.54 and F7-11 = U1.54.
Nov 2016	A01	<ul style="list-style-type: none">• Modified Approvals, designation rule and nameplate.
Nov 2017	A02	<ul style="list-style-type: none">• Add the 0.4 to 15 kW models• Delete the MDKE7 keyboard and add the MDKE9 keyboard
April 2019	A03	<ul style="list-style-type: none">• Updated the cover.• Updated certification description in Preface.

§ Manual and Acquisition



This Manual is delivered with the product. If you want to purchase another copy, please contact your product distributor.



Please visit the official website (<http://www.inovance.com>) of Inovance Technology to download the PDF version.

Safety Information

§ Safety Precautions

1. Please read and follow the safety precautions when installing, operating and maintaining the product.
2. To ensure your safety and prevent damage to equipment, please follow the marks on the product and safety precautions in this manual when installing, operating and maintaining the product.
3. "CAUTION", "WARNING", and "DANGER" items in the manual do not indicate all safety precautions that need to be followed; instead, they just supplement the safety precautions.
4. Use this product in environment meeting the design and specification requirements; otherwise, a fault may occur. Noncompliance-caused malfunction or damage to parts are not covered in product quality warranty.
5. Inovance is not legally responsible for any personal safety accident or property losses caused by improper operation of this product.

§ Safety Grade and Definition

The  **Danger** "DANGER" indicates the improper operation, which, if not avoided, causes death or serious injury.

The  **Warning** "WARNING" indicates the improper operation, which, if not avoided, may cause death or serious injury.

The  **Caution** "CAUTION" indicates the improper operation, which, if not avoided, may cause minor injury or equipment damage.

§ Safety Information

Unpacking and Checking

Danger

- ◆ Before unpacking, check whether the outer package is intact, damaged, wet, damped, or deformed.
- ◆ Open the package in sequence. Violent beating is prohibited!
- ◆ During unpacking, check whether the product and its accessories have any damage, corrosion or bump on the surface.
- ◆ Check the quantity of the product and its accessories and data completeness according to the packing list.

Warning

- ◆ Do not install the product and its accessories when you find that the product and its accessories have any damage or corrosion or they have been used.
- ◆ Do not install the product when there is water inside the product or any of its parts is missing or damaged.
- ◆ Do not install the product when the product name is inconsistent with that in the packing list.

During Storage and Transportation

 **Warning**

- ◆ Store and transport the product according to its storage and transportation conditions. The storage temperature and humidity shall meet relevant requirements.
- ◆ Do not store or transport the product in places with direct sunlight, strong electric field, strong magnetic field or strong vibration or places that are wet by rain or splashing water.
- ◆ Do not store the product for over three months. Take stricter prevention measures and perform necessary inspection when the storage time is too long.
- ◆ Well pack the product before transportation. The product must be placed in a sealed box for long-distance transportation.
- ◆ Do not transport the product together with any equipment or articles that may affect or impair the product.

 **Caution**

- ◆ Be sure to use professional loading and unloading equipment to move large or heavy equipment and products!
- ◆ When moving the product by hand, grab the product case tightly to avoid dropping the product parts, causing injury!
- ◆ Be sure to move the product lightly, pay attention to your step to prevent trip or fall; otherwise, there is the risk of injury or damage to the product!
- ◆ When the equipment is lifted by a lifting gear, do not stand or stay in the area below the lifting area.

During Installation

 **Caution**

- ◆ Before installation, carefully read the product manual and safety precautions!
- ◆ Do not modify the product!
- ◆ Do not unscrew the fixing bolts and bolts with red mark of the product parts and components!
- ◆ Do not install this product in a place with strong electric field or strong electromagnetic interference!
- ◆ When the product is installed in a cabinet or terminal equipment, the cabinet or terminal equipment shall be provided with the corresponding protective devices such as fireproof enclosure, electrical enclosure and mechanical enclosure. The protection grade shall comply with relevant IEC standards and local laws and regulations.

 **Danger**

- ◆ Non-professionals are strictly prohibited from product installation, wiring, maintenance, inspection or parts replacement!
- ◆ These operations can only be done by professionals trained on electrical equipment and having knowledge of electrical equipment.
- ◆ Installers must be familiar with product installation requirements and related technical data.
- ◆ When you need to install equipment, such as transformers, having strong electromagnetic interference, install the shield protection device to prevent the product from malfunction!

During Wiring

 **Danger**

- ◆ Non-professionals are strictly prohibited from equipment installation, wiring, maintenance, inspection or parts replacement!
- ◆ Do not perform wiring when the power is turned on. Failure to comply may result in electric shock.
- ◆ Before wiring, cut off the power of all equipment. There is residual voltage in internal capacitor of the equipment after the power is cut off. Wait for at least 10 minutes before wiring and other operations.
- ◆ Be sure the equipment and product are properly grounded. Failure to comply may result in electric shock.
- ◆ Follow the ESD precautions and wear EDS wrist strap to avoid damage to the equipment or circuit inside the product.

 **Warning**

- ◆ It is prohibited to connect the input power to the output terminal of the equipment or product; otherwise, the equipment may be damaged or fire may occur.
- ◆ When connecting a driving equipment to the motor, be sure that the phase sequence of the driver and the motor terminal are consistent, so as to avoid reverse rotation of the motor.
- ◆ The cables used for wiring must meet relevant diameter and shielding requirements, and the shielding layer of the shielding cables must be reliably grounded at single terminal!
- ◆ After wiring is finished, be sure there is no screw or bar cables inside the equipment and product.

During Power-on

 **Warning**

- ◆ Before power-on, be sure the equipment and product are installed properly, the wiring is firm and the motor unit is allowed to restart.
- ◆ Before power-on, be sure the power supply meets the equipment requirements to avoid damage to the equipment or causing fire!
- ◆ During power-on, mechanical devices of the equipment or product may suddenly move. Stay away from the mechanical devices.
- ◆ After power-on, do not open the equipment cabinet door or product protection cover; otherwise, there is the danger of electric shock!
- ◆ It is prohibited to touch any terminal of the equipment when power is on; otherwise, there is the danger of electric shock!
- ◆ It is prohibited to dismantle any device or parts of the equipment and product when the power is on; otherwise, there is the danger of electric shock!

During Running

 **Danger**

- ◆ It is prohibited to touch any terminal of the equipment when it is running; otherwise, there is the danger of electric shock!
- ◆ It is prohibited to dismantle any device or parts of the equipment and product when the equipment is running; otherwise, there is the danger of electric shock!
- ◆ It is prohibited to touch the equipment closure, fan or resistor to check the temperature; otherwise, there is the danger of burn!
- ◆ Non-professional technicians are prohibited to detect the signal when the equipment is running; otherwise, there is the danger of personal injury or damage to the equipment!

 **Warning**

- ◆ When the equipment is running, do not drop other articles or metals into the equipment; otherwise, the equipment may be damaged!
- ◆ Do not start or stop the equipment by turning on or off the connector; otherwise, the equipment may be damaged!

During Maintenance

 **Danger**

- ◆ Non-professionals are strictly prohibited from equipment installation, wiring, maintenance, inspection or parts replacement!
- ◆ It is prohibited to maintain the equipment when power is on; otherwise, there is the danger of electric shock!
- ◆ After the equipment power is cut off, wait for at least 10 minutes before maintaining the equipment or performing other operations.

 **Warning**

- ◆ Follow the equipment maintenance and repair requirements for routine and regular inspection and maintenance of the product and equipment, and prepare the maintenance records.

During Repair

 **Danger**

- ◆ Non-professionals are strictly prohibited from equipment installation, wiring, maintenance, inspection or parts replacement!
- ◆ It is prohibited to repair the equipment when power is on; otherwise, there is the danger of electric shock!
- ◆ After the equipment power is cut off, wait for at least 10 minutes before inspecting or repairing the equipment or performing other operations.

 **Warning**

- ◆ Repair the equipment according to the product warranty agreement.
- ◆ When the equipment has fault or is damaged, troubleshoot and repair the equipment and product follow guidance by professionals, and prepare the repair records.
- ◆ Replace the product wearing parts under guidance.
- ◆ Do not continue to use damaged machines; otherwise, greater damager may be caused.
- ◆ After replacing the equipment, re-check the equipment wiring and parameter settings again.

During Scrapping

 **Warning**

- ◆ Scrap the equipment and product according to national regulations and standards to avoid property loss or personal injury!
- ◆ Recycle scrapped equipment and product according to industrial waster processing standards to avoid pollution to the environment.

§ Safety Marks

For safe operation and maintenance of the equipment, be sure to observe the safety marks affixed to the equipment and product. Do not damage, destroy or peel off the safety marks. Safety marks are described as follows:

Safety Marks	Description
	<ul style="list-style-type: none"> ◆ Read the user manual before installing and running the equipment; otherwise, there is the danger of electric shock! ◆ Do not dismantle the cover within 10 minutes after the power is turned on or cut off! ◆ After cutting off the power at the input and output terminals, wait for 10 minutes until the power indicator turns off before maintaining, inspecting or wiring the equipment.

Contents

Preface	1
Revision History	2
Safety Information	3
1 Product Information.....	11
1.1 Nameplate and Model	11
1.2 Description of Parts	12
2 System Connection	17
2.1 MD500E System Connection Diagram	18
2.2 MD500E Series System Composition.....	19
3 Installation and Wiring.....	20
3.1 Installation	20
3.1.1 Installation environment.....	20
3.1.2 Mounting Clearance and Orientation	21
3.1.3 Installation of MD500ET0.4GB to MD500ET160G	23
3.1.4 Mounting in Cabinet.....	27
3.1.5 Remove and Refit the Cover.....	35
3.2 Wiring	38
3.2.1 Standard Wiring Diagram	38
3.2.2 Functions of Main Circuit Terminals and Precautions	39
3.2.3 Main Circuit Terminal Arrangement and Dimensions	45
3.2.4 Control Board	54
3.2.5 Control Circuit Terminal Arrangement	55
4 Panel Operation	57
4.1 Introduction	57
4.2 LED Operating Panel	57
4.2.1 Indicators on LED Operating Panel	58
4.2.2 LED Display.....	59
4.2.3 Keys on LED Operating Panel.....	59
4.2.4 View and Modify Function Parameters	60
4.2.5 Overall Arrangement of Function Parameters.....	61
4.2.6 View Function Parameters.....	62
4.2.7 MF.K Key Function	67
4.3 External LCD Operating Panel	68
5 Basic Operations and Trial Run	69
5.1 Quick Commissioning Guide	69
5.2 Commissioning Flowchart	70
5.3 Checklist Before Power-on.....	73
5.4 Display After Power-on.....	73
5.5 Parameter Initialization	73
5.6 Motor Control	74

5.7 Start/Stop running command.....	74
5.7.1 Start/Stop Operating Panel.....	74
5.7.2 Start/Stop DI.....	74
5.7.3 Start/Stop via Communication	77
5.8 Start the AC Drive	77
5.8.1 Start Mode.....	77
5.8.2 Start Frequency.....	78
5.9 View Running Status	78
5.9.1 Digital Output (DO).....	78
5.9.2 Analog Output (AO).....	79
5.10 Auto-tuning.....	80
6 Troubleshooting and Solutions.....	81
6.1 Safety Information.....	81
6.2 Troubleshooting During Trial Run.....	82
6.3 Fault Display	83
6.4 Resetting Fault.....	84
6.5 Faults and Diagnostics.....	85
6.6 Symptoms and Diagnostics.....	91
7 Routine Inspection and Maintenance.....	93
7.1 Routine Inspection.....	93
7.1.1 Routine Inspection Items	94
7.2 Periodic Inspection	94
7.2.1 Periodical Inspection Items.....	94
7.2.2 Insulation Test on Main Circuit.....	95
7.3 Replacement of Wear Parts	95
7.3.1 Lifetime of Wear Parts	95
7.3.2 Number of Fans on the Drive.....	96
7.3.3 Replacement of Fans.....	97
7.3.4 DC Bus Electrolytic Capacitors.....	101
7.4 Storage.....	101
7.5 Warranty	101
8 Specifications and Model Selection.....	102
8.1 Technical Specifications of MD500E Series AC Drive.....	102
8.2 Appearance and Dimensions of MD500E Series AC Drive.....	107
8.2.1 Overall Dimensions of MD500ET0.4GB to MD500ET160G	107
8.2.2 Overall Dimension of MD500ET0.4GB to MD500ET160G with Through Hole Mounting Bracket.....	109
8.2.3 Overall Dimensions of MD500ET200G to MD500ET450G	118
8.2.4 Overall Dimensions of MD500ET200G-L to MD500ET450G-L	119
8.2.5 Dimensions of Mounting Bracket of MD500ET200G(-L) to MD500ET450G(-L).....	120
8.3 Options.....	121
8.4 Cables, Breakers, and Contactors.....	123

8.5 Braking Unit.....	124
8.5.1 Selection of Resistance of Braking Resistor	124
8.5.2 Selection of Power of Braking Resistor.....	124
8.5.3 Braking Units	125
8.5.4 Appearance and Mounting Dimensions of Braking Units	127
8.5.5 Appearance and Mounting Dimensions of the AFE Unit	128
8.6 AC Output Reactor	130
8.7 Applicable Motor.....	131
8.8 Mounting Dimensions of External Operating Panels	132
Appendix A Expansion Optional Cards.....	133
A.1 Installation and Function Guidelines	133
A.1.1 Installation.....	133
A.1.2 Functions	134
A.2 Layout and Function of Terminals of Extension RS485 Card (MD38TX1).....	134
A.3 Layout and Function of Terminals of MD38IO1	135
A.4 Layout and Function of Terminals of MD38IO2	138
A.5 Use of Extension Encoder Cards	139
A.5.1 Specifications of Extension Encoder Cards.....	139
A.5.2 Multifunctional PG Card (MD38PGMD).....	141
A.5.3 Differential Input PG Card (MD38PG1)	143
A.5.4 Resolver PG Card (MD38PG4)	144
A.5.5 Extension Open-collector PG Card (MD38PG5 and MD38PG5D).....	145
A.5.6 Extension Differential PG Card with Frequency Dividing (MD38PG6 and MD38PG6D).....	147
A.5.7 Shield Grounding of PG Card.....	148
A.5.8 EMC Guidance.....	148
Appendix B Definition of Communication Data Address and Modbus	
Communication Protocol.....	149
B.1 Definition of Communication Data Address	149
B.1.1 Parameter Data.....	149
B.1.2 Non-parameter Data.....	150
B.2 Modbus Communication Protocol	152
B.2.1 Application.....	152
B.2.2 Bus Structure	152
B.3 Data Format.....	152
B.4 Rules for Parameter Address Marking	155
B.5 Group FD Communication Parameter Description	158
Appendix C Parameter Table	159
C.1 Standard Parameter Table.....	159
C.2 Monitoring Parameters	189

1 Product Information

Safety Information



Caution

- ◆ Do not lift/carry the drive by carrying the front cover. Failure to comply may result in personal injury.
- ◆ Follow proper electrostatic discharge (ESD) procedures when operating the drive. Failure to comply will risk damaging the internal circuit of the drive.

1.1 Nameplate and Model

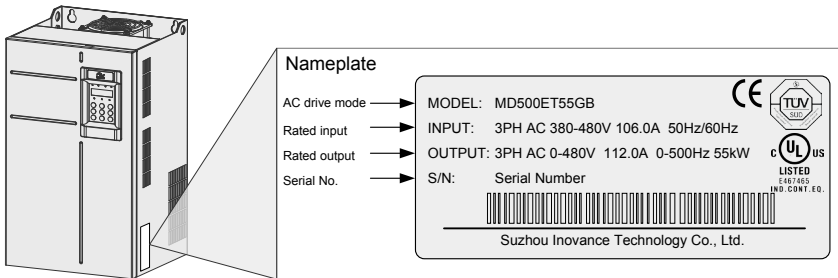

AC drive model

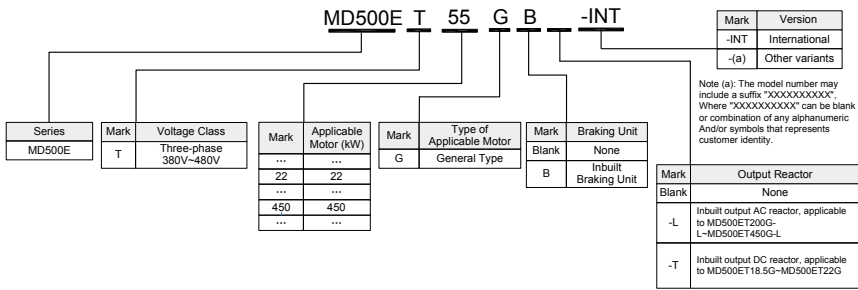
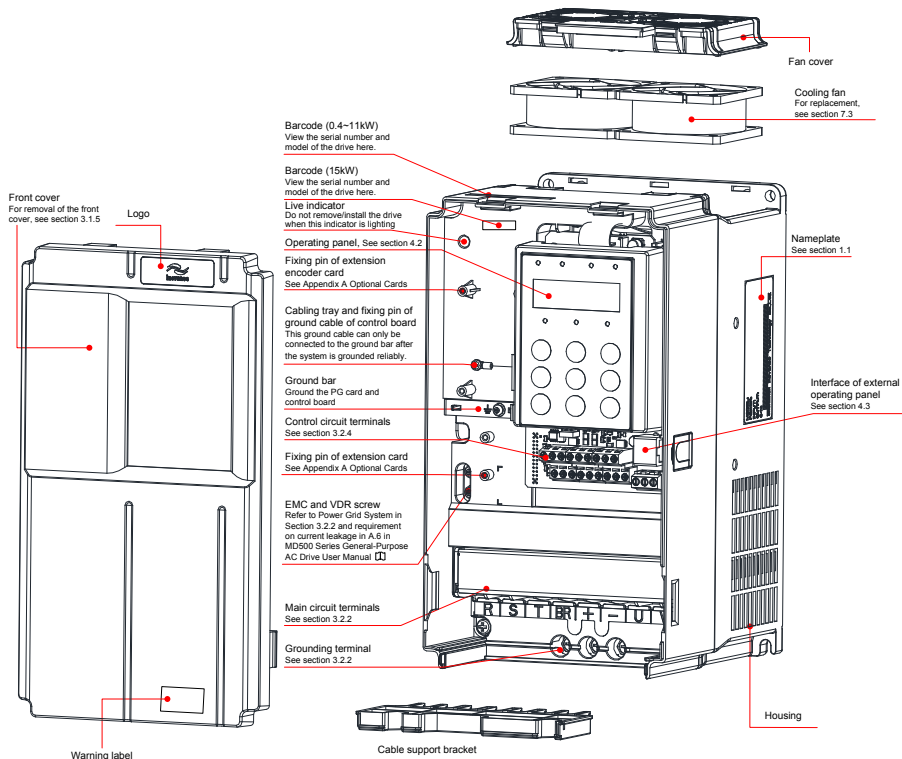

Figure 1-1 Product naming and nameplate

1.2 Description of Parts

The drive can have either a plastic housing or a sheet metal housing, depending on the voltage and power rating, as shown in the following figures:







Warning label	Description
 	CAUTION! Read the user guide of the AC drive carefully before installation or operation.
 	DANGER! Do not remove the front cover while the power is on or within 10 minutes after the power is turned off.

Figure 1-2 Schematic diagram of product parts (three-phase, 380V - 480V, MD500ET0.4GB to MD500ET15GB)

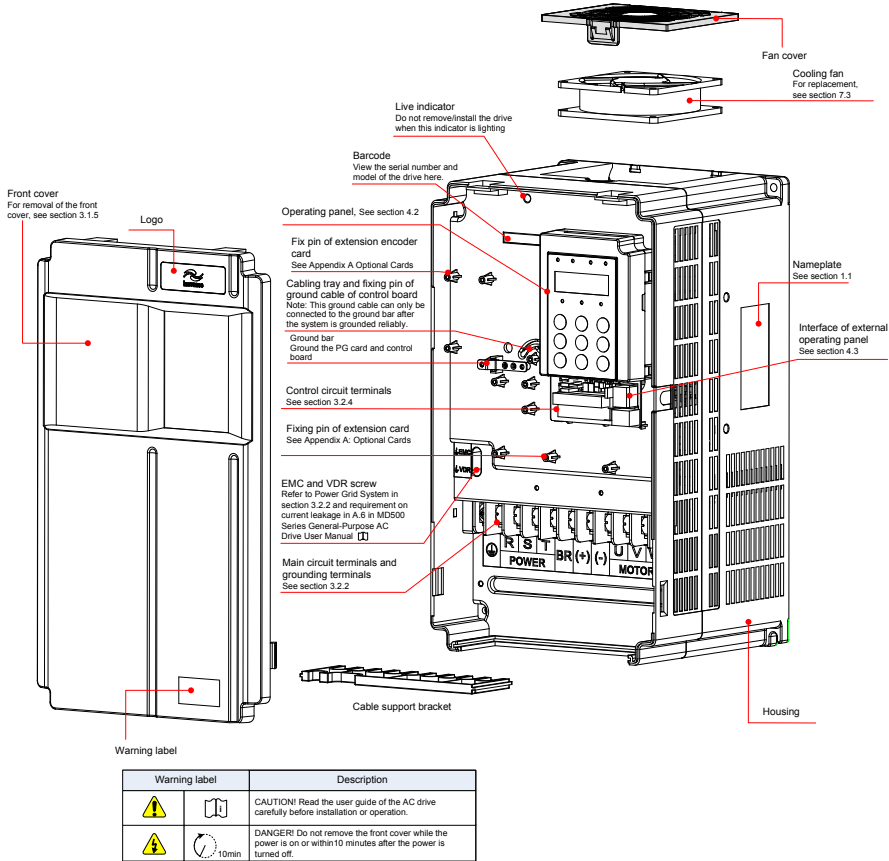
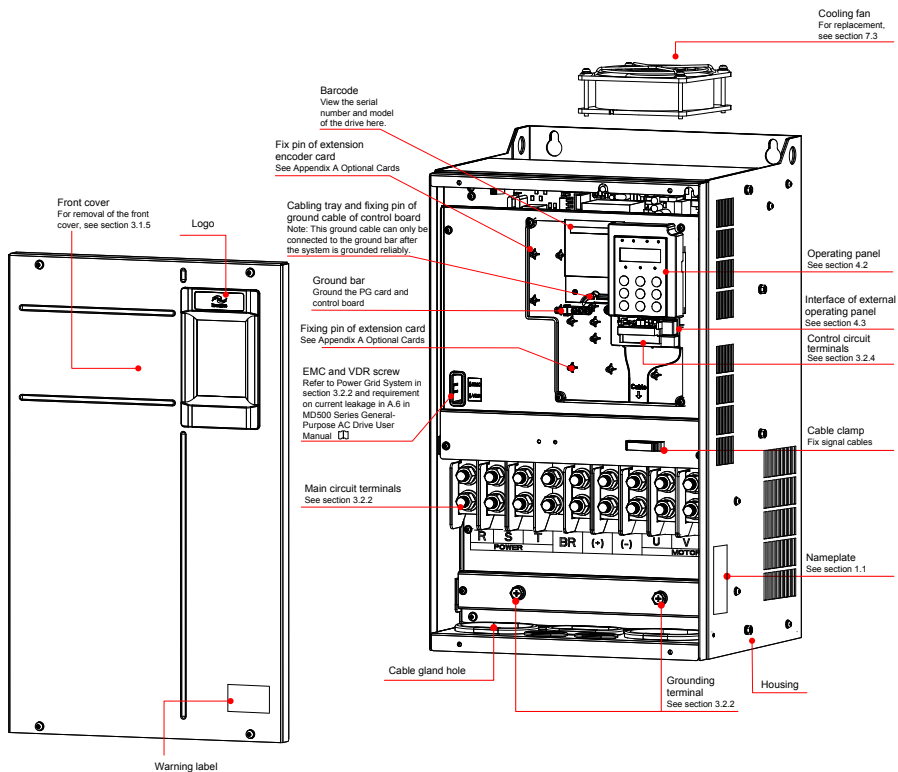

Figure 1-3 Schematic diagram of product parts (three-phase, 380V - 480V, MD500ET18.5G(B) to MD50037G(B))







Warning label	Description
	 CAUTION! Read the user guide of the AC drive carefully before installation or operation.
  10min	DANGER! Do not remove the front cover while the power is on or within 10 minutes after the power is turned off.

Figure 1-4 Schematic diagram of product parts (three-phase, 380V - 480V, MD500ET45G(B) to MD500ET160G)



Warning label		Description
		CAUTION! Read the user guide of the AC drive carefully before installation or operation.
		DANGER! Do not remove the front cover while the power is on or within 10 minutes after the power is turned off.

Figure 1-5 Schematic diagram of product parts (three-phase, 380V - 480V, MD500ET200G to MD500ET450G)

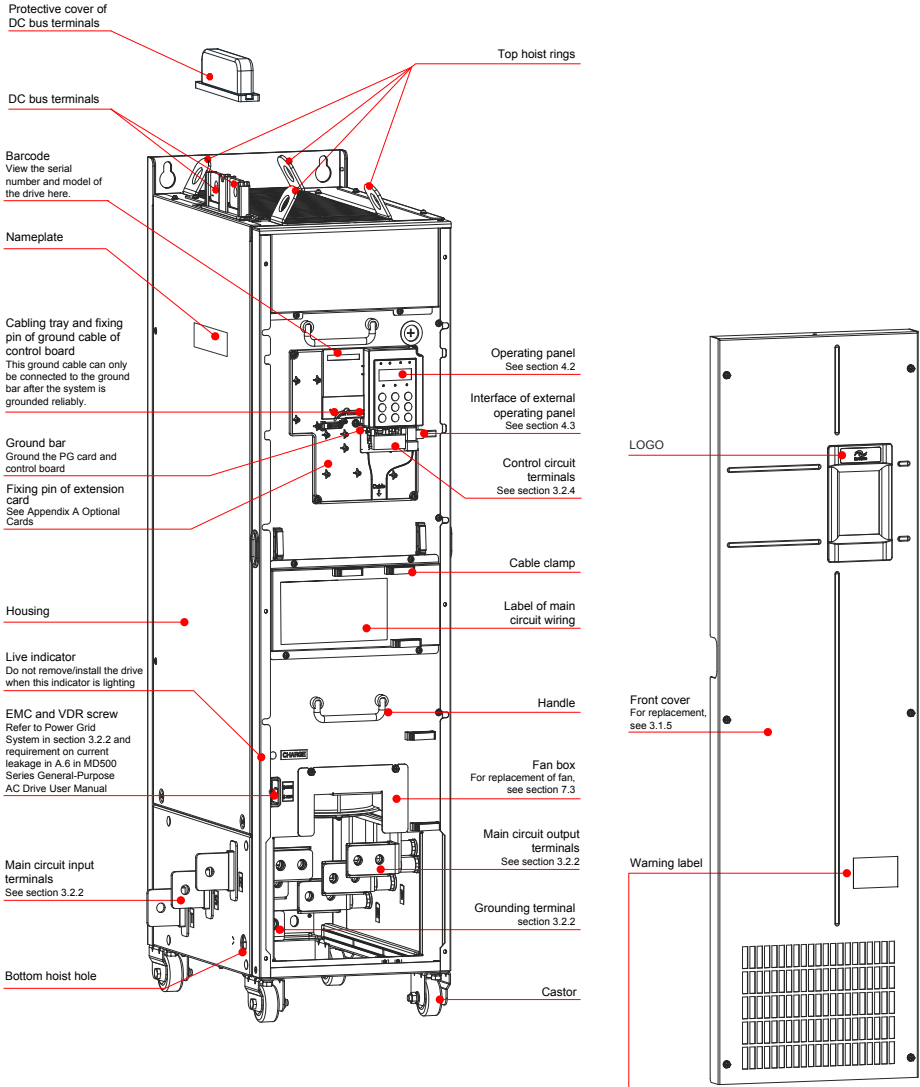
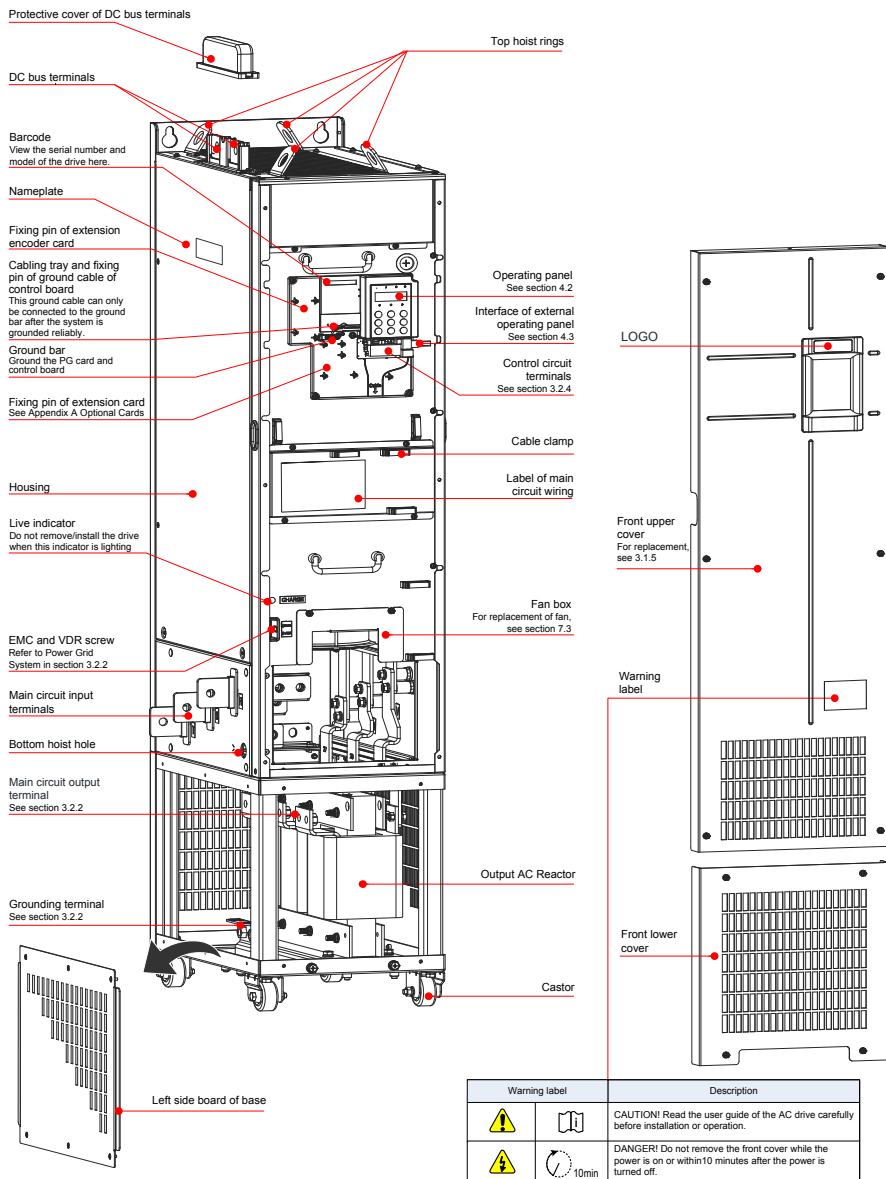

Figure 1-6 Schematic diagram of product parts (three-phase, 380V - 480V, MD500ET200G-L to MD500ET450G-L)

Warning label		Description
		CAUTION! Read the user guide of the AC drive carefully before installation or operation.
		DANGER! Do not remove the front cover while the power is on or within 10 minutes after the power is turned off.

1

2 System Connection

Safety Information



Danger

- ◆ Do not perform wiring when the power is turned on. Failure to comply may result in electric shock. Always keep breakers in OFF state.



Warning

- ◆ When installing the drive inside an enclosed cabinet or housing, use cooling fan or air conditioner to keep temperature below 50°C. Failure to comply may result in overheating or even a fire.



Caution

- ◆ Cover the top of the drive with a temporary cloth or paper during installation so as to prevent foreign matter such as metal shavings, oil and water from falling into the drive.
- ◆ If any foreign matter falls into the drive, the drive may have a fault.
- ◆ After the installation is completed, remove the temporary cloth or paper. If leaving the cloth or paper on the drive, the drive may have abnormal heating due to poor ventilation.
- ◆ Follow proper electrostatic discharge (ESD) procedures when operating the AC drive. Failure to comply will damage internal circuit of the drive.
- ◆ Operating the motor at low speed lowers the cooling effect and increases the motor temperature, which may result in damage to the motor. The motor heat emission conditions shall be improved.
- ◆ The motor speed range is subject to the lubrication method and manufacturer.
- ◆ If the required motor speed range differs from that of the motor manufacturer, please contact them for advice.
- ◆ If the torque characteristic is different with drive operation compared with operation from a commercial power supply, please check the load torque characteristic of the connected machine.
- ◆ Pay attention to the load torque characteristic when selecting the drive capacity. In addition, when there is a long distance between the motor and drive, use a cable with a large cross sectional area to connect between the motor and the drive to prevent motor torque reduction.
- ◆ If the rated current of the pole-changing motor is different from that of a standard motor, please check the maximum current of the motor and select an appropriate AC drive. Be sure to switch the pole after the motor stops.
- ◆ Do not lift the AC drive while the front cover is removed. Failure to comply may result in damage to PCB and terminal block.

2.1 MD500E System Connection Diagram

When using the drive to drive synchronous motor, a variety of electrical devices must be installed on both input and output sides to ensure system safety and stability. How to configure the AC drive (three-phase 380 V to 480 V, 0.4 kW and above) to operate with the peripheral devices is shown as below:

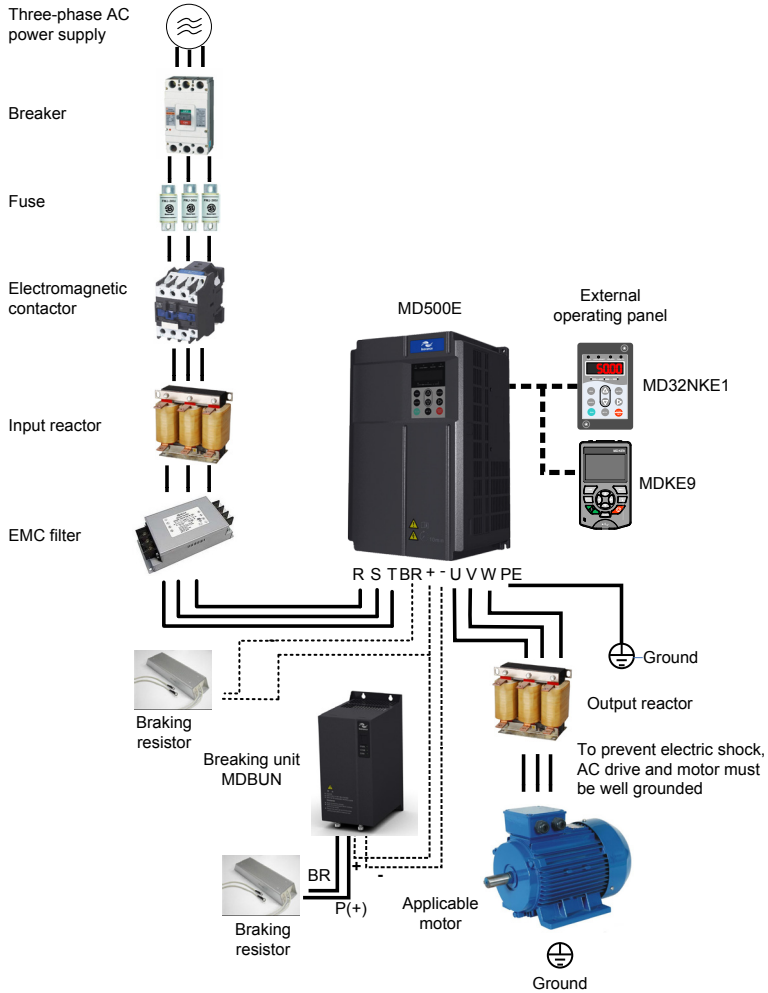

Figure 2-1 MD500E Series system composition

Note

- The above figure is just a schematic system connection diagram of MD500E Series AC drive. For peripherals and options, see "Chapter 8 Specifications and Model Selection".

2.2 MD500E Series System Composition

Table 2-1 Description of peripheral electrical devices in MD500E Series AC drive

Device	Mounting Location	Function Description
Breaker	Between power and AC drive input side	MCCB: Cut off power supply when overcurrent occurs on downstream devices
		Leakage breaker: Provide protection against potential leakage current during drive running to prevent electric shock and even a fire.
Fuse	Between power and AC drive input side	Provide protection in case of short circuit.
Contactora	Between breaker and AC drive input side	Switch ON/OFF the AC drive. Do not start/stop the AC drive frequently by switching contactor ON/OFF (time interval is at least one hour) nor use it to directly start the AC drive.
AC reactor	AC drive input side	Improve power factor of power input side.
		Eliminate higher harmonics of the input side effectively and prevent other devices from being damaged due to distortion of voltage waveform.
		Eliminate input current unbalance due to inter-phase unbalance.
EMC filter	AC drive input side	Reduce external conduction and radiation interference of the AC drive.
		Decrease conduction interference flowing from power supply to the AC drive and improve the anti-interference capacity of the AC drive.
DC reactor	Between EMC filter and braking resistor; It is standard configuration for the drive of 30 kW and above and optional for the drive of 18.5 to 22 kW.	Improve power factor of power input side.
		Improve efficiency and thermal stability of the AC drive.
		Eliminate impact of higher harmonics of the AC drive input side and reduce external conduction and radiation interference.
Braking resistor	GB-type model of 75 kW and below.	Use braking resistor for the GB-type model of 75 kW and below. Dissipate regenerative energy during motor deceleration.
Braking Unit	Full series except the GB-type model	Use braking unit MDBUN and MDBU of Inovance and recommended braking resistor for full series except the GB-type model. Dissipate regenerative energy during motor deceleration.
Output reactor	Between AC drive output side and the motor, close to the AC drive	Output side of the AC drive generally has much higher harmonics. When the motor is far from the AC drive, there is much distributed capacitance in the circuit and certain harmonics may cause resonance in the circuit, which will: (a) Degrade the motor insulation performance and damage the motor in long run. (b) Generate large leakage current and cause frequent AC drive protection trips. If distance between the AC drive and the motor is greater than 100 m, install an AC output reactor.
dv/dt reactor	AC drive output side, close to the AC drive	Optional. Protect motor insulation and reduce bearing current.
Output magnetic ring	AC drive output side, close to the AC drive	Reduce bearing current.
Motor	AC drive output side	Select an appropriate motor.

Note

- Do not install a capacitor or surge suppressor on output side of the AC drive. Otherwise, it may damage the AC drive.
- Inputs/Outputs (main circuit) of the AC drive contain harmonics, which may interfere with the communication device connected to the AC drive. Therefore, install an anti-interference filter to minimize interference.

3 Installation and Wiring

3.1 Installation

3.1.1 Installation environment

1. Ambient temperature: The AC drive service life is greatly influenced by the ambient temperature. Do not run the AC drive under a temperature exceeding the allowed temperature range (-10°C to 50°C).
2. Install the AC drive on the surface of a flame retardant object, and ensure there is sufficient space around the enclosure to allow for efficient heat dissipation. The AC drive generates great heat during working. Use screws to install the AC drive on the mounting support vertically.
3. Install the AC drive without strong vibration. Ensure the mounting location is not affected by levels of vibration that exceeds 0.6 G. Keep the drive away from punch machines.
4. Ensure the mounting location is away from direct sunlight, damp or water drops.
5. Ensure the mounting location is protected against corrosive, combustible or explosive gases and vapors.
6. Ensure the mounting location is free from oil and dust.

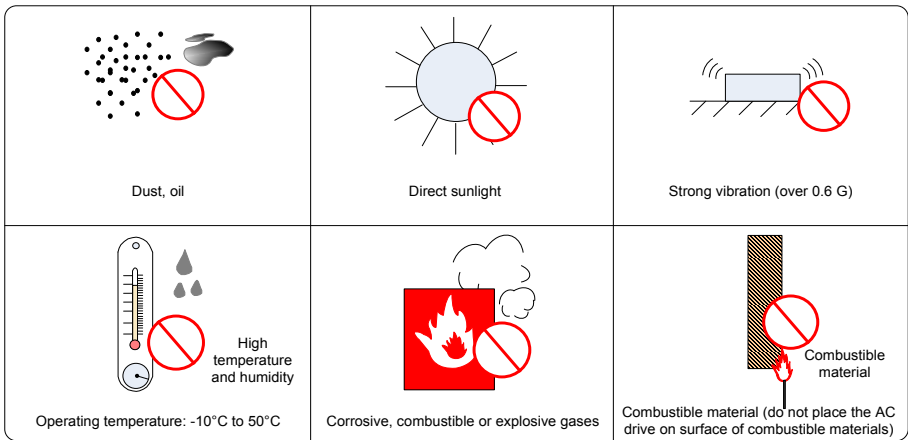

Figure 3-1 Installation environment requirements

7. The drive units must be installed in a fireproof cabinet with doors that provide effective electrical and mechanical protection. The installation must conform to local and regional laws and regulations, and to relevant IEC requirements.

3.1.2 Mounting Clearance and Orientation

1. Mounting Clearance

The mounting clearance varies with the power rating of the AC drive.

■ Mounting of a single drive

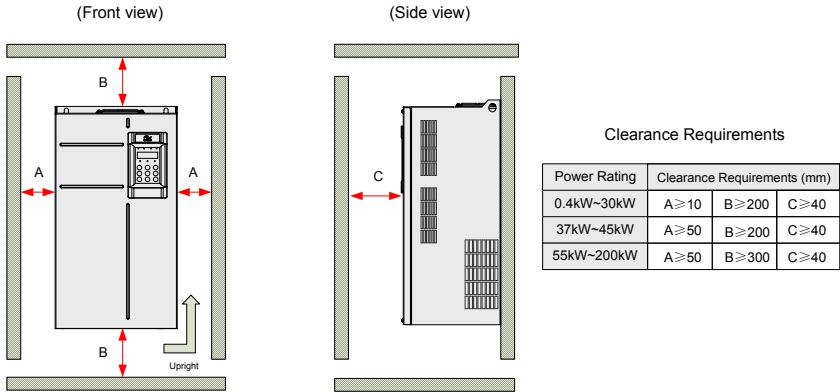

Figure 3-2 Mounting clearance of a single drive (MD500ET0.4GB to MD500ET160G)

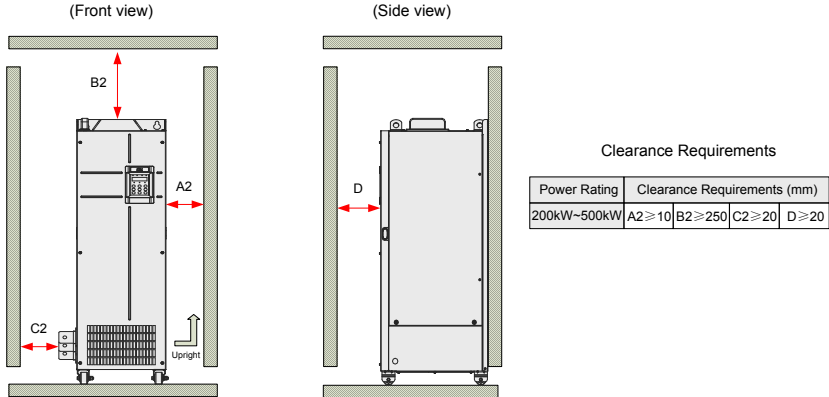

Figure 3-3 Mounting clearance of a single drive (MD500ET200G(-L) to MD500ET450G(-L))

■ Clearance for multi-drive installation

The AC drive is designed with the cooling air flow direction from bottom to top. When installing several AC drives within a cabinet, it is necessary to line up the tops of the drives.

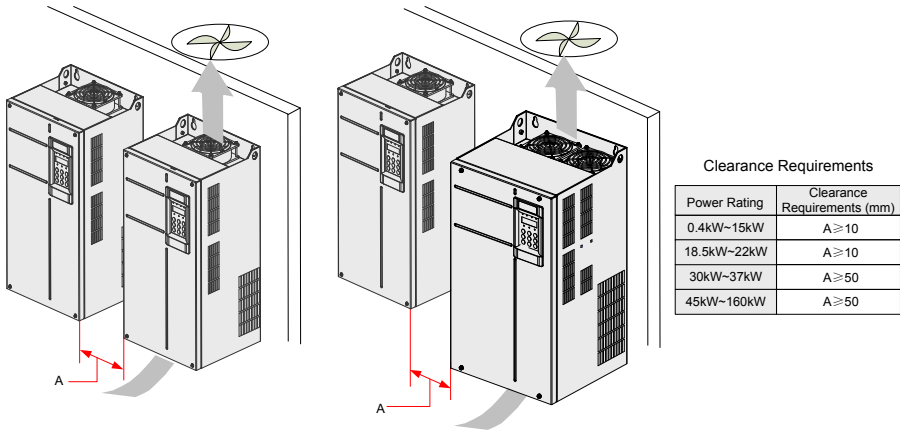

Figure 3-4 Clearance for multi-drive installation (MD500ET0.4GB to MD500ET160G)

Note

- MD500ET200G(-L) to MD500ET450G(-L) support only single-drive installation. For multi-drive installation, contact the manufacturer.

■ Installation of an air guide plate

Where an AC drive is required to be mounted directly above another AC drive, it is recommended to install an Air Guide Plate to divert exhaust cooling air of the bottom unit away from the top unit.

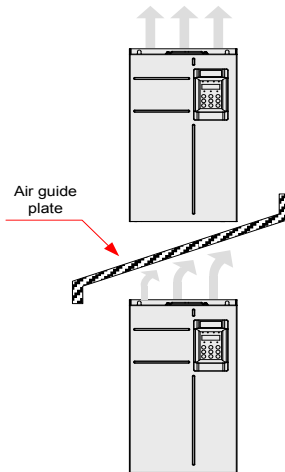

Figure 3-5 Installation of an air guide plate

Note

- MD500ET200G(-L) to MD500ET450G(-L) do not support this mode.

2. Mounting Orientation

Always mount the AC drive in an upright position.

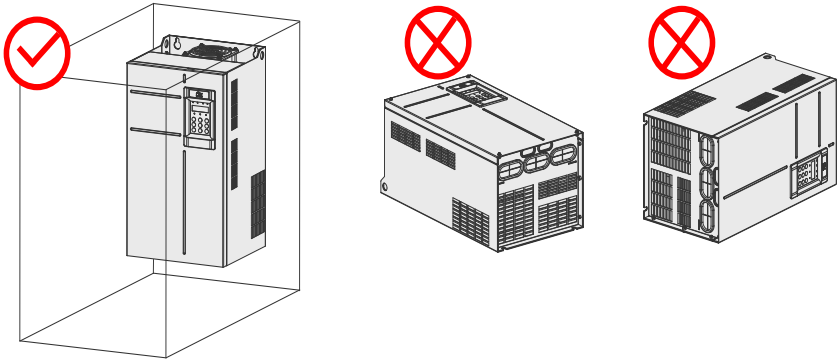



Figure 3-6 Mounting orientation diagram

3.1.3 Installation of MD500ET0.4GB to MD500ET160G

Drives MD500ET0.4GB to MD500ET160G support backplate mounting and through-hole mounting. Follow the following guidance for specific model and application scenarios.

 <p>Caution</p>	<ul style="list-style-type: none"> ◆ Refer to Figure 3-2 for mounting clearance requirements. Ensure there is sufficient space allowed for efficient heat dissipation of the drive and the other devices in the cabinet. ◆ Mount the AC drive in an upright position for efficient heat dissipation. When installing several AC drives within a cabinet, line up the tops of the drives. Where an AC drive is required to be mounted directly above another AC drive, install an Air Guide Plate, as shown in Figure 3-5. ◆ The mounting bracket must be flame retardant. ◆ In a place with metallic powders, mount the AC drive in a fully closed cabinet with sufficient space. It is recommended to mount the heat sink outside the cabinet.
---	---

1. Backplate Mounting

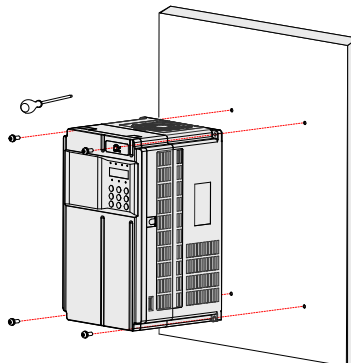

Figure 3-7 Backplate mounting of MD500ET0.4GB to MD500ET37G(B)

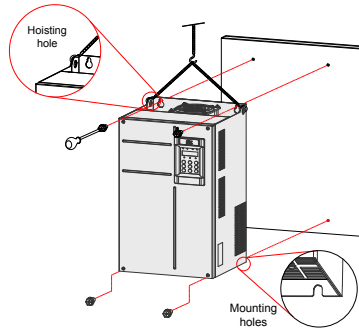

Figure 3-8 Backplate mounting of MD500ET45G(B) to MD500ET160G



◆ In this mode, do not just secure two screws on the top of the drive; otherwise, the drive may fall off or be damaged due to unbalanced effect on the fixed part during long-time running.

2. Through hole mounting

3

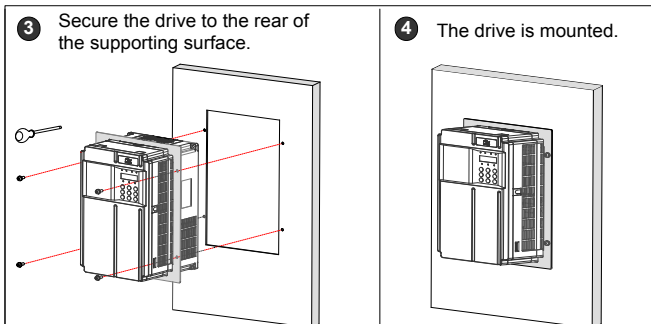
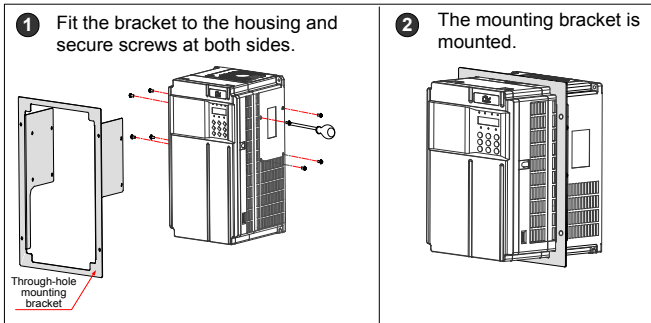

Figure 3-9 Through hole mounting of MD500ET0.4GB to MD500ET37G(B)

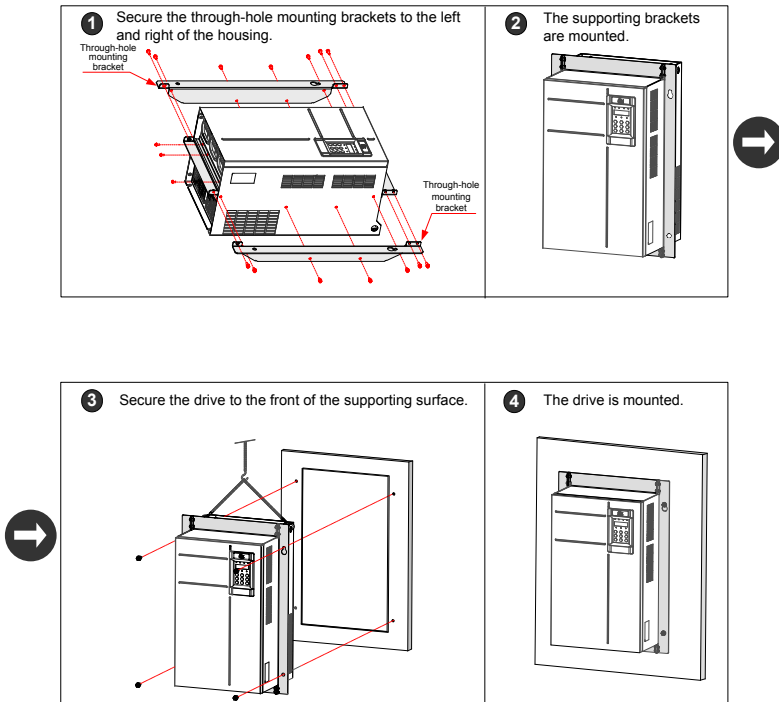

Figure 3-10 Through hole mounting of MD500ET45G(B) to MD500ET160G

3. Through Hole Mounting Model

Table 3-1 Through hole mounting model

Through Hole Mounting Model	Applicable AC Drive Model	Bracket Dimensions
MD500-AZJ-A1T1	MD500ET0.4GB	For details about appearance and dimensions of through hole mounting brackets, refer to Section 8.2.
	MD500ET0.7GB	
	MD500ET1.1GB	
	MD500ET1.5GB	
	MD500ET2.2GB	
	MD500ET3.0GB	
MD500-AZJ-A1T2	MD500ET3.7GB	
	MD500ET5.5GB	
MD500-AZJ-A1T3	MD500ET7.5GB	
	MD500ET11GB	
MD500-AZJ-A1T4	MD500ET15GB	
MD500-AZJ-A1T5	MD500ET18.5G(B)(-T)	
	MD500ET22G(B)(-T)	
MD500-AZJ-A1T6	MD500ET30G(B)	
	MD500ET37G(B)	
MD500-AZJ-A1T7	MD500ET45G(B)	
	MD500ET55G(B)	
MD500-AZJ-A1T8	MD500ET75G(B)	
	MD500ET90G	
	MD500ET110G	
MD500-AZJ-A1T9	MD500ET132G	
	MD500ET160G	

3.1.4 Mounting in Cabinet

1. Ventilation

Only one drive of models MD500ET200G to MD500ET450G can be mounted in a cabinet. Ventilation space must be considered when drives of MD500ET200G to MD500ET450G are mounted in the cabinet. Follow the following guidance for specific model and application scenarios.

■ Direct discharging cabinet (without fan on the top)

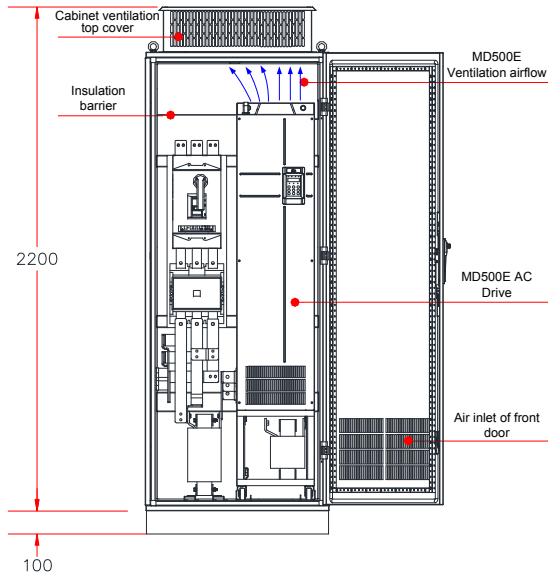

Figure 3-11 Direct discharging cabinet

3

Table 3-2 Specification of direct discharging cabinet

AC Drive Model	Quantity of Fans	Total Air Volume (CFM)	Effective Area of Cabinet Top Air Inlet (mm ²)	Effective Area of Cabinet Top Air Outlet (mm ²)
MD500ET132G	2	541	31809	50894
MD500ET160G	2	620	31809	50894
MD500ET200G(-L)	2	586	31809	50894
MD500ET220G (-L)	2	722	31809	50894
MD500ET250G (-L)	3	789	47713	76341
MD500ET280G (-L)	3	882	47713	76341
MD500ET315G (-L)	3	644	47713	76341
MD500ET355G (-L)	3	796	47713	76341
MD500ET400G (-L)	3	796	47713	76341
MD500ET450G (-L)	3	796	47713	76341

Note

- CFM = 0.0283 m³/min
- Effective area means through-hole area.

■ Cabinet with fan on the top

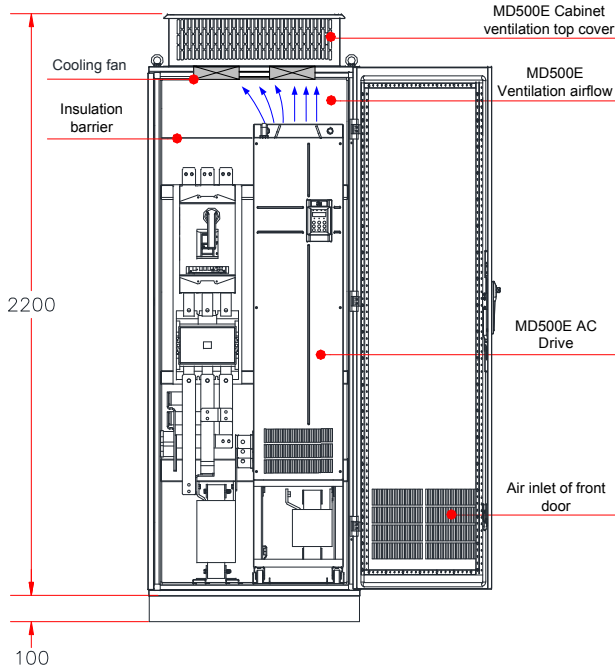

Figure 3-12 Cabinet with fan on the top

Table 3-3 Specification of cabinet with fan on the top

AC Drive Model	Quantity of Fans	Total Air Volume (CFM)	Effective Area of Cabinet Top Air Inlet (mm ²)	Max. Air Volume Required by the Top Fan (CFM)	Effective Area of Cabinet Top Air Outlet (mm ²)
MD500ET132G	2	541	31809	649	$S = 0.942 \times N \times (D_{out2} - DHUB2)$ In the preceding formula, N means the quantity of top fans, D _{out} means diameter of the top fan, and DHUB means diameter of the top fan center HUB.
MD500ET160G	2	620	31809	744	
MD500ET200G (-L)	2	586	31809	703	
MD500ET220G (-L)	2	722	31809	866	
MD500ET250G (-L)	3	789	47713	947	
MD500ET280G (-L)	3	882	47713	1058	
MD500ET315G (-L)	3	644	47713	773	
MD500ET355G (-L)	3	796	47713	955	
MD500ET400G (-L)	3	796	47713	955	
MD500ET450G (-L)	3	796	47713	955	

Note

- CFM = 0.0283 m³/min
- Effective area means through-hole area.

As shown in Figure 3-13, an insulation barrier is required to prevent hot air circulating inside the cabinet.

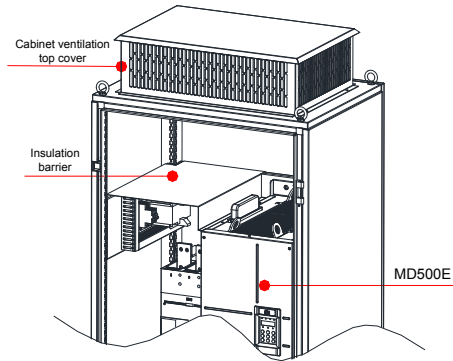

Figure 3-13 Insulation barrier in the cabinet

2. Precautions

A Nine-folding AL cabinet (PS cabinet) is recommended for installation of the drive. Before installing the AC drive, check whether fixing beams with fixing holes are mounted to the cabinet back correctly. Then prepare bottom mounting bracket and guide rail (for mounting position and dimensions, see Section 8.2.5). Reserve sufficient space at the bottom of the cabinet for connecting the side entry terminal.

You can push the AC drive into the cabinet or pull it out of the cabinet after moving the drive onto the guide rail. Make sure to align the castors to the guide rail and arrange two persons for drive push-in and pull-out to ensure safety.



Caution

- ◆ Refer to Figure 3-3 for mounting clearance requirements. Ensure there is sufficient space allowing for efficient heat dissipation of the drive and the other devices in the cabinet, as shown in Figure 3-11 and Figure 3-12.
- ◆ Use an extended rod sleeve to operate on the copper terminal of power lines in the main circuit
- ◆ Make sure to align the castors to the guide rail and arrange two persons for drive push-in and pull-out to ensure safety, as shown in Figure 3-20 and Figure 3-21.
- ◆ Refer to Figure 3-14 for cabinet layout before mounting the drive in cabinet. The cabinet dimension is 2200 x 800 x 600 mm. The height 2200 mm includes the 200 mm cabinet ventilation top cover but does not include the 100 mm cabinet base. Insulation barrier must be installed at the top of the cabinet to avoid circulation of ventilation airflow within the cabinet. In addition, ensure there are air inlet openings at the bottom of the cabinet.
- ◆ For dimensions of the mounting bracket (delivered with the drive), refer to Section 8.2. The guide rail must have enough strength and stiffness.
- ◆ After push-in, remove the baffle on the top of the drive to prevent overheating because ventilation air cannot flow out.

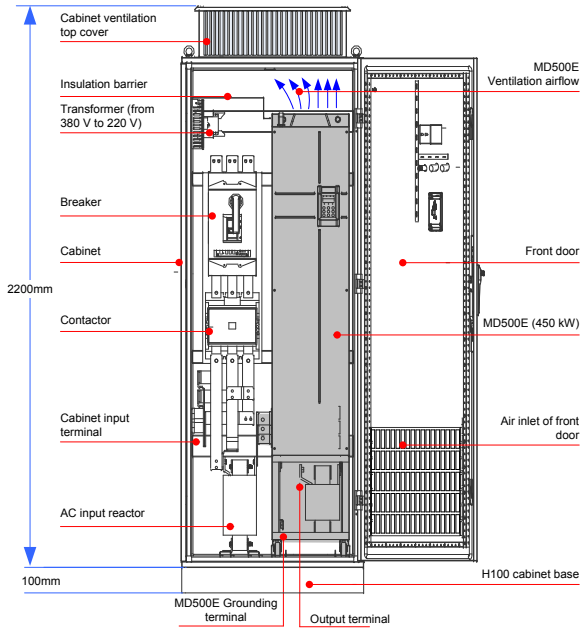

Figure 3-14 Recommended cabinet layout

3. Steps of installing the AC drive in cabinet

3

Step	Description
1	Install the fixing beam in the nine-folding AL cabinet, as shown in Figure 3-15.
2	Secure the bottom mounting bracket, as shown in Figure 3-17.
3	Assemble the guide rail (optional) and connect the guide rail to cabinet.
4	Remove the cover from the drive (refer to Section 3.1.5). Then the handle is exposed.
5	Arrange two persons to align castors of the drive to the guide rail and push the drive into the cabinet slowly, as shown in Figure 3-20 and Figure 3-21. Use soft strap in the process of push-in and push-out to prevent turnover.
6	Remove the soft strap. There are two mounting holes at the back of the drive. Secure the mounting holes at the top and bottom parts at the back of the drive to secure the drive to the fixing team, as shown in Figure 3-22.
7	Check installation of the drive is secure and remove the guide rail.

- Install the fixing beam and reserve mounting holes
- A Nine-folding AL cabinet (PS cabinet) is recommended for installation of the drive. The cross section of the nine-folding AL cabinet is shown in Figure 3-15.
- When the drive of MD500ET200G(-L) to MD500ET450G(-L) is mounted in the nine-folding AL cabinet of 600 mm deep, the fixing beam must fold inwards, as shown in Figure 3-16. When the drive is mounted in the cabinet of 800 mm deep, folding inwards is not required.

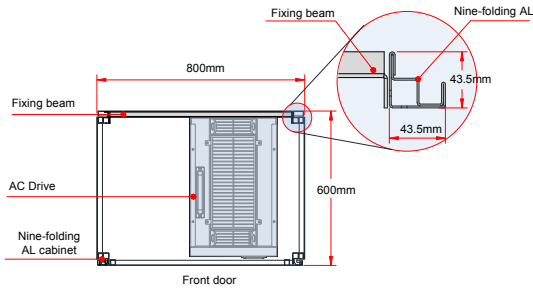

Figure 3-15 Top view of MD500ET200G(-L) to MD500ET450G(-L)

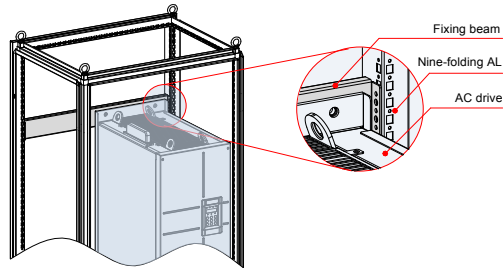

Figure 3-16 3D view of MD500ET200G(-L) to MD500ET450G(-L)

Note

- If the cabinet has a front door and a back door, the cabinet of 600 mm deep is too small to accommodate the drive of MD500ET200G(-L) to MD500ET450G(-L). In this case, the cabinet of 800 mm deep is recommended.

3

- Fix the bottom mounting bracket
- Use six M5 tapping screws to fix the mounting bracket on the nine-folding AL cabinet according to the following figure (the mounting bracket drawing is shown in 8.2.5).
- If a non-nine-folding AL cabinet is used, drill mounting holes for the mounting bracket on site.

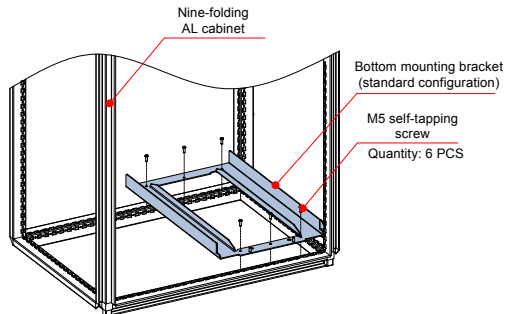

Figure 3-17 Installing the bottom mounting bracket

3 Installation and Wiring

■ Assemble the guide rail (model: MD500-AZJ-A3T10, optional)

As shown in Figure A, assemble the guide rail of correct model. The assembled guide rail is shown in Figure B. As shown in Figure C, align the two holes at the front of the guide rail with the studs of the mounting bracket, and fix them with two M6 nuts.

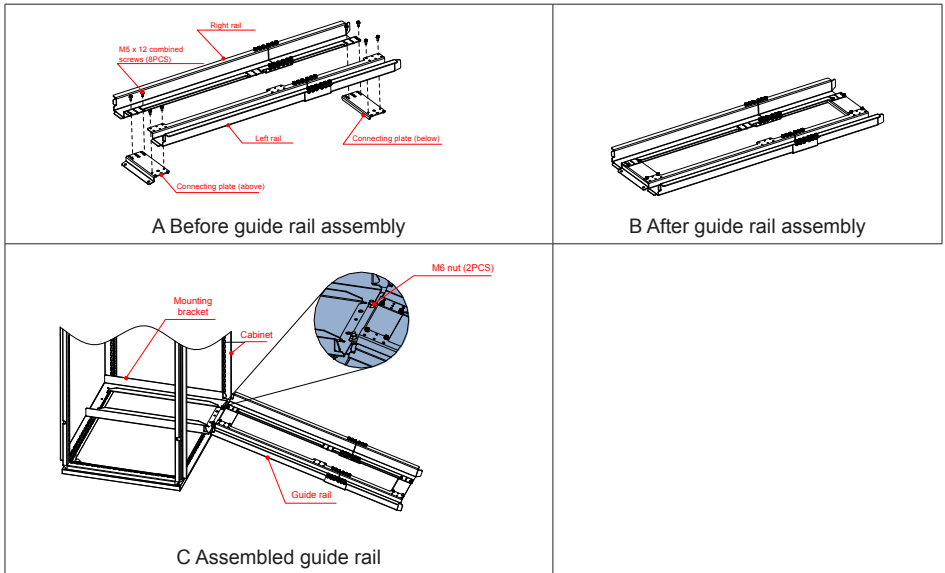

Figure 3-18 Assembling the guide rail in the cabinet

3

Note

- Carefully read 19010353 MD500-AZJ-A3T10 Guide Rail Assembly Instructions before assembling the guide rail.

■ Install the AC drive in the cabinet

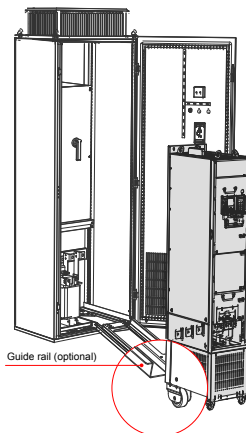

Figure 3-19 Align castors of the drive to the guide rail

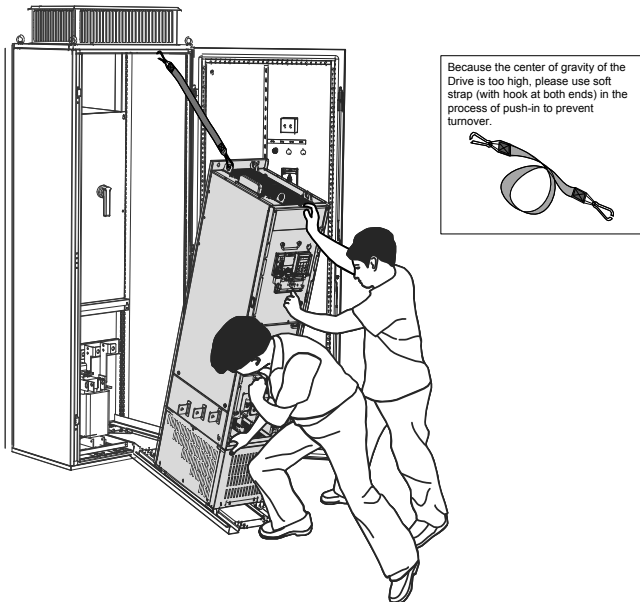

Figure 3-20 Push the drive into the cabinet

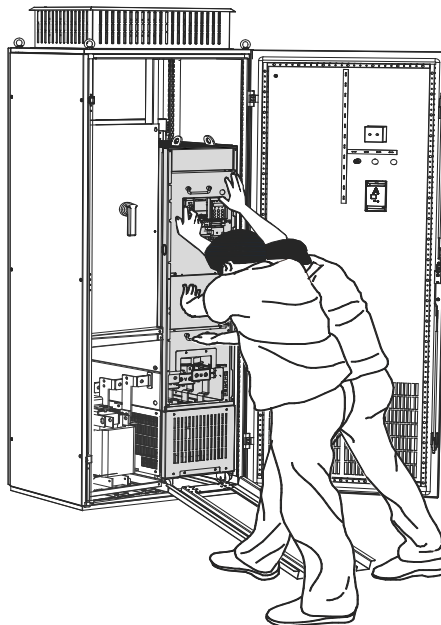

Figure 3-21 Push-in completed

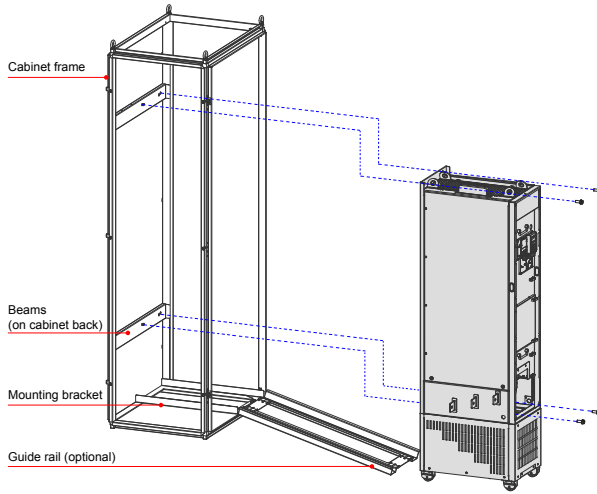
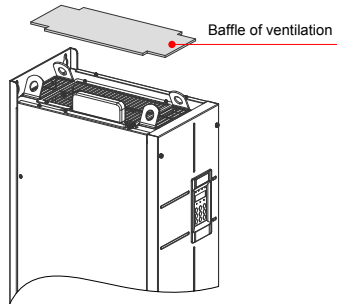

Figure 3-22 Fix the AC drive to the beams on the back of the cabinet through the four mounting holes on the back of the drive

4. Precautions

- Remove the AC drive from the cabinet according to above steps in reverse order.
- Ensure the four mounting holes on the back of the drive are connected to the beams securely.
- After push-in is completed, remove the baffle on the top of the drive. The baffle is used to prevent foreign objects such as screws from falling into the ventilation when the drive is mounted in the cabinet.



- Please use top hoist rings to move or hoist the drive. If it is necessary to place the drive in a horizontal position, use the top hoist ring and bottom hoist hole when you hoist the drive again. Ensure the DC bus terminals suffer no stress.

3

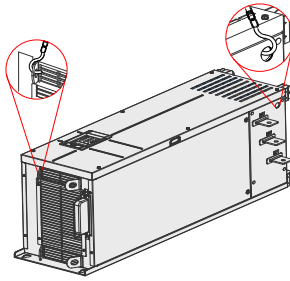

- If it is necessary to place the drive in an upright position, prevent a stress on both sides of the drive and prevent placing the drive on an inclined floor because the drive weighs almost 200 kg. If inclination exceeds 5°, the drive may turn over.

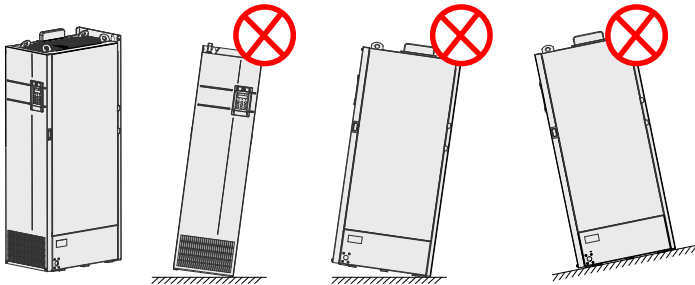

3.1.5 Remove and Refit the Cover

You need to remove the cover of the AC drive for wiring of the main circuits and control circuits.



Danger

- ◆ Ensure the drive power-off time exceeds 10 minutes before removing the cover.
- ◆ Be careful when removing the front cover. A falling cover may cause personal injury.

3

1. Remove and Refit of the Cover of Drives of MD500ET0.4GB to MD500ET37G(B)

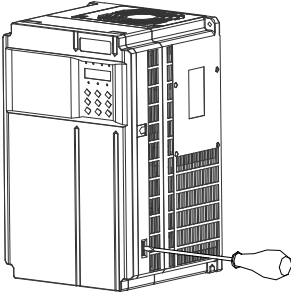
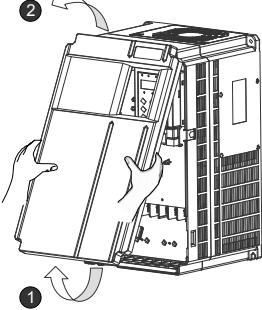
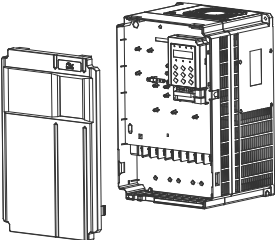
Removal		
<p>Pinch inwards on the latch on both sides of the cover to release the cover</p> 	<p>① Hold the lower part of the cover, ② Lift the cover.</p> 	<p>The cover is removed.</p> 

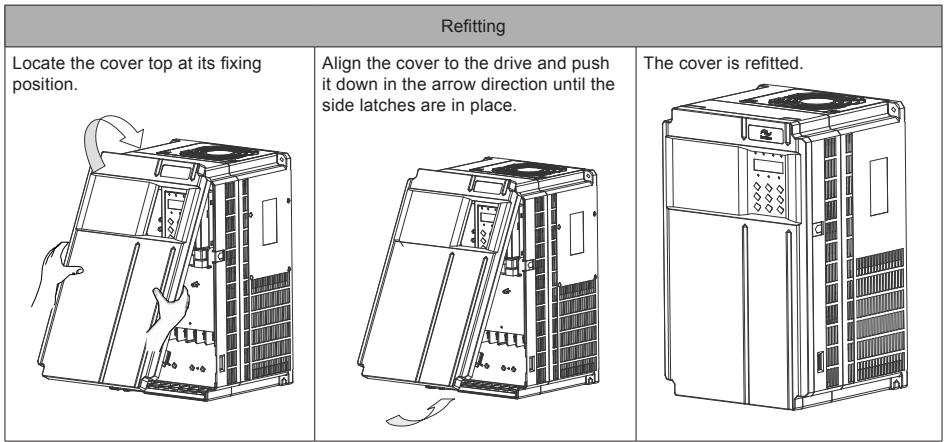

Figure 3-23 Remove and refit the cover of drives of MD500ET0.4GB to MD500ET37G(B)

2. Remove and Refit of the Cover of Drives of MD500ET45G(B) to MD500ET160G

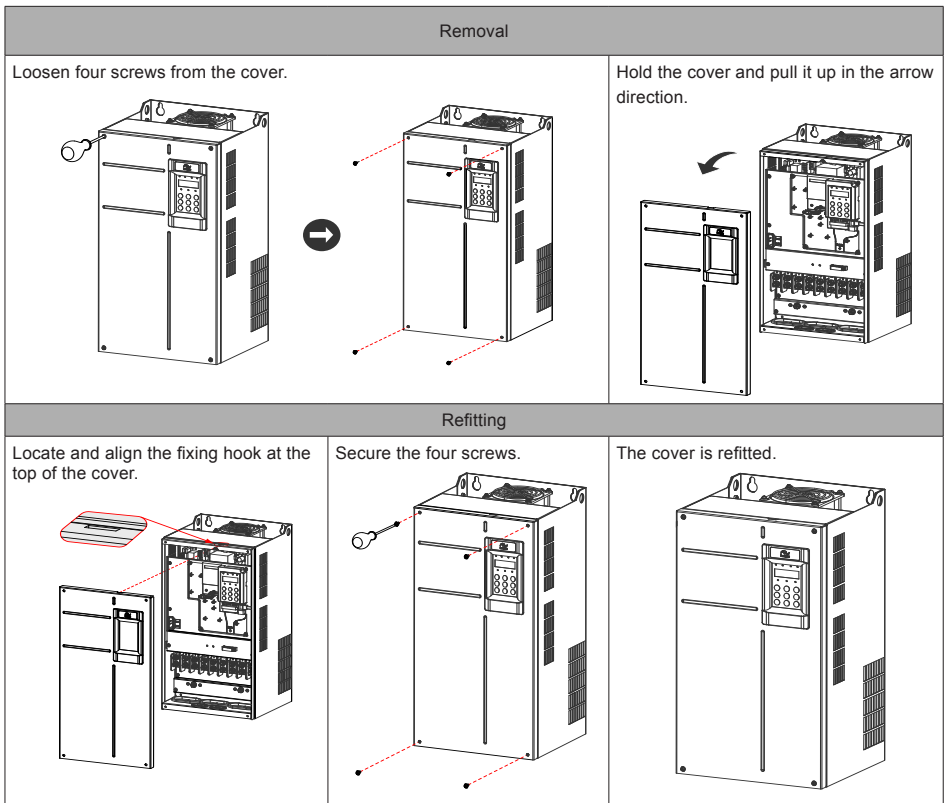

Figure 3-24 Remove and refit the cover of drives of MD500ET45G(B) to MD500ET160G

3. Remove and Refit of the Cover of Drives MD500ET200G(-L) to MD500ET450G(-L)

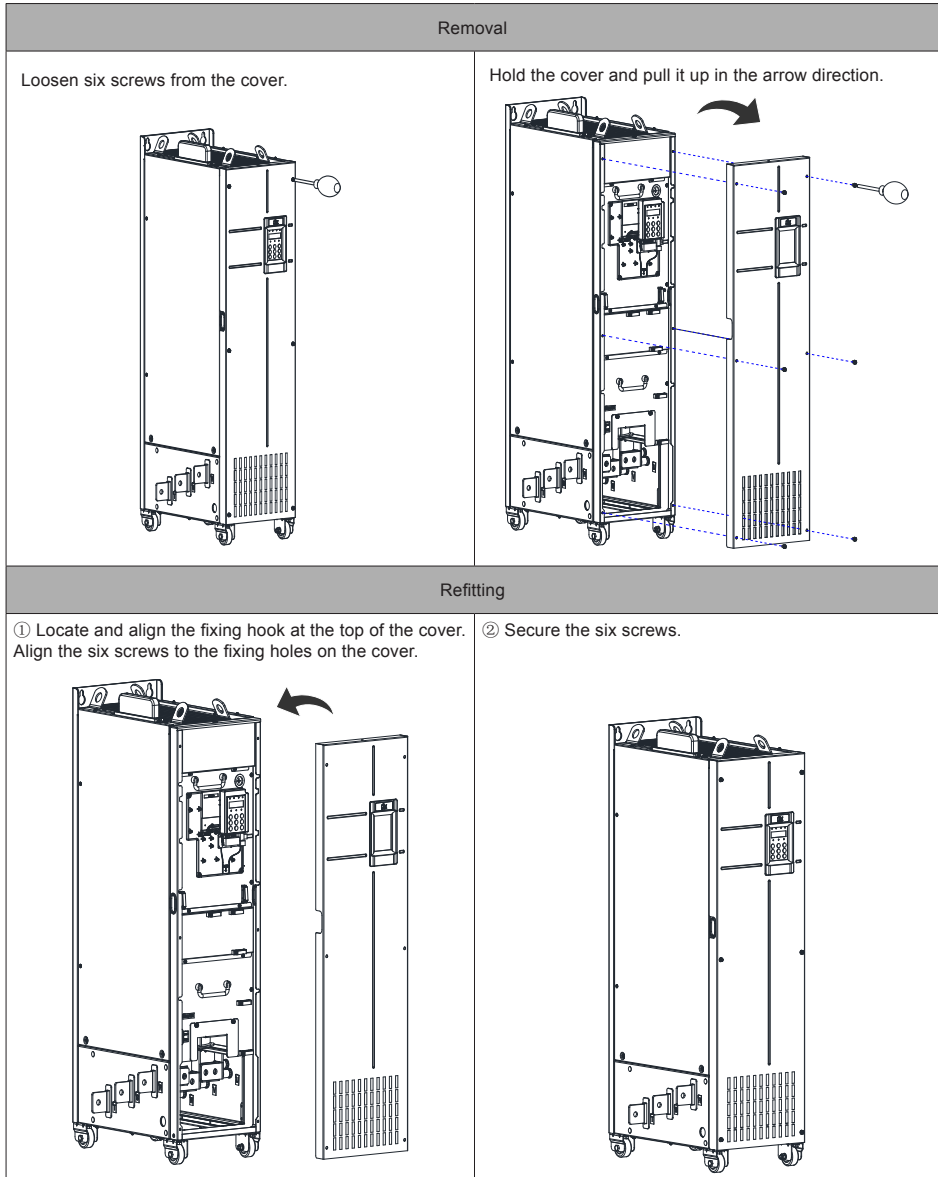
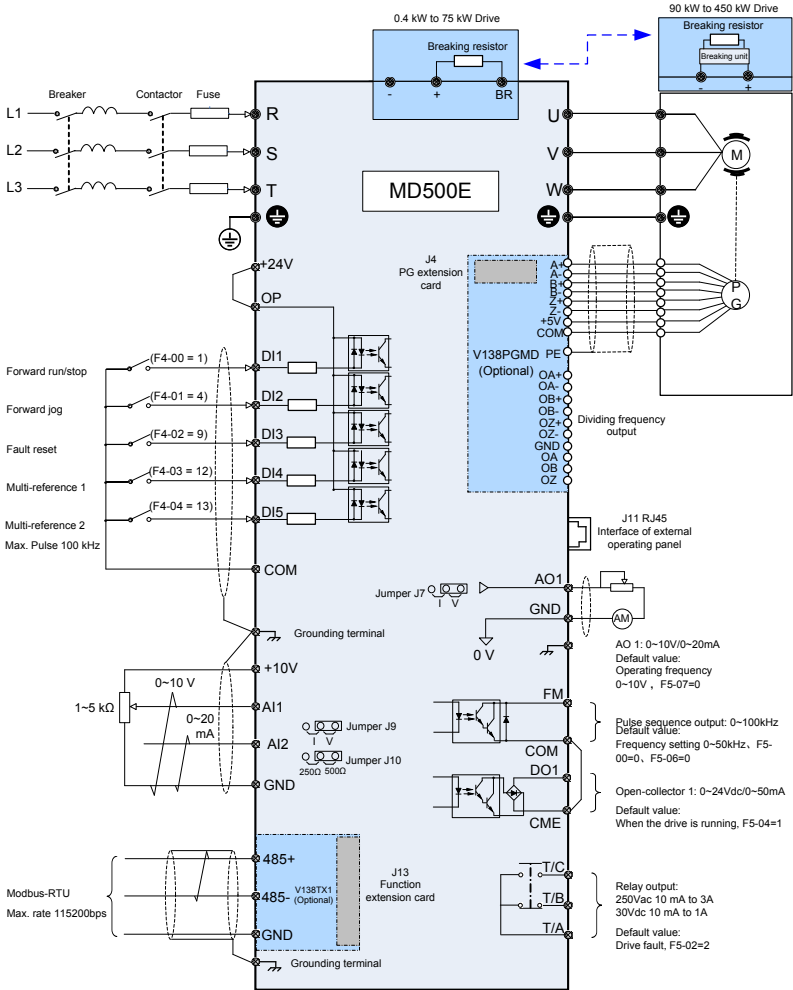

Figure 3-25 Remove and refit of the cover of drives MD500ET200G(-L) to MD500ET450G(-L)

3.2 Wiring

3.2.1 Standard Wiring Diagram

As shown in the following figure, the wiring part at the 0.4 kW~75 kW marked by double-headed arrow in 0.4 to 75 kW and 90 to 450 kW models is different.



Note: —shield; —twisted pair

Figure 3-26 Wiring diagram of a typical three-phase 380 to 480 V drive

3.2.2 Functions of Main Circuit Terminals and Precautions

1. Main Circuit Terminals

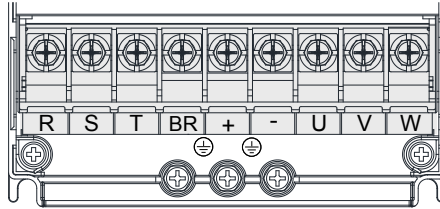

Figure 3-27 Terminal arrangement in MD500ET0.4GB to MD500ET15GB

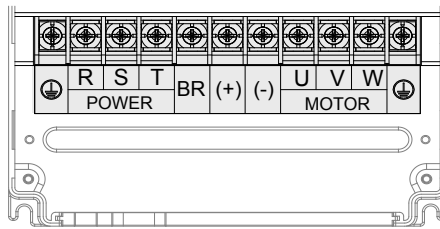

Figure 3-28 Terminal arrangement in MD500ET18.5G(B) to MD500ET160G

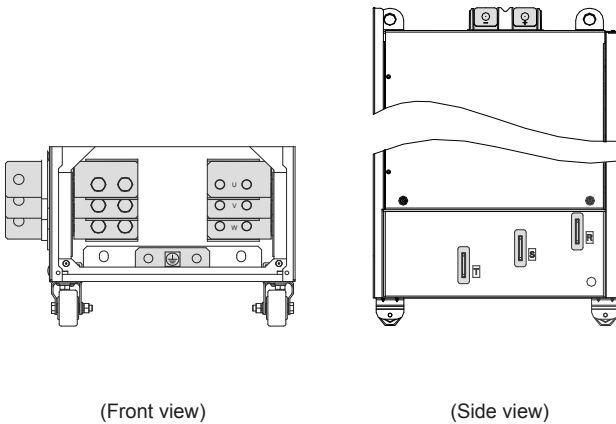



Figure 3-29 Terminal arrangement in MD500ET200G(-L) to MD500ET450G(-L)

Table 3-4 Description of the drive terminals

Terminal	Terminal Name	Function Description
R, S, T	Three-phase supply input	Connected to three-phase power supply.
(+), (-)	DC bus terminals	Connected to external braking unit (MDBUN) with AC drive units of 90 kW and above.
(+), BR	Braking resistor connection	Connected to external braking resistor for AC drive units of 75 kW and below.
U, V, W	AC drive outputs	Connected to a three-phase motor.
	Ground (PE)	Grounding connection.

2. Main Circuit Cable Selection

Inovance recommends symmetrical shielded cables as the main circuit cable, which can reduce electromagnetic radiation of the entire conductive system compared with four-conductor cables.

- Recommended power cable: symmetrical shielded cable

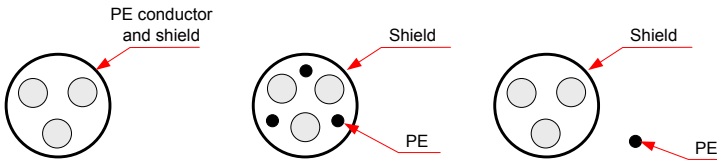

Figure 3-30 Recommended power cable

- Non-recommended power cable

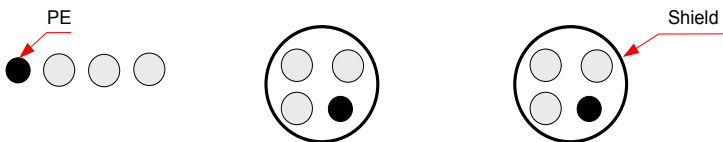

Figure 3-31 Non-recommended power cable

3. Power input R, S, T

- There are no phase sequence requirements for three-phase cable connections.
- Specification and installation of all external power cables must comply with local safety regulations and relevant IEC standards.
- Install filter close to power input side of the AC drive with a cable shorter than 30 cm. Connect the ground terminal of the filter and the ground terminal of the drive together to the cabinet main grounding terminal.

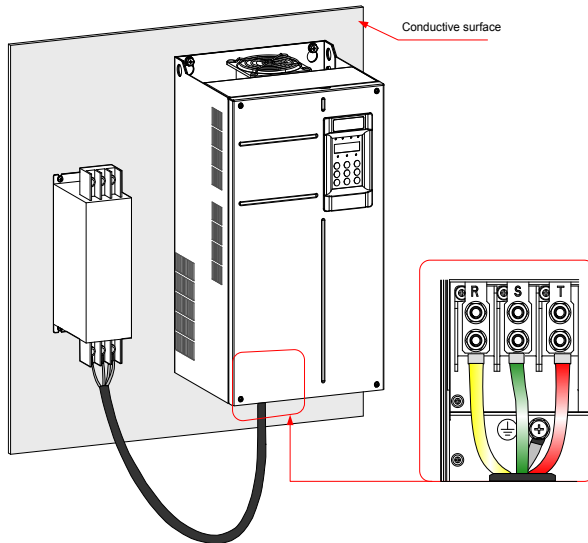

Figure 3-32 Mount the filter

4. DC bus terminals (+) and (-)

- DC bus terminals, labeled (+) and (-), are terminals that carry a residual voltage for a period after the drive has been switched off.
- To avoid risk of equipment damage or fire, when you select an external braking unit for use with an AC drive of 90 kW and above, DO NOT reverse the poles (+) and (-).
- Use a cable not exceeding 10 m to connect DC bus terminals to the external MDBUN braking unit. Use twisted pair wires or close pair wires for this connection.
- Fire risk! Do not connect the braking resistor directly to the DC bus.

5. Braking Resistors (+) and BR

- Braking resistor terminals (+) and PB are only for the drive units up to 75 kW that are fitted with an internal braking unit.
- To avoid risk of equipment damage, use a cable not exceeding 5 m to connect an external braking resistor. Failure to comply may cause damage to the drive.
- To avoid risk of ignition due to overheating of the braking resistor, do not place anything combustible around the braking resistor.
- Set F6-15 (Braking use ratio) and F9-08 (Braking unit action initial voltage) correctly according to load after connecting the braking resistor to the drive of up to 75 kW that is fitted with an internal braking unit.

6. AC Drive Outputs UVW

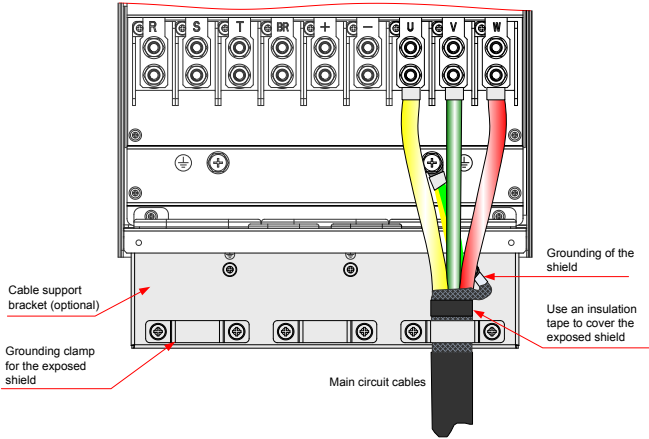

Figure 3-33 Drain wire

The cable support bracket in Figure 3-33 is an optional accessory. You need to buy a bracket applicable to MD500ET160G and previous models. Installation of the bracket is shown below.

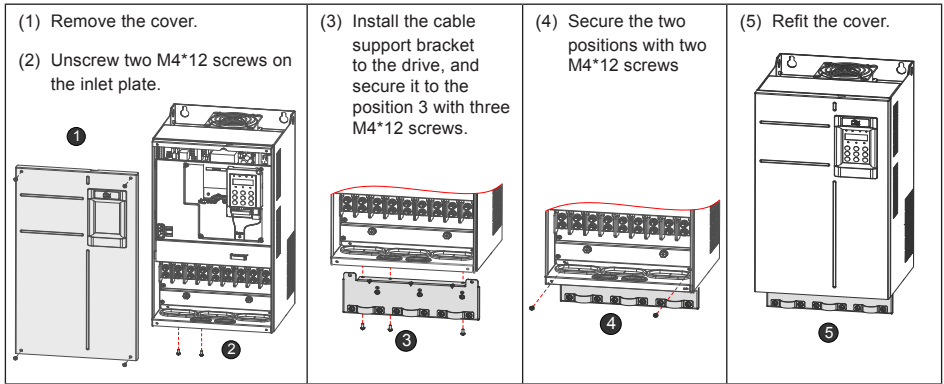

Figure 3-34 Installation of cable support bracket

Table 3-5 Cable Support Bracket Models

Cable Support Bracket Model	Applicable Drive Model
MD500-AZJ-A2T1	MD500ET0.4GB
	MD500ET0.7GB
	MD500ET1.1GB
	MD500ET1.5GB
	MD500ET2.2GB
	MD500ET3.0GB
MD500-AZJ-A2T2	MD500ET3.7GB
	MD500ET5.5GB
MD500-AZJ-A2T3	MD500ET7.5GB
	MD500ET11GB
MD500-AZJ-A2T4	MD500ET15GB
MD500-AZJ-A2T5	MD500ET18.5G(B)(-T)
	MD500ET22G(B)(-T)
MD500-AZJ-A2T6	MD500ET30G(B)
	MD500ET37G(B)
MD500-AZJ-A2T7	MD500ET45G(B)
	MD500ET55G(B)
MD500-AZJ-A2T8	MD500ET75G(B)
	MD500ET90G
	MD500ET110G
MD500-AZJ-A2T9	MD500ET132G
	MD500ET160G

- Cable specification and installation of all cables connected to the drive output U, V, W must comply with local safety regulations and relevant IEC standards.
- Refer to Table 8-7 Peripherals and options for recommendations and copper conductor dimensions of cables in the main circuit.
- To avoid risk of equipment damage or operating faults, do not connect a capacitor or surge absorber to the output side of the AC drive.
- Long motor cables can contribute to electrical resonance caused by distributed capacitance and inductance. In some cases, this might cause equipment damage in the drive, in motor or in cables. To avoid these problems, install an AC output reactor close to the drive if cable is longer than 100 m.
- The shielding cables are recommended for the motor. The shielding layer must be wound onto the cable support bracket. The drain wire must be grounded to the grounding (PE) terminal.
- Ensure the drain wire of the motor cable shield is as short as possible and its width must be no less than 1/5 of its length.

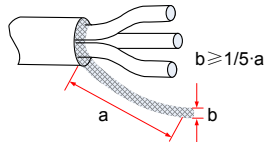

Figure 3-35 Drain wire of motor cable shield

7. Grounding (PE) Connection

- For personal safety and reliability of the equipment, it is important to connect ground (PE) terminal to an effective electrical ground. Resistance value of the ground cable must be less than 10 Ω.
- Do not connect the grounding (PE) terminal
- Refer to Table 8-7 Peripherals and options for dimensions of the grounding connection.
- Use proper grounding cable with yellow/green insulation for the protective grounding conductor.
- Ground the shield.
- It is recommended that the drive be installed on a metal mounting surface.
- Install the filter and the drive on the same mounting surface and ensure filtering effect.

8. Main Circuit Cable Protection

- Add heat shrink tube to the cable lug cooper tube and cable core part of the main circuit cable and ensure the heat shrink tube completely covers the cable conductor part, as shown in the following figure.

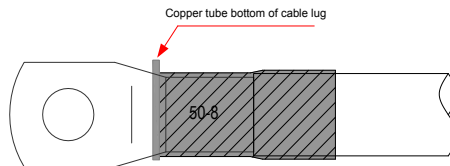

Figure 3-36 Heat shrink tube of the cable conductor part

9. Power Input Protection

- Install protection devices (a fuse and a MCCB) at power input to the drive. The protection devices must provide protection on overcurrent and short-circuit, and be able to completely isolate the drive from the electrical power input.
- Cables and protection device on power input must be suitably rated for the power and voltage class of the drive under normal conditions, and under possible fault conditions such as system overload and short-circuit on the power input. Use recommended values in Table 8-7 Peripherals and Options.

10. Power Grid System

- The drive is applicable to system with neutral point grounded. If the drive is used in an IT power system with an ungrounded power system or a high resistance grounded [over 30 ohms] power system, it is necessary to remove both VDR and EMC screws 1 and 2 as shown in Figure 3-37. Do not install a filter. Failure to comply may result in personal injury or damage to the drive.
- If a residual-current device (RCD) is used and it trips at start, remove the EMC screw 2 as shown in Figure 3-37.

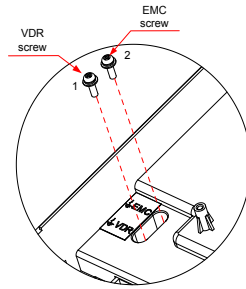

Figure 3-37 VDR screw and EMC screw

3.2.3 Main Circuit Terminal Arrangement and Dimensions

Note

- Drives of MD500ET200G to MD500ET450G have a side entry terminal by default. The side entry terminal can be removed if necessary.
- Data and models recommended in this section are for reference only. The user selected cable diameter must not be larger than the terminal width in the following figures.
- Selection of IEC cables is based on:
 - Standards EN 60204-1 and IEC 60364-5-52
 - PVC insulation
 - 40°C ambient temperature and 70°C surface temperature
 - Symmetrical cable with copper mesh shield
- A maximum of 9 cables are allowed in a cable tray.

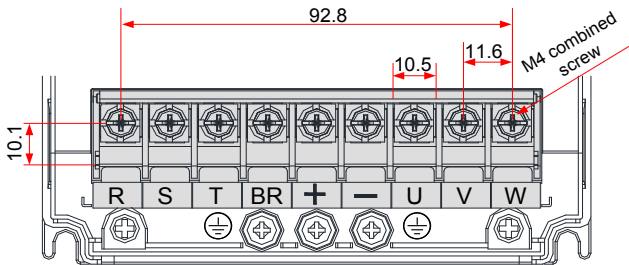

Figure 3-38 Terminal dimensions of MD500ET0.4GB to MD500ET5.5GB

Table 3-6 Main circuit cable selection of MD500ET0.4GB to MD500ET5.5GB

AC Drive Model	Rated Input Current (A)	Power Input/ Output Cable (mm ²)	Lug Model	Ground Cable (mm ²)	Ground Cable Lug Model	Tightening Torque (N·m)
MD500ET0.4GB	1.8	3 x 0.75	TNR0.75-4	0.75	TNR0.75-4	1.2
MD500ET0.7GB	2.4	3 x 0.75	TNR0.75-4	0.75	TNR0.75-4	1.2
MD500ET1.1GB	3.7	3 x 0.75	TNR0.75-4	0.75	TNR0.75-4	1.2
MD500ET1.5GB	4.6	3 x 0.75	TNR0.75-4	0.75	TNR0.75-4	1.2

3 Installation and Wiring

AC Drive Model	Rated Input Current (A)	Power Input/ Output Cable (mm ²)	Lug Model	Ground Cable (mm ²)	Ground Cable Lug Model	Tightening Torque (N·m)
MD500ET2.2GB	6.3	3 x 0.75	TNR0.75-4	0.75	TNR0.75-4	1.2
MD500ET3.0GB	9.0	3 x 1	TNR1.25-4	1	TNR1.25-4	1.2
MD500ET3.7GB	11.4	3 x 1.5	TNR1.25-4	1.5	TNR1.25-4	1.2
MD500ET5.5GB	16.7	3 x 2.5	TNR2-4	2.5	TNR2-4	1.2

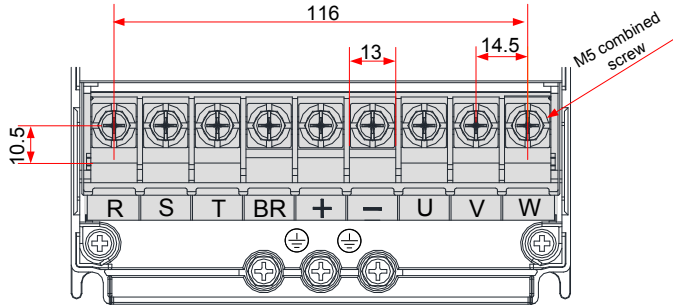

Figure 3-39 Main circuit terminal dimensions of MD500ET7.5GB to MD500ET11GB

Table 3-7 Main circuit cable selection of MD500ET7.5GB to MD500ET11GB

AC Drive Model	Rated Input Current (A)	Power Input/ Output Cable (mm ²)	Lug Model	Ground Cable (mm ²)	Ground Cable Lug Model	Tightening Torque (N·m)
MD500ET7.5GB	21.9	3 x 4	TNR3.5-5	4	TNR3.5-5	2.8
MD500ET11GB	32.2	3 x 6	TNR5.5-5	6	TNR5.5-5	2.8

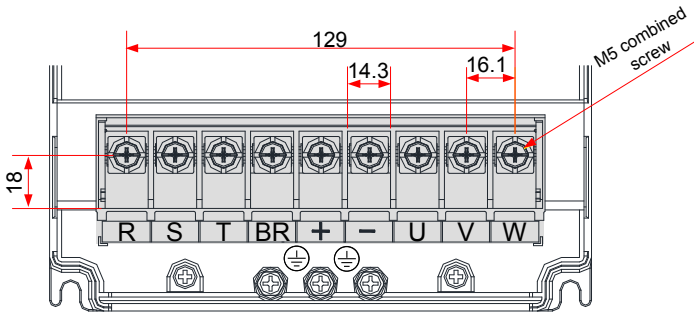

Figure 3-40 Main circuit terminal dimensions of MD500ET15GB

Table 3-8 Main circuit cable selection of MD500ET15GB

AC Drive Model	Rated Input Current (A)	Power Input/ Output Cable (mm ²)	Lug Model	Ground Cable (mm ²)	Ground Cable Lug Model	Tightening Torque (N·m)
MD500ET15GB	41.3	3 x 10	TNR8-5	10	TNR8-5	2.8

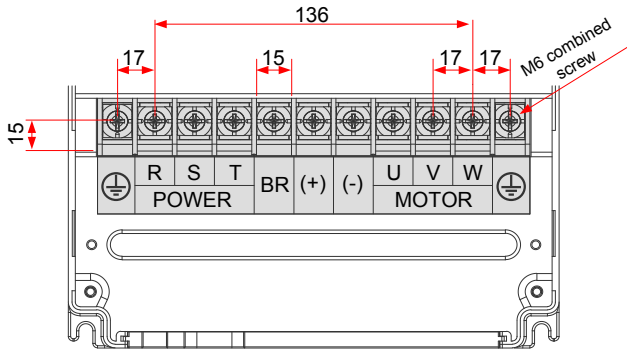

Figure 3-41 Main circuit terminal dimensions of MD500ET18.5G(B)(-T) to MD500ET22G(B)(-T)

Table 3-9 Main circuit cable selection of MD500ET18.5G(B)(-T) to MD500ET22G(B)(-T)

AC Drive Model	Rated Input Current (A)	Power Input/ Output Cable (mm ²)	Lug Model	Ground Cable (mm ²)	Ground Cable Lug Model	Tightening Torque (N·m)
MD500ET18.5G(B)(-T)	49.5	3 x 10	GTNR10-6	10	GTNR10-6	4.0
MD500ET22G(B)(-T)	59.0	3 x 16	GTNR16-6	16	GTNR16-6	4.0

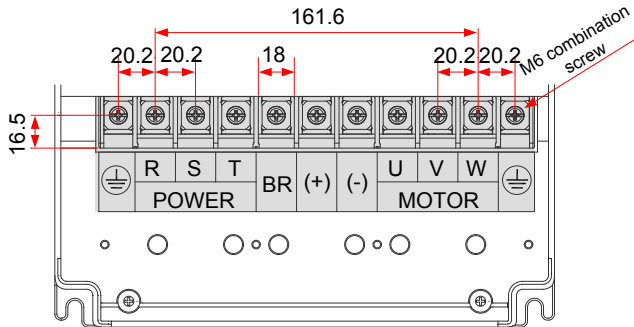

Figure 3-42 Main circuit terminal dimensions of MD500ET30G(B) to MD500ET37G(B)

Table 3-10 Main circuit cable selection of MD500ET30G(B) to MD500ET37G(B)

AC Drive Model	Rated Input Current (A)	Power Input/ Output Cable (mm ²)	Lug Model	Ground Cable (mm ²)	Ground Cable Lug Model	Tightening Torque (N·m)
MD500ET30G(B)	57.0	3 x 16	GTNR16-6	16	GTNR16-6	4.0
MD500ET37G(B)	69.0	3 x 25	GTNR25-6	16	GTNR16-6	4.0

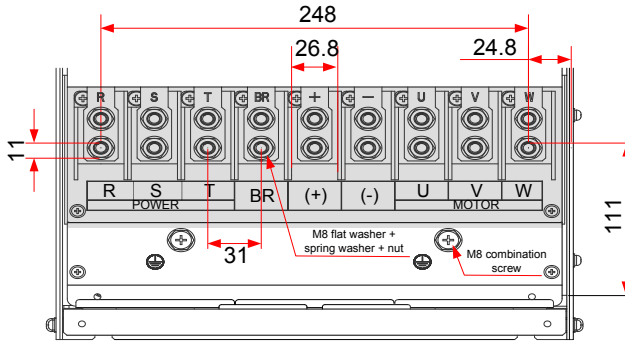

Figure 3-43 Main circuit terminal dimensions of MD500ET45G(B) to MD500ET55G(B)

Table 3-11 Main circuit cable selection of MD500ET45G(B) to MD500ET55G(B)

AC Drive Model	Rated Input Current (A)	Power Input/ Output Cable (mm ²)	Lug Model	Ground Cable (mm ²)	Ground Cable Lug Model	Tightening Torque (N·m)
MD500ET45G(B)	89.0	3 x 35	GTNR35-8	16	GTNR16-8	10.5
MD500ET55G(B)	106.0	3 x 50	GTNR50-8	25	GTNR25-8	10.5

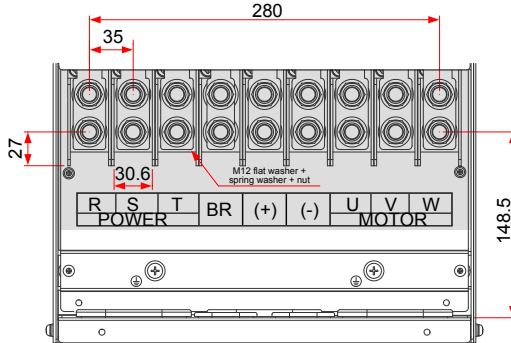

Figure 3-44 Main circuit terminal dimensions of MD500ET75G(B) to MD500ET110G

Table 3-12 Main circuit cable selection of MD500ET75G(B) to MD500ET110G

AC Drive Model	Rated Input Current (A)	Power Input/ Output Cable (mm ²)	Lug Model	Ground Cable (mm ²)	Ground Cable Lug Model	Tightening Torque (N·m)
MD500ET75G(B)	139.0	3 x 70	GTNR70-12	35	GTNR35-12	35.0
MD500ET90G	164.0	3 x 95	GTNR95-12	50	GTNR50-12	35.0
MD500ET110G	196.0	3 x 120	GTNR120-12	70	GTNR70-12	35.0

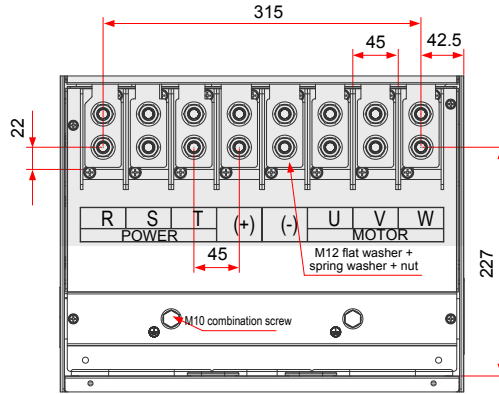

Figure 3-45 Main circuit terminal dimensions of MD500ET132G to MD500ET160G

Table 3-13 Main circuit cable selection of MD500ET132G to MD500ET160G

AC Drive Model	Rated Input Current (A)	Power Input/ Output Cable (mm ²)	Lug Model	Ground Cable (mm ²)	Ground Cable Lug Model	Tightening Torque (N·m)
MD500ET132G	240.0	3 x 150	BC150-12	95	BC95-12	35.0
MD500ET160G	287.0	3 x 185	BC185-16	95	BC95-16	35.0

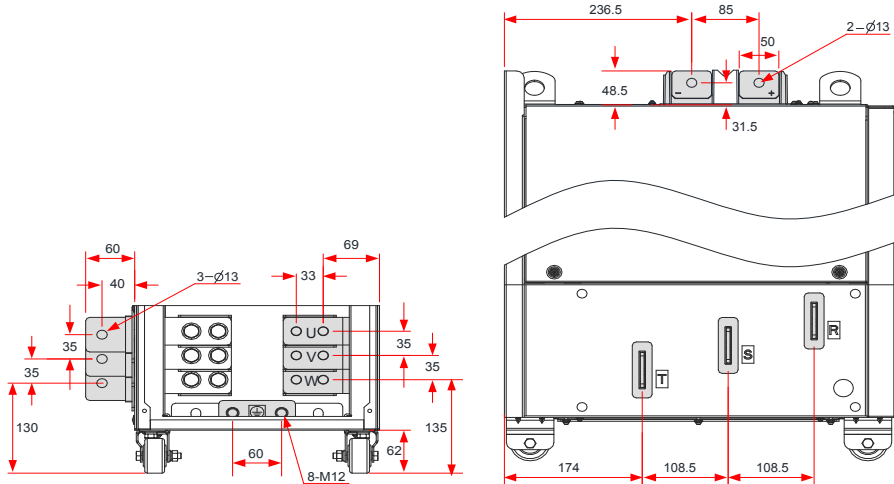

Figure 3-46 Main circuit terminal dimensions of MD500ET200G to MD500ET220G (without output reactor)

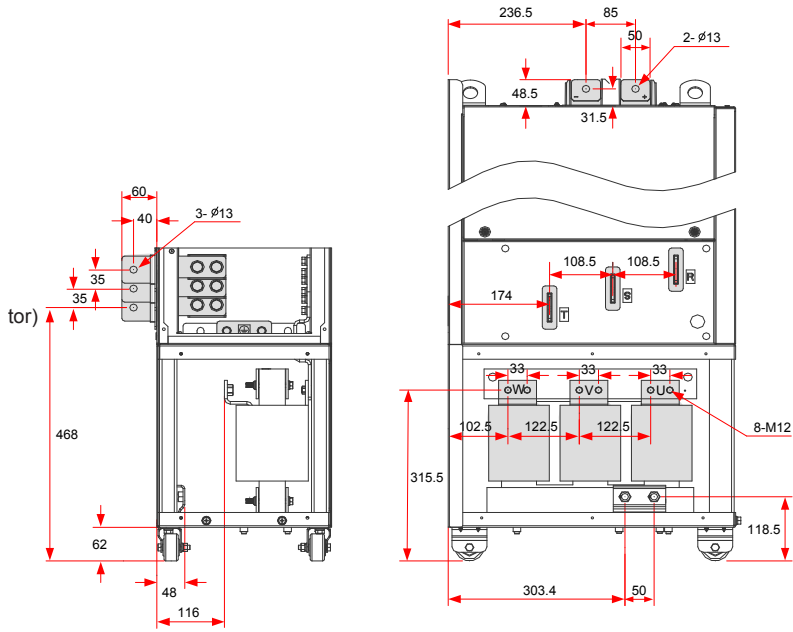

Figure 3-47 Main circuit terminal dimensions of MD500ET200G-L to MD500ET220G-L (with output reactor)

In the above figure, the side entry terminal can be removed if necessary. Terminal dimensions of main circuit terminals without side entry terminal are shown below.

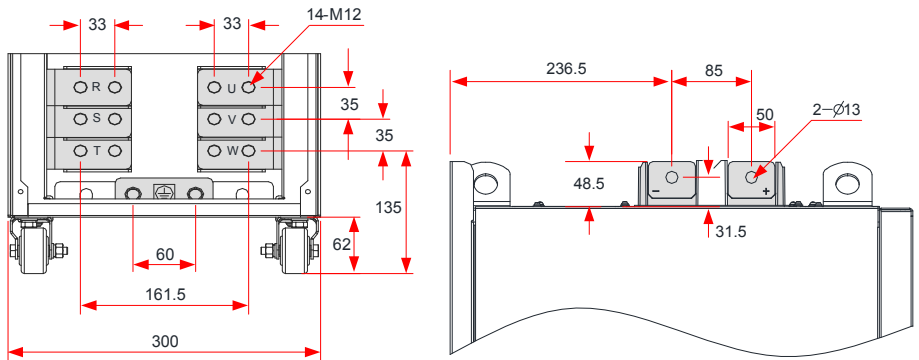

Figure 3-48 Main circuit terminal dimensions of MD500ET200G to MD500ET220G (without side entry terminal, without output reactor)

Table 3-14 Main circuit cable selection of MD500ET200G(-L) to MD500ET220G(-L)

AC Drive Model	Rated Input Current (A)	Power Input/ Output Cable (mm ²)	Lug Model	Ground Cable (mm ²)	Ground Cable Lug Model	Tightening Torque (N·m)
MD500ET200G(-L)	365.0	2 x (3 x 95)	BC95-12	95	BC95-12	35.0
MD500ET220G(-L)	410.0	2 x (3 x 120)	BC120-12	120	BC120-12	35.0

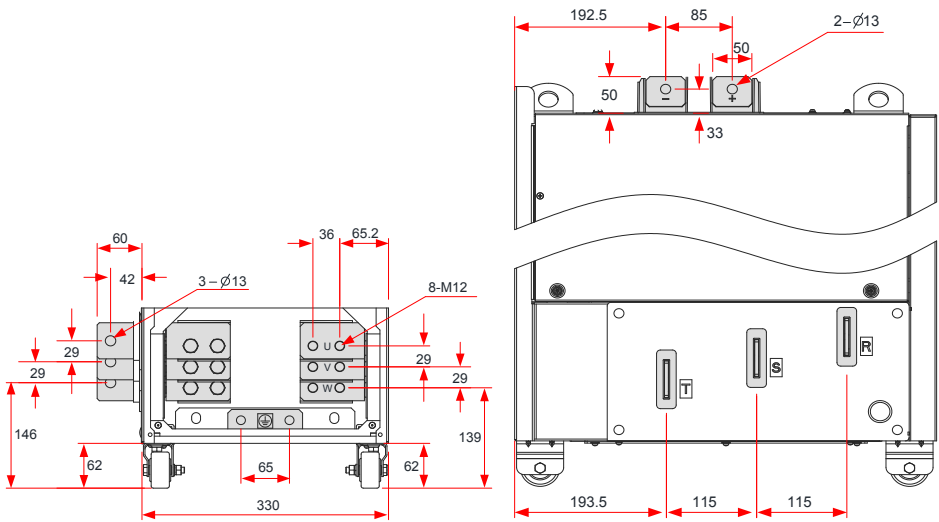

Figure 3-49 Main circuit terminal dimensions of MD500ET250G to MD500ET280G (without output reactor)

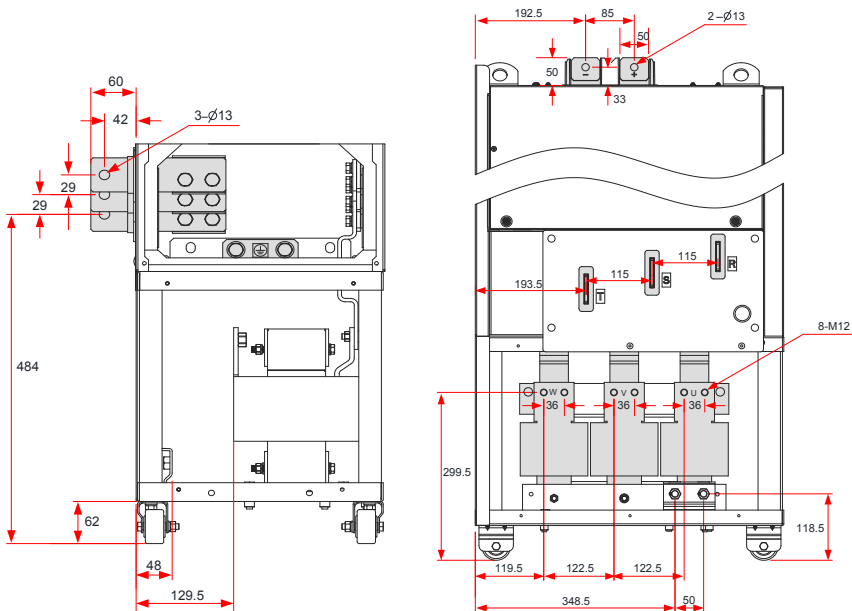

Figure 3-50 Main circuit terminal dimensions of MD500ET250G-L to MD500ET280G-L (with output reactor)

In the above figure, the side entry terminal can be removed if necessary. Terminal dimensions of main circuit terminals without side entry terminal are shown below.

3 Installation and Wiring

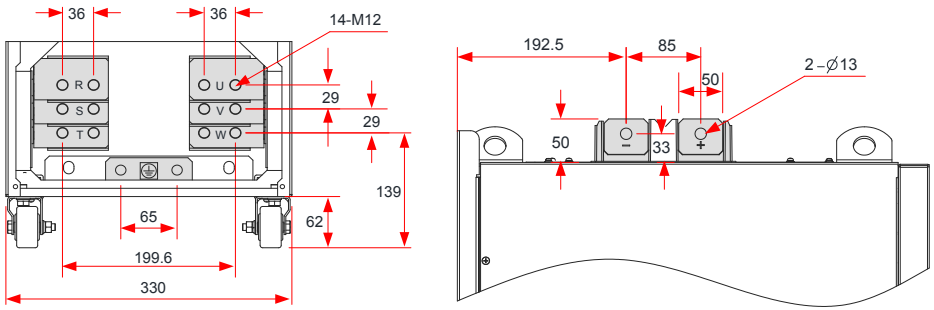

Figure 3-51 Main circuit terminal dimensions of MD500ET250G to MD500ET220G (without side entry terminal, without output reactor)

Table 3-15 Main circuit cable selection of MD500ET250G(-L) to MD500ET280G(-L)

AC Drive Model	Rated Input Current (A)	Power Input/ Output Cable (mm ²)	Lug Model	Ground Cable (mm ²)	Ground Cable Lug Model	Tightening Torque (N·m)
MD500ET250G(-L)	441.0	2 x (3 x 120)	BC120-12	120	BC120-12	35.0
MD500ET280G(-L)	495.0	2 x (3 x 150)	BC150-12	150	BC150-12	35.0

3

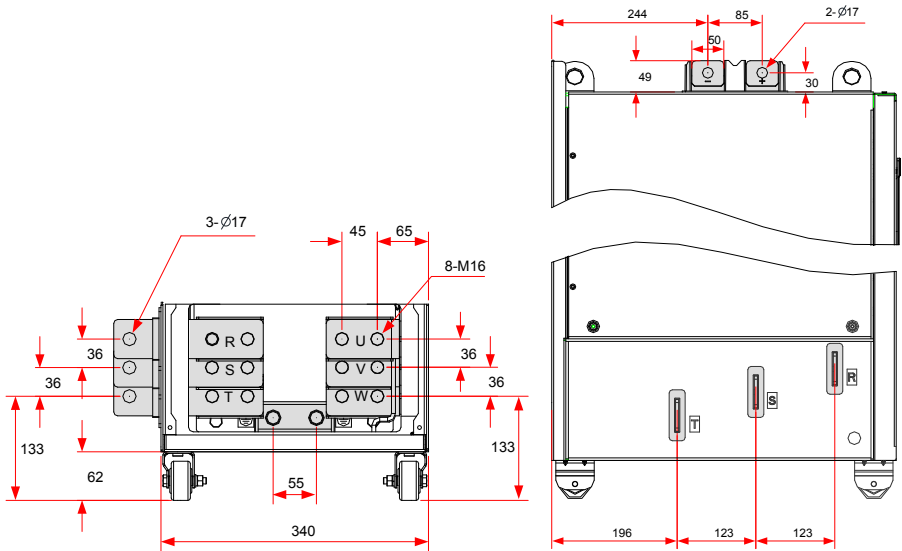

Figure 3-52 Main circuit terminal dimensions of MD500ET315G to MD500ET450G (without output reactor)

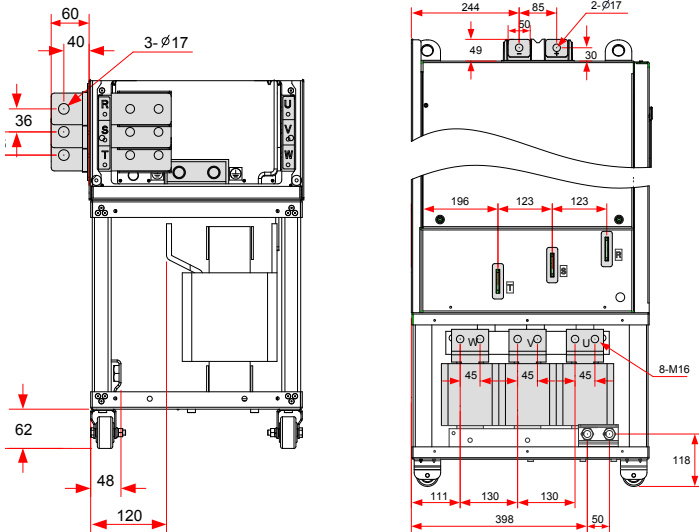

Figure 3-53 Main circuit terminal dimensions of MD500ET315G-L to MD500ET450G-L (with output reactor)

In the above figure, the side entry terminal can be removed if necessary. Terminal dimensions of main circuit terminals without side entry terminal are shown below.

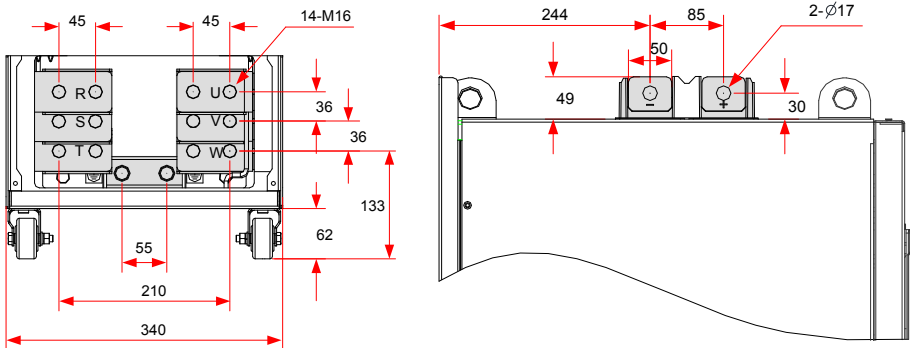

Figure 3-54 Main circuit terminal dimensions of MD500ET315G to MD500ET450G (without side entry terminal, without output reactor)

Table 3-16 Main circuit cable selection of MD500ET315G(-L) to MD500ET450G(-L)

AC Drive Model	Rated Input Current (A)	Power Input/Output Cable (mm ²)	Lug Model	Ground Cable (mm ²)	Ground Cable Lug Model	Tightening Torque (N·m)
MD500ET315G(-L)	565.0	2 x (3 x 185)	BC185-16	185	BC185-16	85.0
MD500ET355G(-L)	617.0	2 x (3 x 185)	BC185-16	185	BC185-16	85.0
MD500ET400G(-L)	687.0	2 x (3 x 240)	BC240-16	240	BC240-16	85.0
MD500ET450G(-L)	782.0	2 x (3 x 240)	BC240-16	240	BC240-16	85.0

3 Installation and Wiring

Recommended lugs are GTNR and BC series lugs manufactured by Suzhou Yuanli Metal Enterprise Co., Ltd.. Description of recommended lugs (manufactured by Suzhou Yuanli Metal Enterprise Co., Ltd.)



Figure 3-55 Appearance of lugs

3.2.4 Control Board

If you need to connect the jumper, PG card or extension card, during control circuit wiring, remove the cover of the AC drive first (for removal steps, refer to Section 3.1.5). The location of control board, jumper and expansion cards are shown in the following figure.

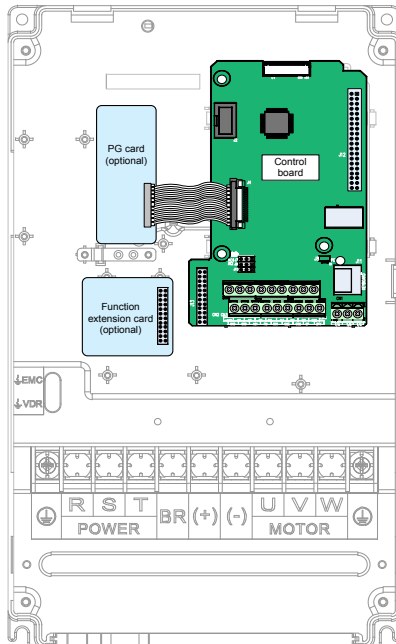

Figure 3-56 MD500E Control Board

3.2.5 Control Circuit Terminal Arrangement

■ Control circuit terminal arrangement

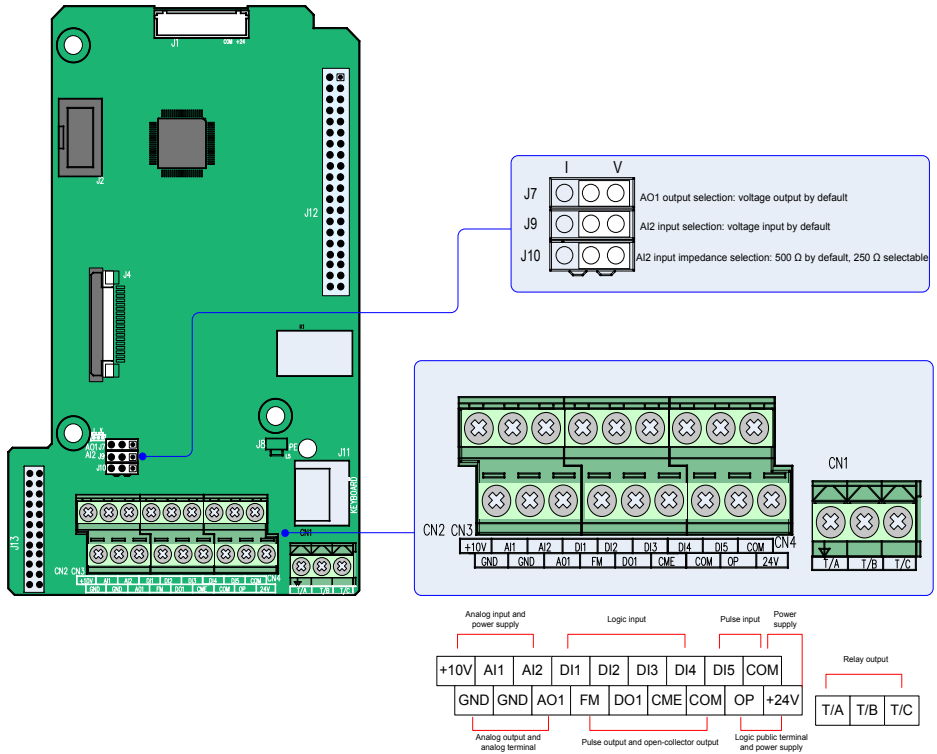

Figure 3-57 Control circuit terminal arrangement

Table 3-17 Control circuit terminal function

Type	Terminal	Terminal Name	Function Description
Power supply	+10V-GND	+10 V power supply	Provides +10 V power supply to an external unit. Max. output current: 10 mA. Generally used to supply an external potentiometer of 1 kΩ to 5 kΩ
	+24V-COM	+24 V power supply	Provide +24 V power supply to an external unit. Generally used for power supply for DI/DO terminals and external sensors. Max. output current: 200 mA ^{<1>}
	OP	Input terminal for external power supply	Connected to +24 V by default. When DI1 to DI5 need to be driven by external signals, OP must be disconnected from + 24 V and connected to an external power supply.
Analog outputs	AI1-GND	Analog input 1	Voltage range of inputs: 0 to 10 VDC Input impedance: 22 kΩ
	AI2-GND	Analog input 2	Either a voltage or a current input, determined by jumper J9 Input voltage range: 0 to 10 VDC Input current range: 0 to 20 mA Input impedance: 22 kΩ (voltage input), 500 Ω or 250 Ω (current input) decided by J10 ^{<2>}

3 Installation and Wiring

Type	Terminal	Terminal Name	Function Description
Digital outputs	DI1- OP	Digital input 1	Optically-coupled isolation compatible with dual-polarity inputs Input impedance: 1.39 k Ω Voltage range for inputs: 9 to 30 V
	DI2- OP	Digital input 2	
	DI3- OP	Digital input 3	
	DI4- OP	Digital input 4	
	DI5- OP	High-speed pulse input	In addition to having the same features as DI1 to DI4, DI5 can also be used for high speed pulse inputs. Max. input frequency: 100 kHz Input impedance: 1.03 k Ω
Analog outputs	AO1-GND	Analog output 1	Either a voltage or a current output, determined by jumper J7. Output voltage range: 0 to 10 V Output current range: 0 to 20 mA
Digital outputs	DO1-CME	Digital output 1	Optically-coupled isolation, dual-polarity open-collector output Output voltage range: 0 to 24 V Output current range: 0 to 50mA Note that CME and COM are internally insulated, but are shorted externally by a jumper. In this case, DO1 is driven by +24 V by default. Remove the jumper link if you need to apply external power to DO1.
	FM- COM	High-speed pulse output	Controlled by F5-00 (FM terminal output selection). Max. output frequency: 100 kHz. When used as an open-collector output, the specification is the same as for DO1.
Relay outputs	T/A-T/B	Normally-closed (NC) terminal	Contact driving capacity: 250 VAC, 3 A, Cos Φ = 0.4 30 VDC, 1 A
	T/A-T/C	Normally-open (NO) terminal	
Auxiliary interfaces	J13	Extension card interface	Interface for the 28-core terminal and optional cards (I/O extension card, PLC card and various bus cards)
	J4	PG card interface	Open-collector, differential and Resolver are selectable options.
	J11	External operating panel interface	Connected to an external operating panel.
Jumpers ^{<2>}	J7	AO1 output selection	Either a voltage or a current output, voltage output by default
	J9	AI2 input selection	Either a voltage or a current input, voltage input by default
	J10	AI2 input impedance selection	Either 500 Ω or 250 Ω input, 500 Ω input by default

- <1> When the ambient environment is above 23°C, the output current must be de-rated for 1.8 mA per 1°C temperature rise. The maximum output current is 170 mA at 40°C. When OP is connected to 24 V, the current of the DI shall also be considered.
- <2> Select 500 Ω or 250 Ω input impedance according to with-load capacity of signal source. For example, if 500 Ω is selected, maximum output voltage of signal source must not be smaller than 10 V so that AI2 can measure 20 mA current.
- <3> For positions of jumpers J7, J9 and J10, refer to Figure 3-57.

4 Panel Operation

4.1 Introduction

The AC drive has an inbuilt programming/operating panel with LED or LCD indicators and display. It allows you to operate function parameters and monitor/control system status.

A remote/external LED (MD32NKE1) or LCD (MDKE9) operating panel is available as an option. The LED operating panel allows you to modify and view parameters. For its appearance and use, refer to Section 4.2. The LCD operating panel allows you to copy, upload and download parameters. For its appearance, see Section 4.3.

4.2 LED Operating Panel

The LED operating panel allows you to set and modify function parameters, monitor system status, start or stop the AC drive. Details of the operating panel are shown in the following figure.

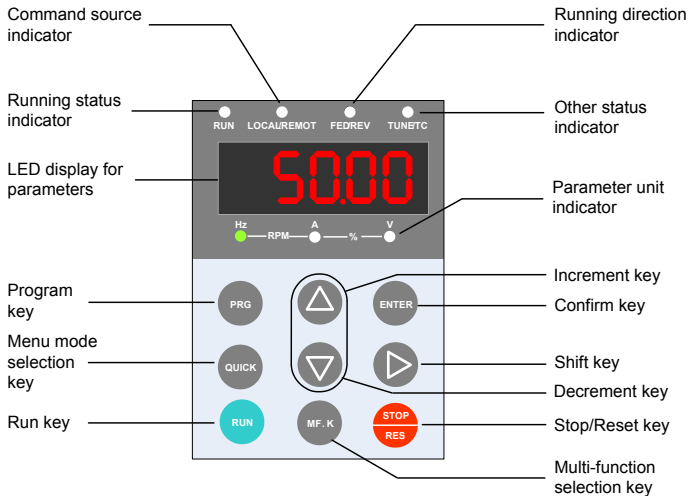

Figure 4-1 Details of the operating panel

4.2.1 Indicators on LED Operating Panel





























 indicates the light turns on,  indicates the light turns off.  indicates the light flashes.

Table 4-1 Indicators on the operating panel

	State	Indication
RUN Running status indicators	 RUN	OFF indicates the STOP status.
	 RUN	ON indicates the RUNNING status.
LOCAL/REMOT Running command indicators	 LOCAL/REMOT	OFF indicates under operating panel control.
	 LOCAL/REMOT	ON indicates under terminal control.
	 LOCAL/REMOT	FLASHING indicates under serial communication control.
FWD/REV Forward and reverse rotation indicators	 FWD/REV	OFF indicates reverse motor rotation.
	 FWD/REV	ON indicates reverse motor rotation.
TUNE/TC Tuning, torque control and fault indicators	 TUNE/TC	OFF indicates the drive is normal.
	 TUNE/TC	ON indicates torque control mode.
	 TUNE/TC	FLASHING SLOWLY (once a second) indicates auto-tuning status.
	 TUNE/TC	FLASHING QUICKLY (four times a second) indicates a fault condition.
 Hz — RPM —  A — % —  V		Hz for frequency
 Hz — RPM —  A — % —  V		A for current
 Hz — RPM —  A — % —  V		V for voltage
 Hz — RPM —  A — % —  V		RPM for motor speed
 Hz — RPM —  A — % —  V		Percentage

4.2.2 LED Display









The five-digit LED data display can show the frequency reference, output frequency, monitoring information, and fault code.

Table 4-2 Indication of LED display

LED display	Indication	LED display	Indication	LED display	Indication	LED display	Indication
0	0	6	6	C	C	n	N
1	1	7	7	c	c	P	P
2	2	8	8	d	D	r	R
3	3	9	9	E	E	T	T
4	4	A	A	F	F	U	U
5	5, S	b	B	L	L	u	u

4.2.3 Keys on LED Operating Panel

Table 4-3 Function of keys on the LED operating panel

Key	Key Name	Function
	Programming	Enter or exit Level 1 menu.
	Confirm	Enter each level of menu interface and confirm displayed parameter setting.
	Increment	When editing a parameter value, it increases the displayed value.
	Decrement	When editing a parameter value, it decreases the displayed value.
	Shift	Select the displayed parameter in the STOP or RUNNING status. Select the digit to be modified when modifying a parameter value.
	RUN	Start the AC drive when using the operating panel control mode.
	Stop/Reset	Stop the AC drive when the drive is in the RUNNING status. The functions of this key can be restricted by using function F7-02. Perform a reset operation when the drive is in the FAULT status.
	Multifunction	Perform a function switchover as defined by the setting of F7-01. For details, refer to "4.2.7 Multifunction".
	Menu mode selection	Press it to switch over between menu modes as defined by the setting of FP-03.

4.2.4 View and Modify Function Parameters

The drive operating panel has three levels of menu:

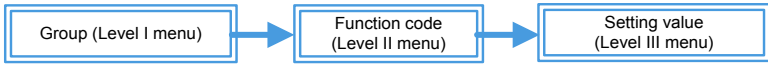

After entering each level of menu, you can press , , or  to modify the flashing value. Operation procedure is shown in Figure 4-2.

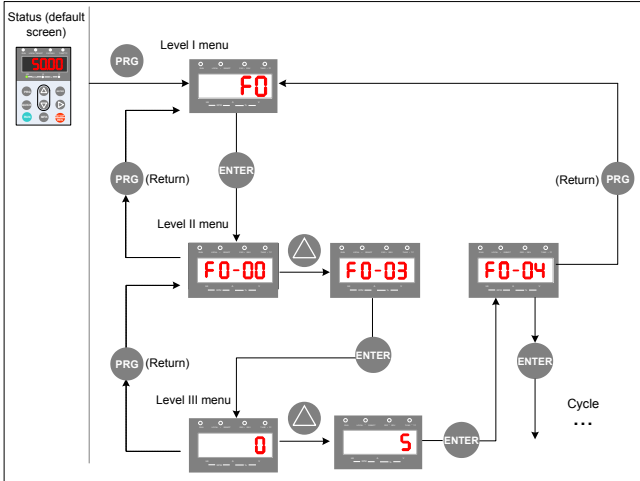

Figure 4-2 Operation procedure of the three levels of menu

The following example shows how to modify F3-02 from 10.00 Hz to 15.00 Hz.

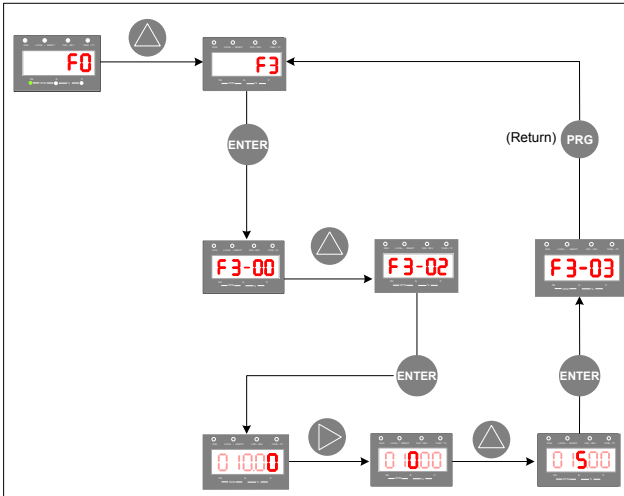

Figure 4-3 How to modify the parameter value

- Press **PRG** or **ENTER** from a Level III menu to return to a Level II menu. The difference between the two keys is: **ENTER** is used to save the parameter value you have set, return to Level II menu and then select the next function parameter. **PRG** is used to return to Level II menu without saving the parameter value and remain at the current function code.
- (When operating in Level III menus, if the parameter does not include a flashing digit, then it is not possible to modify that parameter. There are two possible reasons for this:
 - The function parameter you have selected is read-only. This is because the display is showing the AC drive model; the display is showing an actual parameter detected by the system; or the display is showing a running record parameter.
 - The displayed function parameter cannot be modified while the AC drive is in the RUNNING status. You can modify these types of parameter only when the AC drive is in the STOP status.

4.2.5 Overall Arrangement of Function Parameters

Table 4-4 Overall arrangement of function parameters

Function Code Group	Function Description	Description
F0 to FP A0 to AC	Basic function parameters	Displays parameters such as running commands, frequency commands, motor parameters, control modes, AI/AO characteristic correction, and optimization control
U0	Monitoring function parameter group	Displays basic monitoring parameters

Before viewing function parameters, set FP-02 (SELECTED) to see whether the function parameter group is displayed. The following figure shows how to view the function parameter group number:

Function Code	Function Code	Default	Setting Range	Description
FP-02	Parameter display property	11	Unit's digit: Group U is displayed. 0: Not displayed; 1: Displayed Ten's digit: Group A is displayed. 0: Not displayed; 1: Displayed	The value you set for function parameter GP-02 determines whether the operating panel displays groups U and A.

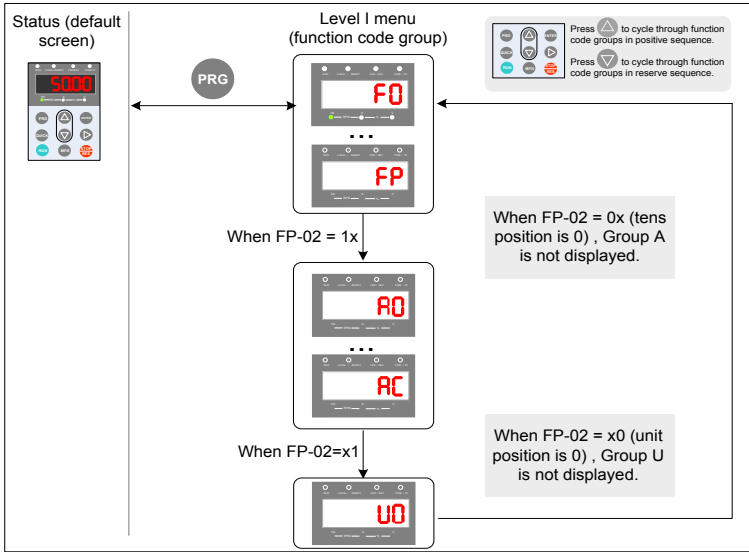

Figure 4-4 View the function parameter group number

4.2.6 View Function Parameters

The drive provides three display modes for viewing parameters. In base mode, all function parameters are shown. You can set the function code FP-03 to quick view function parameters in two other modes.

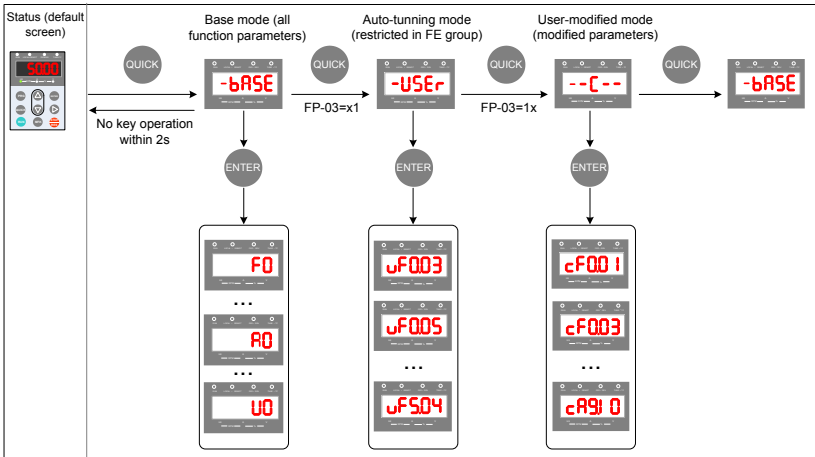

Figure 4-5 View the function parameters

In the figure above, in user-defined quick-view mode, the parameter is displayed as "uF3.02". It means the function parameter F3-02 can be modified in user-modified quick-view mode and base mode in the same way.

Function parameter display modes are as follows:

Mode	Display	Description
User-defined quick-view mode		Show function parameters that are defined by a user
User-modified quick-review mode		Show function parameter whose value is different from the default value
Base mode		Show all function parameters in sequence

1. Base mode

In base mode, all function parameters of the drive are shown. You can view or edit the parameters according to section 4.2. Press to cycle through three function parameter display modes. In each mode, the method you use to view and modify parameter value is the same as shown in 4.2.

2. Quick-view mode

To show function parameters that are defined or modified by a user, set the FP-03 value to 11.

Function Code	Function Code	Default	Setting Range	Description
FP-03	Parameter display property	00	Unit's digit: group is displayed 0: Not displayed; 1: Displayed Ten's digit: group is displayed. 0: Not displayed; 1: Displayed	Determine whether the operating panel displays quick-view user-defined and quick-view user modified function groups.

■ View quick-view user-defined function parameter group

Press to enter the mode. Then the user can view the user-defined function parameters.

The user can set the function group FE (FE-00 to FE-29) to define often used function parameters. The user can define up to 30 parameters to the function group FE. The function parameters FE00 to FE-15 (16 in total) are default and can be edited by the user. If a function code in group FE is set to F0.00, it indicates that no parameter is defined by the user. If is displayed after you press , it indicates that the user-defined menu is empty. The following table lists the often used parameters in the user-defined menu.



Table 4-5 Often used parameters in the user-defined menu

Function Code	User-defined Function Code	Name	Function Code	User-defined Function Code	Name
FE-00	F0-01	Control mode	FE-01	F0-02	Command source selection
FE-02	F0-03	Main frequency reference setting channel selection	FE-03	F0-07	Frequency source calculation selection
FE-04	F0-08	Preset frequency	FE-05	F0-17	Acceleration time
FE-06	F0-18	Deceleration time	FE-07	F3-00	V/F curve setting
FE-08	F3-01	Torque boost	FE-09	F4-00	DI1 function selection
FE-10	F4-01	DI2 function selection	FE-11	F4-02	DI3 function selection

4 Panel Operation

Function Code	User-defined Function Code	Name	Function Code	User-defined Function Code	Name
FE-12	F5-04	DO1 output selection	FE-13	F5-07	AO1 output selection
FE-14	F6-00	Start mode	FE-15	F6-10	Stop mode

■ View user modified function parameters

Press  to enter the  mode to view function parameters that have been modified.

In this mode, you can view modified function parameters quickly. All function parameters that have been modified by a user are listed in the modified function parameter group. The current values of these parameters are different from the default values. The AC drive automatically generated a list of modified function parameters.

3. View status parameters

When the drive in STOP or RUNNING state, press  to switch each byte of F7-03, F7-04, an F7-05 to display multiple status parameters.

A maximum of 32 parameters in the running status can be viewed in F7-03 (running parameter 1) and F7-04 (running parameter 2) based on each bit selection in binary. At stop, a total of 13 parameters can be viewed in F7-05 (STOP parameter) based on each bit selection in binary.

You can use the operating panel to view running frequency, bus voltage, output voltage, output current, output power and PID reference.

- (1) Set each bit of F7-03 to 1 according to the mapping between each bit and the corresponding parameter.
- (2) Convert binary number to equivalent hexadecimal number. H.001F is displayed.
- (3) Press  to convert each bit of F7-03. The reference is as follows:

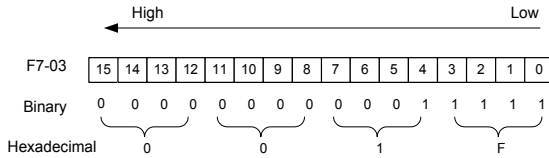

4

You can view the other parameters in the same way. The mapping of each bit of F7-03, F7-04, and F7-05 is shown in the following figure:

Function Code	Function Definition	Default	Setting Range	Description
F7-03	LED display running parameters 1	1F	0000 to FFFF	<p>If a parameter needs to be displayed during running, set corresponding bit to 1, and set F7-03 to hexadecimal equivalent.</p> <p>Lowest eight digits</p> <p>Highest eight digits</p> <p>Note: Values with shading are default values.</p>
F7-04	LED display running parameters 2	0	0000 to FFFF	<p>If a parameter needs to be displayed during running, set corresponding bit to 1, and set F7-04 to hexadecimal equivalent.</p> <p>Lowest eight digits</p> <p>Highest eight digits</p>

4 Panel Operation









Function Code	Function Definition	Default	Setting Range	Description
F7-05	LED display stop parameters	0	0000 to FFFF	<p>If a parameter needs to be displayed during stop, set corresponding bit to 1, and set F7-05 to hexadecimal equivalent.</p> <p>Lowest eight digits</p> <p>Highest eight digits</p> <p>Note: Values with shading are default values.</p>

Note

- Once the AC drive is re-powered on after power down, the display includes the selected parameters before power down by default.

4.2.7 MF.K Key Function

Function of the  key on the LED operating panel can be set via function parameter F7-01. You can switch over running command or frequency reference direction of the drive and implement forward/reverse jog through this key in either STOP or RUNNING status.

Function Code	Function Code	Default	Setting Range	Description
F7-01	 key function selection	0	0:  disabled	The key has no function.
			1. Switchover between operating panel and terminal/communication.	F0-02 = 0, there is no effect after you press the  key. F0-02 = 1, running command can be switched over between terminal and operating panel through the  key. F0-02 = 2, communication source can be switched over between communication and operating panel through the  key.
			2. Forward/Reverse RUN switchover	Frequency reference direction can be switched over through the  key. This function is valid only when running command is operating panel.
			3: Forward jog	Forward jog of the drive can be implemented through the  key. This function is valid only when running command is operating panel.
			4: Reverse jog	Reverse jog of the drive can be implemented through the  key. This function is valid only when running command source is operating panel.

4.3 External LCD Operating Panel

External LCD operating panel MDKE9 (optional) allows you to copy, download and modify parameters conveniently. Details of the operating panel are shown in the following figure.

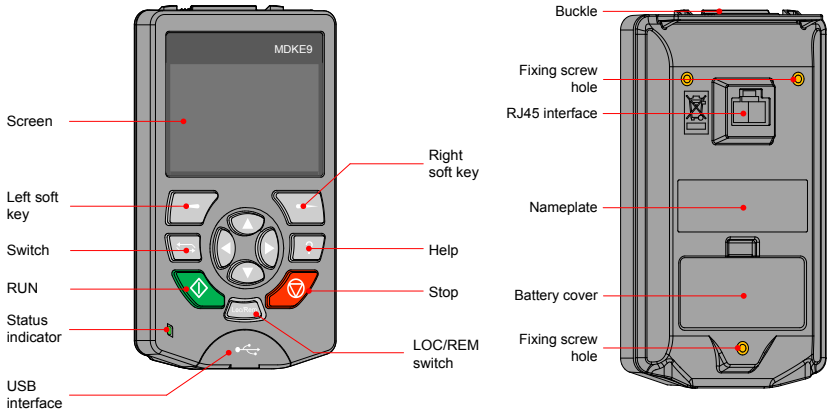

Figure 4-6 Appearance of the external LCD operating panel (MDKE9)

Note

- External LCD operating panel MDKE9 supports Chinese and English.

5 Basic Operations and Trial Run

This chapter describes basic operations and trial run of the AC drive, mainly including setting the frequency reference, and stopping and starting the drive.

5.1 Quick Commissioning Guide

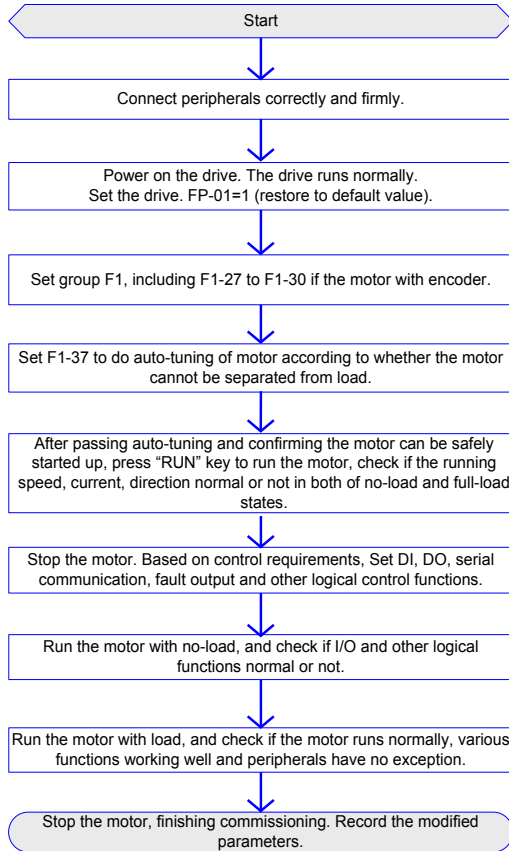

Figure 5-1 Quick commissioning steps

5.2 Commissioning Flowchart

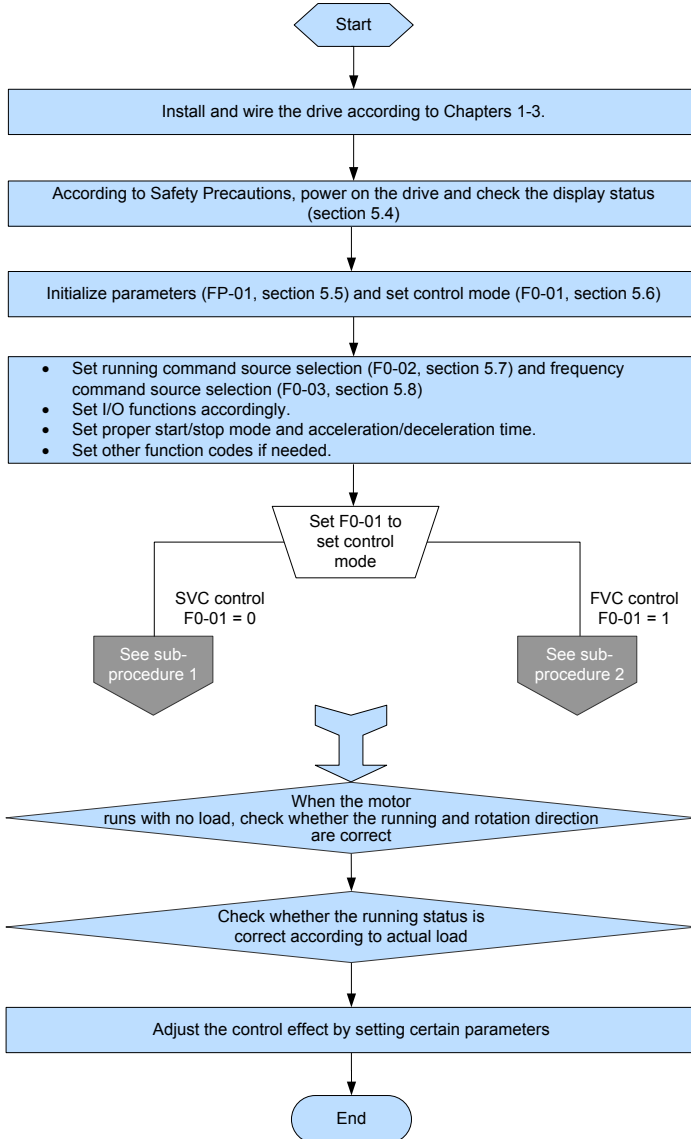

Figure 5-2 Commissioning flowchart

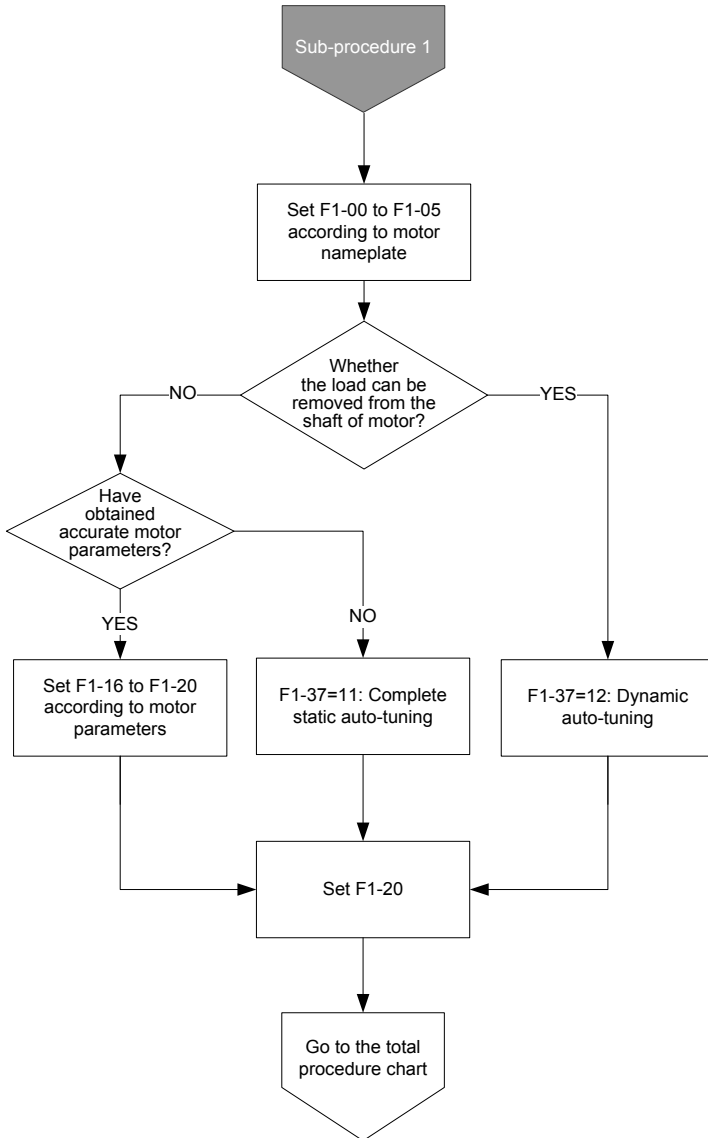

Figure 5-3 Commissioning subprocess flowchart 1 (SVC control)

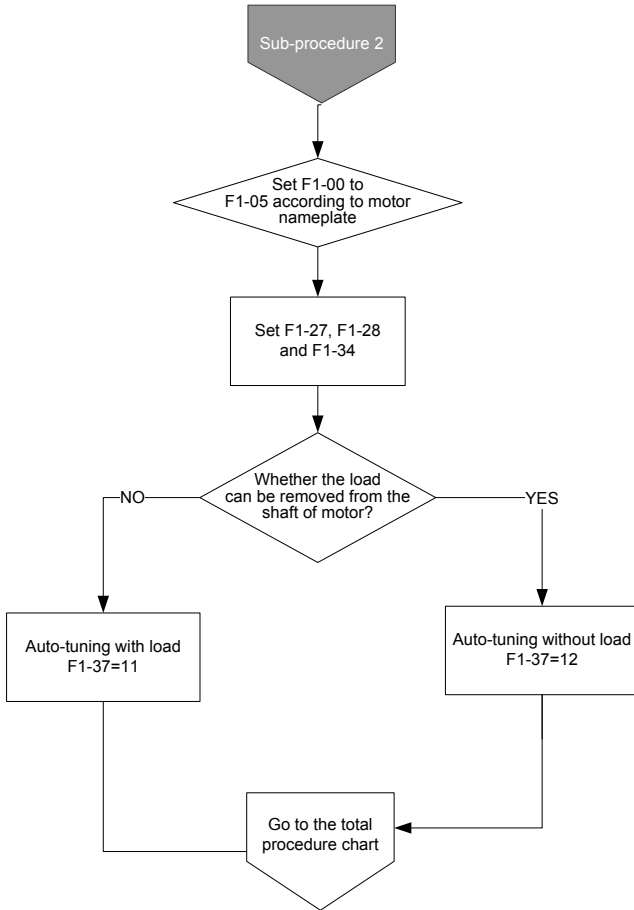

Figure 5-4 Commissioning subprocess flowchart 2 (Vector control (FVC))



5.3 Checklist Before Power-on

Be sure to check the following items before powering on the drive.

Item	Content
Voltage	The voltage is AC 380 to 480 V and 50/60 Hz.
	The input connects R, S, and T are properly connected.
	The drive is connected to the motor properly.
Connection of drive output terminals and motor terminals	The drive output terminals U, V and W are firmly connected to the motor terminals.
Connection of terminals in control circuit	Terminals of the control circuit are firmly connected to other control devices.
Status of control terminals	All terminals of the control circuit are OFF (the drive is not running).
Load	The motor is idle and not connected to the mechanical system.

5.4 Display After Power-on

After the drive is powered on, the display on operating panel is described in the following table.

State	Display	Description
Normal		Default value 50.00 Hz is displayed.
After the fault occurs		The drive stops and displays error code.

5.5 Parameter Initialization

You can restore the drive to factory parameters. After initialization, FP-01 is automatically zeroed.

FP-01	Parameter initialization		Default	0	
	Setting Range	0	No operation		
		1	Restore factory parameters except motor parameters		
		2	Clear records		
		4	Back up current user parameters		
		501	Restore user backup parameters		

1: Restore factory parameters except motor parameters

When FP-01 is set to 1, most of the parameters are restored to the factory default settings. However, motor parameters, frequency reference resolution (F0-22), error records, accumulative running time (F7-09), accumulative power-on time (F7-13), accumulative power consumption (F7-14), and heatsink temperature of AC drive IGBT (F7-07) cannot be restored.

2: Clear records

Error records, F7-09, F7-13, and F7-14 are cleared.

4: Back up current user parameters

Parameters set by the current user are backed up. Values of all the current function parameters are backed up for restoration after error caused by parameter adjustment.

501: Restore user backup parameters

Restore parameters backed up by setting FP-01 to 4.

5.6 Motor Control

Function Code	Description	Scenario
F0-01: Motor control mode	F0-01 = 0: SVC	It indicates the SVC control mode. It is applicable for common high-performance control scenarios in which one AC drive can drive only one motor, for example, machine tool, centrifuge, drawing machine, and injection molding machine.
	F0-01 = 1: FVC	It indicates the FVC control mode. The motor must have an encoder and the drive must have a PG card in the same type of the encoder. It is applicable to scenarios requiring high precision speed or torque control. One AC drive can drive only one motor, for example, high-speed paper making machine, crane and elevator.

5.7 Start/Stop running command

F0-02	Running command selection		Default	0
	Setting Range	0	Operating panel (LED off)	
		1	Terminal (LED on)	
		2	Serial communication (LED flashing)	

You can use F0-02 to select input channel of the drive running command. The drive running commands include start, stop, forward, reverse, and jog.

F0-02 = 0: Operating panel (The LOCAL/REMOT indicator is off.)

The commands are given by pressing the RUN and STOP/RES on the operating panel.

F0-02 = 1: Terminal (The LOCAL/REMOT indicator is on.)

Commands are given by using multi-functional input terminals with functions such as FWD, REV, JOGF and JOGR.

F0-02 = 2: Serial communication (The LOCAL/REMOT indicator is flashing.)

5.7.1 Start/Stop Operating Panel

The commands are given by pressing the RUN and STOP/RES on the operating panel, and the LOCAL/REMOT indicator is off. For information about the keys, refer to Chapter 4 Panel Operations.

5.7.2 Start/Stop DI

F4-11	Terminal I/O control mode		Default	0
	Setting Range	0	Two-wire control mode 1	
		1	Two-wire control mode 2	
		2	Three-wire control mode 1	
		3	Three-wire control mode 2	

F4-11 defines the four terminal I/O control modes, in which the drive running is controlled by DI terminals.

The following example takes DI1, DI2 and DI3 to describe how to control the AC drive via DI terminals. Set F4-00 to F4-02 to select DI1, DI2 and DI3. For details, see setting ranges of F4-00 to F4-09.

F4-11 = 0: Two-wire Control Mode 1. It is the most commonly used two-wire control mode. Allocate DI1 with forward run function and DI2 with reverse run function.

The parameters are set as below:

Function Code	Name	Value	Function Description
F4-11	Terminal I/O control mode	0	Two-wire control mode 1
F4-00	DI1 function selection	1	Forward RUN (FWD)
F4-01	DI2 function selection	2	Reverse RUN (REV)

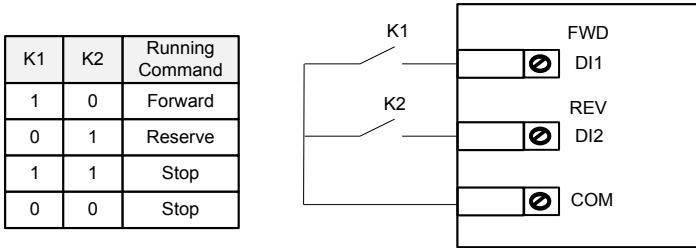

Figure 5-5 Two-wire control mode 1

In this mode, when K1 is closed, drive rotates in forward direction. When K2 is closed, drive rotates in reverse direction. When K1 and K2 are both open or closed simultaneously, drive stops.

F4-11 = 1: Two-wire Control Mode 2. In this mode, DI1 is RUN enabled terminal, and DI2 determines running direction.

The parameters are set as below:

Function Code	Name	Value	Function Description
F4-11	Terminal I/O control mode	1	Two-wire control mode 2
F4-00	DI1 function selection	1	RUN enabled
F4-01	DI2 function selection	2	Reverse RUN

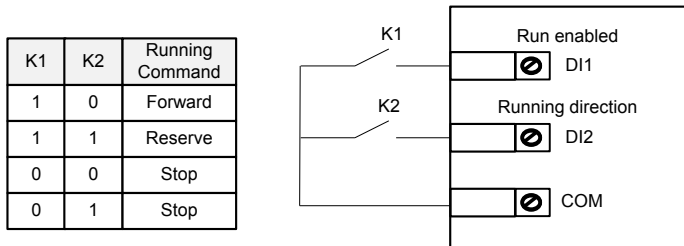

Figure 5-6 Two-wire control mode 2

In this mode, when K1 is closed, motor rotates in forward direction with K2 open. When K1 is closed, motor rotates in reverse direction with K2 closed. When K1 is open, motor stops no matter whether K2 is open or closed.

F4-11 = 2: Three-wire Control Mode 1. In this mode, DI3 is three-wire control terminal. DI1 is set for forward run function and DI2 is set for reverse run function.

The parameters are set as below:

Function Code	Name	Value	Function Description
F4-11	Terminal I/O control mode	2	Three-wire control mode 1
F4-00	DI1 function selection	1	Forward RUN (FWD)
F4-01	DI2 function selection	2	Reverse RUN (REV)
F4-02	DI3 function selection	3	Three wire control

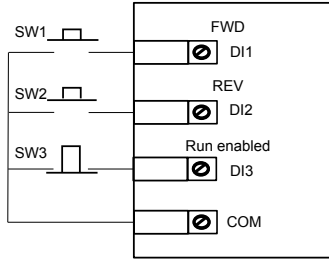

Figure 5-7 Three-wire control mode 1

In this mode, on normal condition (SW3 closed), after you press down SW1, motor rotates in forward direction. After you press down SW2, motor rotates in reverse direction. Motor stops immediately when SW3 opens. SW3 must remain closed during START sequence and during normal RUN operation. Signals from SW1 and SW2 are valid only with SW3 closed. The motor status is determined by the key that you last press down.

F4-11 = 3: Three-wire Control Mode 2. In this mode, DI3 is three-wire control terminal. DI1 determines whether the RUN command is enabled and DI2 determines running direction.

The parameters are set as below:

Function Code	Name	Value	Function Description
F4-11	Terminal I/O control mode	3	Three-wire control mode 2
F4-00	DI1 function selection	1	RUN enabled
F4-01	DI2 function selection	2	Reverse RUN
F4-02	DI3 function selection	3	Three wire control

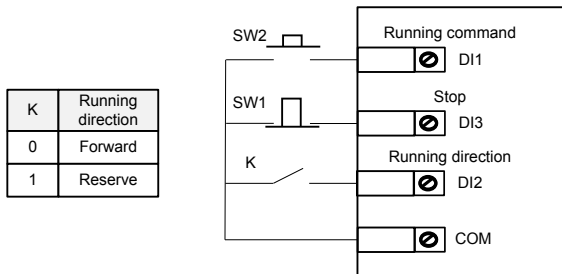

Figure 5-8 Three-wire control mode 2

In this mode, when SW1 is closed, after you press down SW2, motor rotates in forward direction with K open and in reverse direction with K closed. Motor stops immediately when SW1 opens. SW1 must remain closed during START sequence and during normal RUN operation. Signals from SW2 are valid only with SW1 closed.

5.7.3 Start/Stop via Communication

The controller can start/stop the AC drive via various communications. When using communication functions, the relative parameters F0-02 and F0-28 are needed to be set according to different communication types, refer to the following table. In addition, an optional communication extension card is needed. For information about optional communication cards, refer to Appendix A Expansion Optional Cards.

Setting Procedure	Function Code	Description	
Use frequency command to set the serial communication mode	F0-02	F0-02 = 2	
Select serial communication mode	F0-28	Modbus protocol	F0-28 = 0
		PROFIBUS-DP protocol	F0-28 = 1
		CANopen protocol	F0-28 = 1
CANlink is always valid and does not need to be set.			

5.8 Start the AC Drive

5.8.1 Start Mode

F6-00	Start mode		Default	0
	Setting Range	0	Direct Start	

0: Direct start

If the DC injection braking time is set to 0, the drive will start from the setting start-up frequency (F6-03). If the DC injection braking time is not set to 0, the drive will start DC braking firstly and then start from the setting start-up frequency (F6-03). This DC injection braking function is applicable to small-inertia loads which is easy to slip during startup stage.

It is applicable to most small-inertia loads, the frequency curve is shown in the following figure. The DC injection braking function is applicable to drive load such as elevator and crane. Start frequency is applicable to drive equipment which requires startup torque, such as cement mixer.

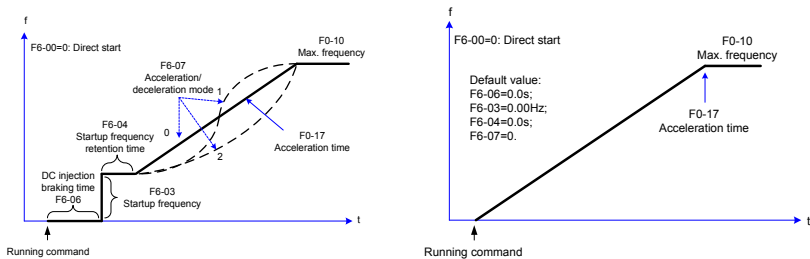

Figure 5-9 Direct start

5.8.2 Start Frequency

F6-03	Start frequency	Default	0.00 Hz
	Setting Range	0.00 Hz to 10.00 Hz	
F6-04	Start frequency holding time	Default	0.0s
	Setting Range	0.0s to 100.0s	

Set an appropriate start frequency to ensure the motor torque when the motor starts. The start frequency needs to be retained for a period of time for full magnetic flux when the motor starts.

F6-03 has no lower frequency limit. If target frequency is smaller than start frequency, the motor does not start and is idle.

Retention time of start frequency is not counted into acceleration time but into running time of simple PLC function.

5.9 View Running Status

5.9.1 Digital Output (DO)

There are three digital output terminals on the control board. FM and DO1 are transistor outputs capable of driving a 24 V DC low-voltage circuit. TA/TB/TC is a relay capable of driving a 250 V AC control circuit.

There are two additional digital outputs on the optional I/O extension board. DO2 is a transistor output and PA/PB/PC is a relay output.

Function codes F5-01 to F5-05 define how DO terminals indicate the running status and alarm information for the AC drive. There are about 40 functions available to use for these function codes.

Terminal	Corresponding Function Code	Output Feature Description
FM-COM	F5-06 when F5-00 = 0	Transistor Able to output high-speed pulses 10 Hz to 100 kHz Drive capacity: 24 VDC, 50 mA
	F5-01 when F5-00 = 1	Transistor Drive capacity: 24 VDC, 50 mA
TA-TB-TC	F5-02	Relay Drive capacity: 250 VAC, 3 A
PA-PB-PC	F5-03	Extension card, relay Drive capacity: 250 VDC, 3 A
DO1-CME	F5-04	Transistor Drive capacity: 24 VDC, 50 mA
DO2-CME	F5-05	Extension card, transistor Drive capacity: 24 VDC, 50 mA

When F5-00 = 0, FM terminal is high-speed pulse output. Frequency of pulses on this DO terminal indicates the value of internal running parameters. Higher values of internal running parameters produce higher pulse frequencies. Value 100% corresponds to a pulse frequency of 100 kHz. F5-06 indicates attributes of internal running parameters.

5.9.2 Analog Output (AO)

The drive supports a maximum of two analog output terminals. AO1 is on the control board and AO2 is on the optional extension card. F5-07 and F5-08 define how AO terminals indicate the drive internal running parameters in analog mode.

Terminal	Input Signal Characteristics
AO1-GND	If J7 jumps to the "V" position, AO outputs voltage signal of 0 to 10 VDC.
	If J7 jumps to the "I" position, AO outputs current signal of 0 to 20 mA.
AO2-GND	It is on the optional extension card. It outputs voltage signal of 0 to 10 VDC.

F5-10	AO1 zero offset coefficient	Default	0.0%
	Setting Range	-100.0% to +100.0%	
F5-11	AO1 gain	Default	1.00
	Setting Range	-10.00 to +10.00	
F5-12	AO2 zero offset coefficient	Default	0.00%
	Setting Range	-100.0% to +100.0%	
F5-13	AO2 gain	Default	1.00
	Setting Range	-10.00 to +10.00	

These four function parameters can define required AO curve.

If "b" represents zero offset, "k" represents gain, "Y" represents actual output of the AO, and "X" represents output frequency, then the actual output is

$$Y=kX + b.$$

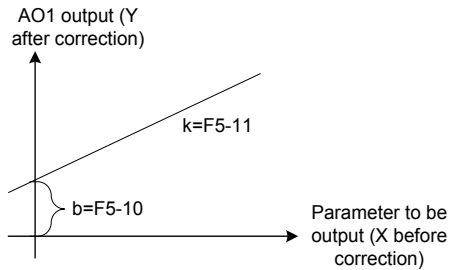

Figure 5-10 AO signal correction characteristic curve

Zero offset coefficient 100% of AO1 and AO2 corresponds to 10 V or 20 mA. A standard output is the value corresponding to 0 to 10 V or 0 to 20 mA without offset or gain.

For example, AO is used for output of frequency reference. To implement output of 8 V at 0 Hz and output of 4 V at 40 Hz, set F5-11 to -0.5 and set F5-10 to 80%.

5.10 Auto-tuning

You can obtain parameters of controlled motor through motor auto-tuning. Motor auto-tuning methods are dynamic auto-tuning, and static auto-tuning with load. You can enter the motor parameters manually.

Auto-tuning Method	Application	Result
Dynamic auto-tuning with no-load F1-37 = 12	It is applied to applications where motor can be disconnected from load.	Best
Auto-tuning with load F1-37 = 11	It is applied to applications where the motor cannot be disconnected from the load and dynamic auto-tuning is not allowed.	OK
Manual parameter input	It is applied to applications where the motor cannot be disconnected from the load. Copy parameters of motors of same model which have been auto-tuned to F1-16 to F1-20.0	Better

Auto-tuning methods are described below.

Motor 1 is used to describe motor auto-tuning methods. If you need to perform motor 2 auto-tuning, set F0-24=1.

Step 1: If the motor can be disconnected from load, cut off the power, disconnect the motor from load to let the load runs in idle.

Step 2: Power on the AC drive. Set F0-02 = 0 to select the operating panel as running command.

Step 3: Input motor nameplate parameters (F1-00 to F1-05) correctly. Set the following parameters according to the motor:

Motor	Parameter
Motor 1	F1-00: Motor type selection F1-01: Rated motor power F1-02: Rated motor voltage F1-03: Rated motor current F1-04: Rated motor frequency F1-05: Rated motor speed
Motor 2	A2-00 to A2-05 have the same definition.

If there is an encoder, set F1-27 and F1-28.

Step 4: Set F1-37 (A2-37 in case of Motor 2) to 12 (complete dynamic auto-tuning) and press ENTER. TUNE is displayed, as shown in the following figure:



5

Press RUN on the operating panel. The AC drive drives the motor to accelerate/decelerate and run in forward/reverse direction. The RUN indicators becomes ON and auto-tuning lasts for about 2 minutes. After the preceding display disappears and the operating panel returns to normal parameter display state, it indicates that auto-tuning is completed.

After auto-tuning, the following motor parameters are calculated:

Motor	Parameter
Motor 1	F1-16: Stator resistance of synchronous motor F1-17: D-axis inductance of synchronous motor F1-18: Q-axis inductance of synchronous motor F1-20: Counter electromotive force of synchronous motor
Motor 2	A2-16 to A2-20 have the same definition.

If motor cannot be disconnected from load, set F1-37 (A2-37 in case of Motor 2) to 11 (auto-tuning of synchronous motor with load) and press RUN on the operating panel. Auto-tuning starts.

6 Troubleshooting and Solutions

6.1 Safety Information

Safety Information



Danger

- ◆ Do not disconnect the AC drive while power is on, and keep all breakers in OFF state. Failure to comply may result in electric shock.



Warning

- ◆ Make sure to ground the AC drive according to local laws and regulations. Failure to comply may result in electric shock or a fire.
- ◆ Do not remove the front cover or touch internal circuit while the power is on. Failure to comply may result in electric shock.
- ◆ Do not allow unqualified personnel to perform any maintenance, inspection or part replacement work. Failure to comply may result in electric shock or a fire.
- ◆ When installing the drive inside an enclosed cabinet, use cooling fan or air conditioner to keep temperature below 50°C. Failure to comply may result in overheating or even a fire.
- ◆ Tighten all screws based on the specified tightening torque. Failure to comply may result in a fire or electric shock.
- ◆ Always confirm input voltage is within nameplate rating. Failure to comply may result in electric shock or a fire.
- ◆ Keep flammable and combustible materials away from the drive.



Caution

- ◆ Cover the top of the drive with a temporary cloth or paper during installation so as to prevent foreign matter such as metal shavings, oil and water from falling into the drive. If any foreign matter falls into the drive, the drive may have a fault.
- ◆ After the installation is completed, remove the temporary cloth or paper. If leaving the cloth or paper on the drive, the drive may have abnormal heating due to poor ventilation.
- ◆ Follow proper electrostatic discharge (ESD) procedures when operating the AC drive. Failure to comply will damage internal circuit of the drive.

6.2 Troubleshooting During Trial Run

1. Drive in Open-loop Vector Control (F0-01 = 0: Default value)

The AC drive implements control of the motor speed and torque without an encoder for speed feedback. In this control mode, auto-tuning is required for motor related parameters.

Problem	Solutions
Overload or overcurrent detected during motor start	<ul style="list-style-type: none"> Set motor parameters F1-01 to F1-05 according to motor nameplate. Select a proper motor auto-tuning mode by setting F1-37 and perform motor auto-tuning. If possible, select dynamic auto-tuning.
Poor torque or speed response and motor oscillation at speeds below 5 Hz	<ul style="list-style-type: none"> If motor torque and speed response are too slow, increase the setting of F2-00 (speed loop proportional gain) by 10 gradually or decrease the setting of F2-01 (speed loop integral time) by 0.05 gradually. If motor oscillation occurs, decrease F2-00 and increase F2-01.
Poor torque or speed response and motor oscillation at speeds above 5 Hz	<ul style="list-style-type: none"> If motor torque and speed response are too slow, increase the setting of F2-03 (speed loop proportional gain) by 10 gradually or decrease the setting of F2-04 (speed loop integral time) by 0.05 gradually. If motor oscillation occurs, decrease F2-03 and increase F2-04.
Obvious speed fluctuation	<ul style="list-style-type: none"> If motor speed fluctuation is abnormal, decrease F2-00 or F2-03.
Too loud motor noise	<ul style="list-style-type: none"> Increase the setting of F0-15 (carrier frequency) by 1.0 kHz gradually. Note that increase in carrier frequency will result in an increase in the leakage current of the motor.
Insufficient motor torque	<ul style="list-style-type: none"> Check whether torque upper limit is small. If yes, please: Increase the setting of F2-10 (digital setting of torque upper limit in speed control mode) in the speed control mode; increase the torque reference (A0-03) in the torque control mode.

2. Drive in Feedback Vector Control (F0-01 = 1)

It is applicable to the application with an encoder for speed feedback. In this mode, you need to set the encoder pulses per revolution, the encoder type and the encoder direction correctly.

Problem	Solutions
Overload or overcurrent fault detected during motor start	<ul style="list-style-type: none"> Set F1-27, F1-28 and F1-30 correctly.
Overload or overcurrent detected during motor running	<ul style="list-style-type: none"> Set motor parameters F1-01 to F1-05 according to motor nameplate. Select a proper motor auto-tuning mode by setting F1-37 and perform motor auto-tuning. If possible, select dynamic auto-tuning.
Poor torque or speed response and motor oscillation at speeds below 5 Hz	<ul style="list-style-type: none"> If motor torque and speed response are too slow, increase the setting of F2-00 (speed loop proportional gain) by 10 gradually or decrease the setting of F2-01 (speed loop integral time) by 0.05 gradually. If motor oscillation occurs, decrease F2-00 and increase F2-01.
Poor torque or speed response and motor oscillation at speeds above 5 Hz	<ul style="list-style-type: none"> If motor torque and speed response are too slow, increase the setting of F2-03 (speed loop proportional gain) by 10 gradually or decrease the setting of F2-04 (speed loop integral time) by 0.05 gradually. If motor oscillation occurs, decrease F2-03 and increase F2-04.
Obvious speed fluctuation	<ul style="list-style-type: none"> If motor speed fluctuation is abnormal, decrease F2-00 or F2-01.
Too loud motor noise	<ul style="list-style-type: none"> Increase the setting of F0-15 (carrier frequency) by 1.0 kHz gradually. Note that increase in carrier frequency will result in an increase in the leakage current of the motor.
Insufficient motor torque	<ul style="list-style-type: none"> Check whether torque upper limit is small. If yes, please: Increase the setting of F2-10 (digital setting of torque upper limit in speed control mode) in the speed control mode; increase the torque reference (A0-03) in the torque control mode.

6.3 Fault Display

When a fault occurs during running, the AC drive stops output immediately, the fault indicator **TUNE/TC** flashes, and the contact of the fault relay acts. The operation panel displays the fault code such as **Err02**, as shown in the following figure. Solutions in the table are for reference only. Do not repair or transform the drive by yourself. If the fault persists, contact Inovance or our agent for technical support.

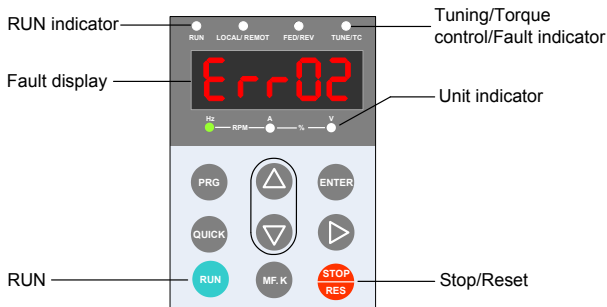

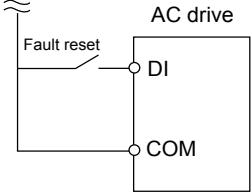

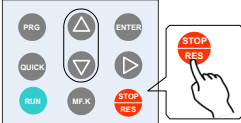
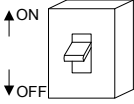
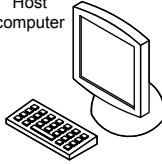



Figure 6-1 Interface

6.4 Resetting Fault

Stage	Solution	Remark
After the fault occurs	Check the operating panel for detailed information of recent three faults, such as fault type and frequency, current, bus voltage, DI/DO state, accumulative power-on time and accumulative running time at occurrence of the faults.	View these information via F9-14 to F9-44. 
Before the fault is reset	Find and remove cause of the fault according to the fault type displayed on the operating panel. Then reset the fault.	Troubleshoot the fault according to section 6.5 "Faults and Diagnostics".
Fault resetting method	(1) Allocate a DI terminal with function 9 "Fault reset (RESET)" by setting any of F4-00 to F4-09 to 9.	
	(2) Confirm that F7-02 = 1 (default value). Then press the  key on operating panel.	Fault resetting via operating panel 
	(3) Disconnect the power supply. Until the fault code disappears, connect the power supply again.	
	(4) Fault resetting via host computer Confirm that F0-02 = 2 and write "7" (fault reset) to communication address 2000H. <small><Note></small>	Host computer 
<p>Note</p>	<ul style="list-style-type: none"> For details, refer to "Appendix B Definition of Communication Data Address and Modbus Communication Protocol". 	

6.5 Faults and Diagnostics

Troubleshoot the faults occurring during operating the drive as follows:

Fault Name	Operating Panel Display	Cause	Possible Solution
Overcurrent during acceleration		Ground fault or short circuit exists in the output circuit.	<ul style="list-style-type: none"> Check whether short-circuit occurs on the motor, motor cable or contactor.
		Control mode is SVC or FVC but motor auto-tuning is not performed.	<ul style="list-style-type: none"> Set motor parameters according to motor nameplate and perform motor auto-tuning.
		Acceleration time is too short.	<ul style="list-style-type: none"> Increase acceleration time.
		The overcurrent stall prevention parameters are set improperly.	<ul style="list-style-type: none"> Ensure that current limit is enabled (F3-19 = 1). The setting of current limit level (F3-18) is too large. Adjust it between 120% and 150%. The setting of current limit gain (F3-20) is too small. Adjust it between 20 and 40.
		Customized torque boost or V/F curve is not appropriate.	<ul style="list-style-type: none"> Adjust the customized torque boost or V/F curve.
		The spinning motor is started.	<ul style="list-style-type: none"> Enable the catching a spinning motor function or start the motor after it stops.
		The AC drive suffers external interference.	<ul style="list-style-type: none"> View historical fault records. If the current value is far from the overcurrent level, find interference source. If external interference does not exist, it is the drive board or hall device problem.
Overcurrent during deceleration		Ground fault or short circuit exists in the output circuit.	<ul style="list-style-type: none"> Check whether short-circuit occurs on the motor, motor cable or contactor.
		Control mode is SVC or FVC but motor auto-tuning is not performed.	<ul style="list-style-type: none"> Set motor parameters according to motor nameplate and perform motor auto-tuning.
		Deceleration time is too short.	<ul style="list-style-type: none"> Increase deceleration time.
		The overcurrent stall prevention parameters are set improperly.	<ul style="list-style-type: none"> Ensure that current limit is enabled (F3-19 = 1). The setting of current limit level (F3-18) is too large. Adjust it between 120% and 150%. The setting of current limit gain (F3-20) is too small. Adjust it between 20 and 40.
		Braking unit and braking resistor are not installed.	<ul style="list-style-type: none"> Install braking unit and braking resistor.
		The AC drive suffers external interference.	<ul style="list-style-type: none"> View historical fault records. If the current value is far from the overcurrent level, find interference source. If external interference does not exist, it is the drive board or hall device problem.

Fault Name	Operating Panel Display	Cause	Possible Solution
Overcurrent at constant speed	Err04	Ground fault or short circuit exists in the output circuit.	<ul style="list-style-type: none"> ● Check whether short-circuit occurs on the motor, motor cable or contactor.
		Control mode is SVC or FVC but motor auto-tuning is not performed.	<ul style="list-style-type: none"> ● Set motor parameters according to motor nameplate and perform motor auto-tuning.
		The overcurrent stall prevention parameters are set improperly.	<ul style="list-style-type: none"> ● Ensure that current limit is enabled (F3-19 = 1). ● The setting of current limit level (F3-18) is too large. Adjust it between 120% and 150%. ● The setting of current limit gain (F3-20) is too small. Adjust it between 20 and 40.
		The AC drive power class is small.	<ul style="list-style-type: none"> ● If output current exceeds rated motor current or rated output current of the AC drive during stable running, replace a drive of larger power class.
		The AC drive suffers external interference.	<ul style="list-style-type: none"> ● View historical fault records. If the current value is far from the overcurrent level, find interference source. If external interference does not exist, it is the drive board or hall device problem.
Overvoltage during acceleration	Err05	Input voltage is too high.	<ul style="list-style-type: none"> ● Adjust input voltage to normal range.
		An external force drives motor during acceleration.	<ul style="list-style-type: none"> ● Cancel the external force or install a braking resistor.
		The overvoltage stall prevention parameters are set improperly.	<ul style="list-style-type: none"> ● Ensure that the voltage limit function is enabled (F3-23 = 1). ● The setting of voltage limit (F3-22) is too large. Adjust it between 770 V and 700 V. ● The setting of frequency gain for voltage limit (F3-24) is too small. Adjust it between 30 and 50.
		Braking unit and braking resistor are not installed.	<ul style="list-style-type: none"> ● Install braking unit and braking resistor.
		Acceleration time is too short.	<ul style="list-style-type: none"> ● Increase acceleration time.
Overvoltage during deceleration	Err06	The overvoltage stall prevention parameters are set improperly.	<ul style="list-style-type: none"> ● Ensure that the voltage limit function is enabled (F3-23 = 1). ● The setting of voltage limit (F3-22) is too large. Adjust it between 770 V and 700 V. ● The setting of frequency gain for voltage limit (F3-24) is too small. Adjust it between 30 and 50.
		An external force drives motor during deceleration.	<ul style="list-style-type: none"> ● Cancel the external force or install a braking resistor.
		Deceleration time is too short.	<ul style="list-style-type: none"> ● Increase deceleration time.
		Braking unit and braking resistor are not installed.	<ul style="list-style-type: none"> ● Install braking unit and braking resistor.

Fault Name	Operating Panel Display	Cause	Possible Solution
Overvoltage at constant speed	Err07	The overvoltage stall prevention parameters are set improperly.	<ul style="list-style-type: none"> Ensure that the voltage limit function is enabled (F3-23 = 1). The setting of voltage limit (F3-22) is too large. Adjust it between 770 V and 700 V. The setting of frequency gain for voltage limit (F3-24) is too small. Adjust it between 30 and 50. The setting of frequency rise threshold during voltage limit (F3-26) is too small. Adjust it between 5 Hz and 20 Hz.
		An external force drives motor during running.	<ul style="list-style-type: none"> Cancel the external force or install a braking resistor.
Control power fault	Err08	The input voltage exceeds the setting range.	<ul style="list-style-type: none"> Adjust the input voltage to be within the setting range.
Undervoltage	Err09	Instantaneous power failure occurs	<ul style="list-style-type: none"> Enable the power dip ride through function (F9-59 ≠ 0).
		The AC drive's input voltage is not within the permissible range.	<ul style="list-style-type: none"> Adjust the voltage to normal range.
		The bus voltage is abnormal.	<ul style="list-style-type: none"> Contact the agent or Inovance.
		The rectifier bridge, the buffer resistor, the drive board or the control board are abnormal.	<ul style="list-style-type: none"> Contact the agent or Inovance.
AC drive overload	Err10	Load is too heavy or locked-rotor occurs on motor.	<ul style="list-style-type: none"> Reduce load or check motor and mechanical conditions.
		The AC drive power class is small.	<ul style="list-style-type: none"> Replace a drive of larger power class.
Motor overload	Err11	F9-01 (Motor overload protection gain) is set improperly.	<ul style="list-style-type: none"> Set F9-01 correctly.
		Load is too heavy or locked-rotor occurs on motor.	<ul style="list-style-type: none"> Reduce load or check motor and mechanical conditions.
Input phase loss	Err12	Input phase loss occurs.	<ul style="list-style-type: none"> Eliminate faults in external circuitry.
		Drive board, lightning protection board, control board, or rectifier bridge is abnormal.	<ul style="list-style-type: none"> Contact the agent or Inovance.
Output phase loss	Err13	Motor winding is damaged.	<ul style="list-style-type: none"> Check resistance between motor wires.
		The cable connecting the AC drive and the motor is abnormal.	<ul style="list-style-type: none"> Check for wiring errors and ensure the output cable is connected properly.
		The AC drive's three-phase outputs are unbalanced when the motor is running.	<ul style="list-style-type: none"> Check whether the motor three-phase winding is normal.
		The drive board or the IGBT is abnormal.	<ul style="list-style-type: none"> Contact the agent or Inovance.





Fault Name	Operating Panel Display	Cause	Possible Solution
IGBT overheat	Err 14	The ambient temperature is too high.	<ul style="list-style-type: none"> Lower the ambient temperature.
		The ventilation is clogged.	<ul style="list-style-type: none"> Clean the ventilation.
		The fan is damaged.	<ul style="list-style-type: none"> Replace the cooling fan.
		Thermally sensitive resistor of IGBT is damaged.	<ul style="list-style-type: none"> Replace the damaged thermally sensitive resistor.
		The AC Drive IGBT is damaged.	<ul style="list-style-type: none"> Replace the AC Drive IGBT.
External fault	Err 15	External fault signal is input via DI.	<ul style="list-style-type: none"> Confirm that the mechanical condition allows restart (F8-18) and reset the operation.
		External fault signal is input via virtual I/O.	<ul style="list-style-type: none"> Confirm that the virtual I/O parameters in group A1 are set correctly and reset the operation.
Communication fault	Err 16	Host computer is in abnormal state.	<ul style="list-style-type: none"> Check the cable of host computer.
		Communication cable is abnormal.	<ul style="list-style-type: none"> Check the communication cables.
		The serial port communication protocol (F0-28) of extension communication card is set improperly.	<ul style="list-style-type: none"> Set F0-28 of extension communication card correctly.
		Communication parameters in group Fd are set improperly.	<ul style="list-style-type: none"> Set communication parameters in group Fd properly.
		After all the preceding checkings are done but the fault still exists, restore the default settings.	
Contactor fault	Err 17	Drive board and power supply are abnormal.	<ul style="list-style-type: none"> Replace drive board or power supply board.
		Contactor is abnormal.	<ul style="list-style-type: none"> Replace contactor.
		The lightning protection board is abnormal.	<ul style="list-style-type: none"> Replace the lightning protection board.
Current detection fault	Err 18	The hall is abnormal.	<ul style="list-style-type: none"> Replace the hall element.
		The drive board is abnormal.	<ul style="list-style-type: none"> Replace the drive board.
Motor auto-tuning fault	Err 19	Motor parameters are not set according to nameplate.	<ul style="list-style-type: none"> Set motor parameters correctly according to nameplate.
		Motor auto-tuning times out.	<ul style="list-style-type: none"> Check the cable connecting AC drive and motor.
		The encoder is abnormal.	<ul style="list-style-type: none"> Check whether F1-27 (encoder pulses per revolution) is set correctly. Check whether signal lines of encoder are connected correctly and securely.
Encoder fault	Err 20	Encoder is not matched.	<ul style="list-style-type: none"> Set the type of encoder correctly.
		Encoder wiring is incorrect.	<ul style="list-style-type: none"> Check the PG card power supply and phase sequence.
		Encoder is damaged.	<ul style="list-style-type: none"> Replace encoder.
		PG card is abnormal.	<ul style="list-style-type: none"> Replace PG card.
EEPROM read-write fault	Err 21	The EEPROM chip is damaged.	<ul style="list-style-type: none"> Replace the main control board.
Short circuit to ground	Err 23	Motor is short circuited to the ground.	<ul style="list-style-type: none"> Replace cable or motor.

Fault Name	Operating Panel Display	Cause	Possible Solution
Accumulative running time reached	Err26	Accumulative running time reaches the setting value.	<ul style="list-style-type: none"> Clear the record through parameter initialization.
User-defined Fault 1	Err27	User-defined fault 1 is input via DI.	<ul style="list-style-type: none"> Reset the operation.
		User-defined fault 1 is input via virtual I/O.	<ul style="list-style-type: none"> Reset the operation.
User-defined Fault 2	Err28	User-defined fault 2 is input via DI.	<ul style="list-style-type: none"> Reset the operation.
		User-defined fault 2 is input via virtual I/O.	<ul style="list-style-type: none"> Reset the operation.
Accumulative power-on time reached	Err29	Accumulative power-on time reaches the setting value.	<ul style="list-style-type: none"> Clear the record through parameter initialization.
Load loss	Err30	The output current of AC drive is smaller than F9-64 (load loss detection level).	<ul style="list-style-type: none"> Check whether load is disconnected or the setting of F9-64 and F9-65 (load lost detection time) satisfies actual running condition.
PID feedback lost during running Feedback loss	Err31	PID feedback is smaller than the setting value of FA-26 (detection level of PID feedback loss).	<ul style="list-style-type: none"> Check PID feedback or set FA-26 properly.
Pulse-by-pulse current limit fault	Err40	Load is too heavy or locked-rotor occurs on motor.	<ul style="list-style-type: none"> Reduce load or check motor and mechanical conditions.
		The AC drive power class is small.	<ul style="list-style-type: none"> Replace a drive of larger power class.
Motor switchover fault during running Motor winding is damaged.	Err41	Motor switchover via terminal during drive running of the AC drive.	<ul style="list-style-type: none"> Perform motor switchover after the AC drive stops.
Speed error	Err42	Encoder parameters are set improperly.	<ul style="list-style-type: none"> Set encoder parameters properly.
		Motor auto-tuning is not performed.	<ul style="list-style-type: none"> Perform motor auto-tuning.
		F9-69 (detection level of speed error) and F9-70 (detection time of speed error) are set incorrectly.	<ul style="list-style-type: none"> Set F9-69 and F9-70 correctly based on actual condition.
Motor overspeed Problem	Err43	Encoder parameters are set improperly.	<ul style="list-style-type: none"> Set encoder parameters properly.
		Motor auto-tuning is not performed.	<ul style="list-style-type: none"> Perform motor auto-tuning.
		F9-67 (Overspeed detection level) and F9-68 (Overspeed detection time) are set incorrectly.	<ul style="list-style-type: none"> F9-67 and F9-68 correctly based on actual condition.
Motor overtemperature	Err45	Cable connection of temperature sensor becomes loose	<ul style="list-style-type: none"> Check cable connection of temperature sensor.
		The motor temperature is too high.	<ul style="list-style-type: none"> Decrease carrier frequency or take other measures to cool the motor.

6 Troubleshooting and Solutions

Fault Name	Operating Panel Display	Cause	Possible Solution
Initial position angle identification fault	Err51	AC drive output phase loss	<ul style="list-style-type: none"> Check whether the motor wiring is correct.
		The AC drive current detection fails or the hall is damaged.	<ul style="list-style-type: none"> Check the hall.
		The motor inductance is too large.	<ul style="list-style-type: none"> Set F9-75 to avoid this fault.
Braking unit overload	Err61	Resistance of braking resistor is too small.	<ul style="list-style-type: none"> Replace a braking resistor of larger resistance.
Short-circuit of braking circuit	Err62	Braking module is abnormal.	<ul style="list-style-type: none"> Contact the agent or Inovance.
Counter electromotive force identification exception warning	A64	Related parameters are set incorrectly.	<ul style="list-style-type: none"> Set related parameters correctly, the rated frequency and rotation speed in particular.
		F1-20 is set incorrectly.	<ul style="list-style-type: none"> Check whether F1-20 is set to a too large or too small value.
		Counter electromotive force identification exception during dynamic identification	<ul style="list-style-type: none"> Check whether the motor has no load during dynamic identification and whether the motor rotates at 40% of the rated rotation speed. If the motor has load and its speed is below 40% of the rated rotation speed, perform identification again after disconnecting the motor from load.
		The motor is demagnetized.	<ul style="list-style-type: none"> Check whether the motor is demagnetized.
		Counter electromotive force is too large or too small.	<ul style="list-style-type: none"> If yes, press STOP to reset the warning and the motor continues to run.

6.6 Symptoms and Diagnostics

SN	Fault Description	Cause	Possible Solution
1	There is no display while power-on. 	The mains voltage is not input or too low.	<ul style="list-style-type: none"> Check the power supply.
		The switching power supply on drive board of the AC drive is faulty.	<ul style="list-style-type: none"> Check bus voltage.
		Wires between control board and drive board and between control board and operating panel break.	<ul style="list-style-type: none"> Re-connect the 8-pin wire and 40-pin wire.
		Pre-charge resistor of the AC drive is damaged.	<ul style="list-style-type: none"> Contact the agent or Inovance.
		Control board or operating panel is faulty.	
Rectifier bridge is damaged.			
2	"HC" is displayed while power-on. 	Wire between drive board and control board is in poor contact.	<ul style="list-style-type: none"> Re-connect the 8-pin wire and 28-pin wire.
		Related components on control board are damaged	<ul style="list-style-type: none"> Contact the agent or Inovance.
		The motor or motor cable is short circuited to ground.	
		The hall is damaged.	
The mains voltage is too low.			
3	"Err23" is displayed at power-on. 	Motor or motor output cable is short circuited to ground.	<ul style="list-style-type: none"> Use a megger to measure insulation resistance of motor and motor cable.
		The AC drive is damaged.	<ul style="list-style-type: none"> Contact the agent or Inovance.
4	The display is normal while power-on. But after running, "HC" is displayed and the drive stops immediately. 	The cooling fan is damaged or locked-rotor occurs.	<ul style="list-style-type: none"> Replace the cooling fan.
		Short circuit exists in wiring of control terminals.	<ul style="list-style-type: none"> Eliminate short circuit fault in control circuit wiring.
5	Err14 (IGBT overheat) is detected frequently. 	The setting of carrier frequency is too high.	<ul style="list-style-type: none"> Reduce carrier frequency (F0-15).
		The cooling fan is damaged, or ventilation is clogged.	<ul style="list-style-type: none"> Replace the fan or clean the ventilation.
		Components inside the AC drive are damaged (thermistor or others).	<ul style="list-style-type: none"> Contact the agent or Inovance.

6 Troubleshooting and Solutions

SN	Fault Description	Cause	Possible Solution
6	The motor does not rotate after the AC drive runs.	It is motor or motor cable problem.	<ul style="list-style-type: none"> Check that wiring between AC drive and motor is normal.
		Related AC drive and motor parameters are set improperly.	<ul style="list-style-type: none"> Restore the factory parameters and re-set the following parameters properly: Encoder parameters, Motor ratings, such as rate motor frequency and rated motor speed Motor 1 control mode (F0-01) and command source selection (F0-02) F3-01 (torque boost) in V/F control under heavy-load start.
		Cable connection between drive board and control board is in poor contact.	<ul style="list-style-type: none"> Re-connect wirings and ensure secure connection.
		The drive board is faulty.	<ul style="list-style-type: none"> Contact the agent or Inovance.
7	DI terminals are disabled.	Related parameters are set incorrectly.	<ul style="list-style-type: none"> Check and set parameters in group F4 again.
		External signals are incorrect.	<ul style="list-style-type: none"> Re-connect external signal cables.
		Jumper across OP and +24 V becomes loose.	<ul style="list-style-type: none"> Re-confirm the jumper bar across OP and +24 V.
		The control board is faulty.	<ul style="list-style-type: none"> Contact the agent or Inovance.
8	Motor speed does not rise in closed-loop vector control.	Encoder fault	<ul style="list-style-type: none"> Replace encoder and re-confirm cable connection.
		Encoder connection is incorrect or in poor contact.	<ul style="list-style-type: none"> Replace PG card.
		PG card is faulty. The drive board is faulty.	<ul style="list-style-type: none"> Contact the agent or Inovance.
9	The AC drive detects overcurrent and overvoltage frequently.	Motor parameters are set improperly.	<ul style="list-style-type: none"> Set motor parameters or perform motor auto-tuning again.
		Acceleration/deceleration time is improper.	<ul style="list-style-type: none"> Set proper acceleration/deceleration time.
		Load fluctuates.	<ul style="list-style-type: none"> Contact the agent or Inovance.
10	Err17 is detected upon power-on or running. 	The pre-charge relay or contactor is not closed.	<ul style="list-style-type: none"> Check whether the relay or contactor cable is loose. Check whether the relay or contactor is faulty. Check whether 24 V power supply of the contactor is faulty. Contact the agent or Inovance.
11	The motor stops freely or cannot be braked during deceleration or deceleration to stop.	The encoder disconnection or overvoltage stall protection takes effect.	<ul style="list-style-type: none"> When F0-01 = 1, check whether the encoder is connected. If braking resistor is set, set Overvoltage Stall Enabled to Disabled (F3-23 = 0).

7 Routine Inspection and Maintenance

7.1 Routine Inspection

Safety Information



Danger

- ◆ Do not connect or disconnect wiring while the power is on.
- ◆ Before the inspection, disconnect all power supply. After disconnect the power of the drive, as there is residual voltage in the DC capacitor in the drive, wait for several minutes until the the power indicator is off. Before powering on the drive again for operation, wait for an interval specified by the drive.
- ◆ Do not modify or disconnect wiring, remove optional extension card or replace the cooling fan while the power is on.
- ◆ Make sure to connect the motor-side grounding terminal. Failure to comply may result in electric shock due to touching motor housing.
- ◆ Do not allow unqualified personnel to do the repair & maintenance work.
- ◆ Installation, wiring, commissioning, repair & maintenance, and component replacement must be performed only by qualified technicians.



Warning

- ◆ Do not run the AC drive with front cover removed.
- ◆ Drawings in the manual are sometimes shown without covers or protective guards to display the details. Remember to install the covers or protective guards as specified first, and then perform operations in accordance with instructions.
- ◆ Tighten all terminal screws based on specified tightening torque.
- ◆ Ensure that input voltage is within permissible range. Incorrect input voltage of main circuit may result in abnormal running.
- ◆ Keep combustible materials far away from the AC drive or mount the AC drive on incombustible surfaces such as a metal wall.



Caution

- ◆ Replace the cooling fan in correct ways as specified in this chapter. Ensure correct air outlet direction of the fan. Incorrect air direction will diminish the cooling effects.
- ◆ Do not connect or disconnect motor while the drive is running. Failure to comply may result in electric shock and damage to the AC drive.
- ◆ Use shielded cables for control circuit wiring.
- ◆ Meanwhile, ground the shield to the grounding terminal reliably.
- ◆ Do not modify the drive circuitry. Failure to comply will damage the AC drive.
- ◆ Make sure to connect the output terminals of the AC drive and the motor terminals correctly.
- ◆ If it is necessary to change the motor rotation direction, exchange any two of UVW cables of the AC drive.
- ◆ Do not operate the AC drive that has been damaged. This is to prevent further damage to external equipments.

7.1.1 Routine Inspection Items

Influence of ambient temperature, humidity, dust and vibration will cause aging of components in the AC drive, which may cause potential faults or reduce the product life. Therefore, it is necessary to carry out routine and periodic maintenance. More frequent inspection will be required if it is used in harsh environments, such as:

- High ambient temperature;
- Frequent starting and stopping;
- Fluctuations in the AC power supply or load;
- Excessive vibrations or shock loading;
- Dust, metal dust, salt, sulfuric acid, chlorine atmospheres;
- Poor storage conditions.

Check the following items routine to avoid deterioration in performance or product. Copy this checklist and sign the "Checked" column after each inspection.

Inspection Item	Inspection Points	Solutions	Checked
Motor	Inspect whether abnormal oscillation or noise exists.	<ul style="list-style-type: none"> ● Check mechanical connections. ● Check power phases of the motor. ● Tighten all loose screws. 	
Fan	Inspect whether the cooling fan of the AC drive and the motor works abnormally.	<ul style="list-style-type: none"> ● Check running of the drive-side cooling fan. ● Check running of the motor-side cooling fan. ● Check whether the cooling fan is clogged or dirty. ● Check whether ambient temperature is within the permissible range. 	
Installation environment	Inspect whether the cabinet and cable duct are abnormal.	<ul style="list-style-type: none"> ● Check for input and output cables with insulation damaged. ● Check for vibration of hanging bracket. ● Check whether copper ground bars and terminals become loose or get corroded. 	
Load	Inspect whether the drive output current exceeds the drive or motor rating for an extended period of time.	<ul style="list-style-type: none"> ● Check for setting of motor parameters. ● Check for excessive load. ● Check for mechanical vibration (< 0.6 g on normal condition). 	
Input voltage	Check main power supply and control voltage.	<ul style="list-style-type: none"> ● Adjust the input voltage to the permissible range. ● Check whether start of heavy load exists. 	

7.2 Periodic Inspection

7.2.1 Periodical Inspection Items

Always keep the AC drive clean. Clear away dusts especially metal powder on the surface of the AC drive, to prevent dust from entering the drive. Clear oil dirt from the cooling fan of the AC drive.



Danger

- ◆ Do not perform inspection work while the power is on.
- ◆ Before the inspection, disconnect all power supply and wait for 10 minutes to avoid risk caused by the residual voltage in the capacitor of the drive.

Inspection Item	Inspection Points	Inspection Points	Checked
General	Inspect for wastes, dirt and dust on the surface of the AC drive.	<ul style="list-style-type: none"> • Check whether the AC drive is powered off. • Use a vacuum cleaner to suck up wastes and dust to prevent direct touching. • Wipe surface dirt gently with a soft cloth immersed in neutral detergent. 	
Cables	Inspect power cables and connections for discoloration. Inspect wiring insulation for aging or wear.	<ul style="list-style-type: none"> • Replace cracked cable. • Replace damaged terminals. 	
Peripheral devices such as relay and contactor	Inspect contactors and relays for excessive noise during operation. Inspect coils for signs of overheating such as melted or cracked insulation. Check whether the coil voltage is normal.	<ul style="list-style-type: none"> • Replace abnormal peripheral device. 	
Ventilation	Inspect whether ventilation and heatsink are clogged. Check whether the fan is damaged.	<ul style="list-style-type: none"> • Clean ventilation. • Replace the fan. 	
Control circuit	Inspect for control components in poor contact. Inspect for loose terminal screws. Inspect for control cables with cracked insulation.	<ul style="list-style-type: none"> • Clear away foreign matters on the surface of control cables and terminals. • Replace damaged or corroded control cables. 	

7.2.2 Insulation Test on Main Circuit

Before measuring insulation resistance with a megameter (a 500 VDC megameter is recommended), disconnect the main circuit from the AC drive. Do not conduct the dielectric strength test using an insulation megameter. High voltage (> 500 V) test need not be performed again because it has been completed before delivery.

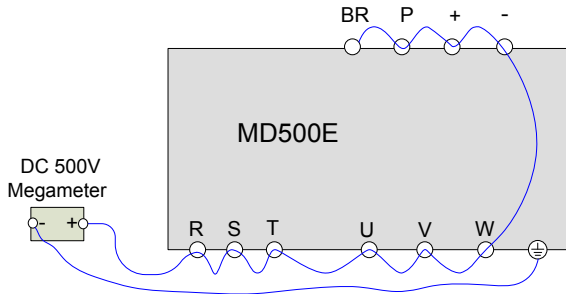

Figure 7-1 Test insulation on the main circuit

The measured insulation resistance must be greater than 5 MΩ.

Before test, remove the VDR screw. For positions of VDR and EMC screws, refer to Figure 3-37 in 3 Installation and Wiring.

7.3 Replacement of Wear Parts

7.3.1 Lifetime of Wear Parts

The lifetime of fans and electrolytic DC bus capacitors is related to the operating environment and maintenance status. Generally, the lifetime is shown as follows:

Component	Service Life ^{<Note>}
Fan	≥ 5 years
Electrolytic capacitor	≥ 5 years

Note:

You can determine when to replace these parts according to the actual operating time.

- Ambient temperature: 40°C
- Load rate: 80%
- Operating rate: 24 hours per day

7.3.2 Number of Fans on the Drive

Model	Number of Fans
Three-phase 380 to 480 V, 50/60 Hz	
MD500ET0.4GB	/
MD500ET0.7GB	/
MD500ET1.1GB	/
MD500ET1.5GB	1
MD500ET2.2GB	1
MD500ET3.0GB	1
MD500ET3.7GB	1
MD500ET5.5GB	1
MD500ET7.5GB	1
MD500ET11GB	2
MD500ET15GB	2
MD500ET18.5G(B)(-T)	1
MD500ET22G(B)(-T)	1
MD500ET30G(B)	1
MD500ET37G(B)	1
MD500ET45G(B)	1
MD500ET55G(B)	1
MD500ET75G(B)	2
MD500ET90G	2
MD500ET110G	2
MD500ET132G	2
MD500ET160G	2
MD500ET200G(-L)	2
MD500ET220G(-L)	2
MD500ET250G(-L)	3
MD500ET280G(-L)	3
MD500ET315G(-L)	3
MD500ET355G(-L)	3
MD500ET400G(-L)	3
MD500ET450G(-L)	3

7.3.3 Replacement of Fans

1. **Possible causes of damage: bearing worn and blade aging**
2. **Judging criteria: Whether there is crack on the blade; whether there is abnormal vibration noise upon startup; and whether the blade runs normally.**
3. **Replacement method:**
 - Decompress the fan cover hook and put the cover out
 - Keep air flow direction upward.

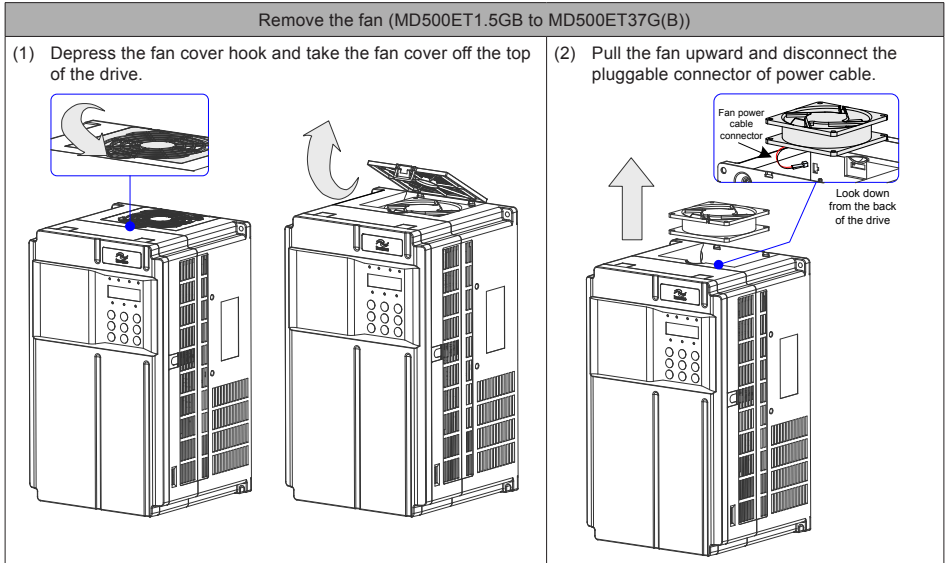

Install the fan (MD500ET1.5GB to MD500ET37G(B))

- (1) Install the fan in reverse order. Pay attention to the correct air flow direction.
- (2) Plug the fan power cable to the socket, as shown in the following figure.

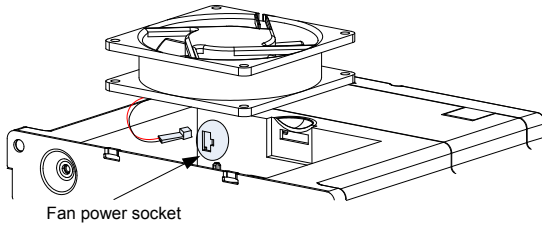

- (3) Install the fan into the drive and ensure that the four mounting pins are aligned.

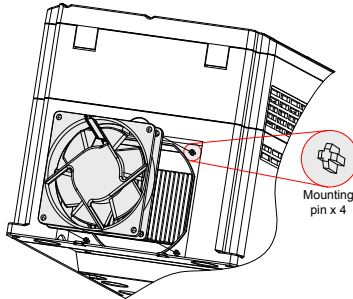

- (4) Insert the two guide pins into the square holes and then press in the hook.

Hook

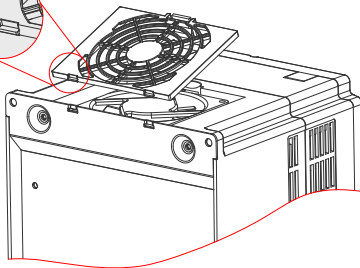

Keep air flow direction upward

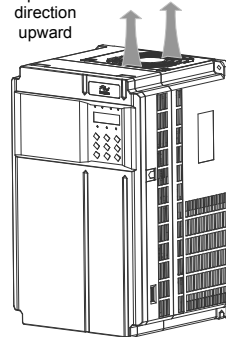

Remove the fan (MD500ET45G(B) to MD500ET160G)

- (1) Disconnect the fan cable from the drive (top view).

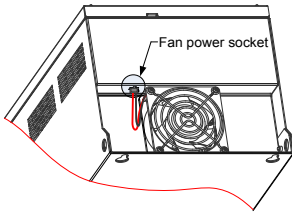

- (2) Remove the four screws from the drive.

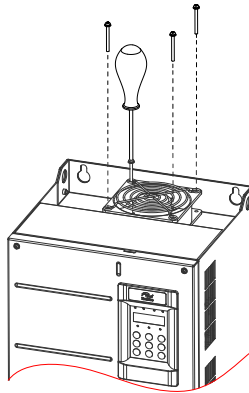

- (3) Remove the fan and fan cover from the drive.

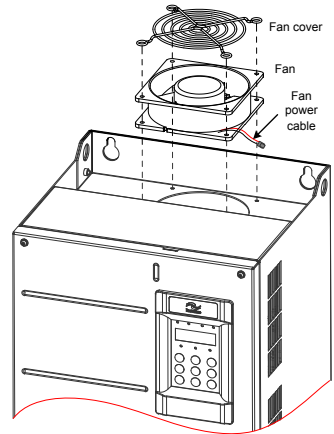

Install the fan (MD500ET45G(B) to MD500ET160G))

- (1) Install the fan in reverse order. Pay attention to the correct air flow direction.
- (2) Install the fan cover and fan into the drive and ensure that the four mounting pins are aligned, as shown by imaginary lines in Figure ③.
- (3) Keep air flow direction upward.

Keep air flow
direction
upward

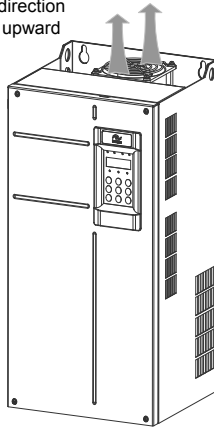

Remove the fan (MD500ET200G to MD500ET450G)

- (1) Disconnect the six screws and remove the front cover.

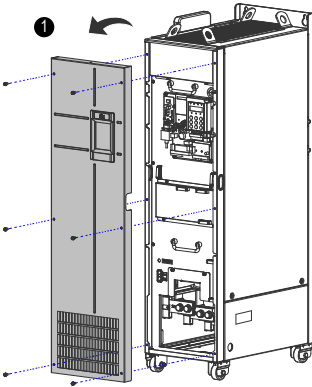

- (2) Disconnect the fan power cable connector from the drive. Each fan has a power cable connector.

- (3) Remove three screws from the fan box and draw the fan box out in the direction of arrow.

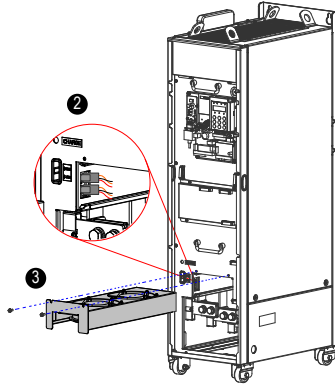

- (4) Loosen four screws from each fan cover and remove the fan.

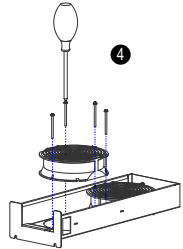

Install the fan (MD500ET200G to MD500ET450G)

- (1) Install the fan in reverse order. Pay attention to the correct air flow direction.
- (2) Align the fan box to the rail and push it into the drive.
- (3) Connect the fan power cable connectors first before fixing the fan cover. After replacement is completed, check that the air flow direction is upright.

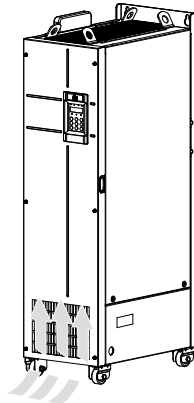

7.3.4 DC Bus Electrolytic Capacitors

1. Possible causes of damage: input power supply in poor quality; high ambient temperature; frequent load jumping; and electrolytic aging.
2. Judging criteria: Whether there is liquid leakage; whether the sage valve has projected; measure the static capacitance; and measure the insulation resistance.
3. Replacement of Electrolytic Capacitor: as the replacement concerns the internal components of the drive, contact the agent or Inovance to perform the replacement.

7.4 Storage

For storage of the AC drive, pay attention to the following three aspects:

1. Pack the AC drive with original packing box provided by Inovance.
2. Do not expose the AC drive to moisture, high temperature or outdoor direct sunlight for a long time.
3. The electrolytic capacitor will deteriorate after being stored for a long time. Thus, the AC drive must be switched on once every 6 months, each time lasting at least 5 hours. Ensure to increase the input voltage gradually to rated value by using a voltage regulator.

7.5 Warranty

Free warranty only applies to the AC drive itself.

Inovance will provide 18-month warranty from date of manufacturing for the failure or damage under normal use conditions. If the equipment has been used for over 18 months, reasonable repair expenses will be charged.

Reasonable repair fee will be charged for the damages due to the following causes in 18 months:

1. Improper operation without following the instructions
2. Fire, flood or abnormal voltage.
3. Using the AC drive for non-recommended function
4. Using the AC drive for non-recommended function
5. Damage cause by force majeure, such as natural disaster, earthquake and lightning stroke

The maintenance fee is charged according to Inovance's uniform standard. If there is an agreement, the agreement prevails.

For warranty details, refer to the Product Warranty Card.

8 Specifications and Model Selection

8.1 Technical Specifications of MD500E Series AC Drive

Table 8-1 Model and technical data

Item		Specification														
MD500ETXXG(B)		0.4	0.7	1.1	1.5	2.2	3.0	3.7	5.5	7.5	11	15	18.5	22	30	37
Applicable motor capacity (kW)		0.4	0.75	1.1	1.5	2.2	3.0	3.7	5.5	7.5	11	15	18.5	22	30	37
Inputs	Rated input current(A)	1.8	2.4	3.7	4.6	6.3	9.0	11.4	16.7	21.9	32.2	41.3	49.5	59	57	69
Outputs	Rated output current(A)	1.5	2.1	3.1	3.8	5.1	7.2	9.0	13.0	17.0	25.0	32.0	37	45	60	75
	Output voltage	Three-phase 380 to 480 V (proportional to input voltage)														
	Max. output frequency	500 Hz (editable through parameter)														
	Carrier frequency	0.8 to 8.0 kHz (automatically adjusted according to the load characteristics)														
	Overload capacity	150% for 60s														
Power supply	Rated voltage Rated frequency	AC: Three-phase 380 to 480 V, 50/60 Hz														
	Allowed voltage fluctuation	-15% to 10%, AC 323 to 528 V														
	Allowed frequency fluctuation	±5%														
	Power capacity (kVA)	2	2.8	4.1	5	6.7	9.5	12	17.5	22.8	33.4	42.8	45	54	52	63
Thermal design	Thermal Design Power (kW)	0.039	0.046	0.057	0.068	0.081	0.109	0.138	0.201	0.24	0.355	0.454	0.478	0.551	0.694	0.815
	Air flow (CFM)	-	-	-	9	9	9	20	24	30	40	42	51.9	57.4	118.5	118.5

Note

- MD500ET18.5G(B)(-T) to MD500ET22G(B)(-T) and MD500ET18.5G(B) to MD500ET22G(B) have the same technical specifications.

Item		Specification															
MD500ETXXG(B)		45	55	75	90	110	132	160	200	220	250	280	315	355	400	450	
Applicable motor capacity (kW)		45	55	75	90	110	132	160	200	220	250	280	315	355	400	450	
Inputs	Rated input current(A)	89	106	139	164	196	240	287	365	410	441	495	565	617	687	782	
Outputs	Rated output current(A)	91	112	150	176	210	253	304	377	426	465	520	585	650	725	820	
	Output voltage	Three-phase 380 to 480 V (proportional to input voltage)															
	Max. output frequency	500 Hz (editable through parameter)															
	Carrier frequency	0.8 to 8.0kHz				0.8 to 6.0kHz (automatically adjusted according to the load characteristics)											
	Overload capacity	150% for 60s (130% for 60s in MD500ET450G)															
Power supply	Rated voltage Rated frequency	AC: Three-phase 380 to 480 V, 50/60 Hz															
	Allowed voltage fluctuation	-15% to 10%, AC 323 to 528 V															
	Allowed frequency fluctuation	±5%															
	Power capacity (kVA)	81	97	127	150	179	220	263	334	375	404	453	517	565	629	716	
Thermal design	Thermal Design Power (kW)	1.01	1.21	1.57	1.81	2.14	2.85	3.56	4.15	4.55	5.06	5.33	5.69	6.31	6.91	7.54	
	Air flow (CFM)	122.2	122.2	218.6	287.2	354.2	547	627	638.4	722.5	789.4	882	645	860	860	860	

Note

- The rated power is measured at 440 VAC input voltage.

Table 8-2 Technical Specifications of MD500E Series AC Drive

Item	Description	
Input frequency resolution	Digital setting: 0.01 Hz Analog setting: Max. frequency x 0.025%	
Control mode	Sensorless vector control (SVC) Feedback vector control (FVC) Voltage/Frequency (V/F) control	
Startup torque	0.25 Hz/150% (SVC) 0 Hz/180% (FVC)	
Speed range	1:200 (SVC)	1:1000 (FVC)
Speed stability accuracy	±0.5% (SVC)	±0.02% (FVC)
Torque control accuracy	±2% (FVC); ±5% for 5 Hz above (SVC)	
Torque boost	Customized boost 0.1 % to 30.0 %	
V/F curve	Straight-line V/F curve Multi-point V/F curve Square V/F curve Complete V/F separation Half V/F separation	
Ramp mode	Straight-line ramp S-curve ramp Four separate acceleration/deceleration time settings in the range of 0.0s to 6500.0s.	
DC injection braking	DC injection braking frequency: 0 Hz to max. frequency DC injection braking active time: 0.0s to 36.0s. Current level of DC injection braking: 0.0% to 100.0%.	
Jog running	Frequency range of jog running: 0.00 to 50.00 Hz Acceleration/Deceleration time of jog running:0.0s to 6500.0s	
Onboard multiple preset speeds	The system implements up to 16 speeds by using simple PLC function or by using digital input signals.	
Onboard PID	The system implements the proportional integral-derivative (PID) function in the closed-loop control.	
Automatic voltage regulation (AVR)	The system maintains a constant output voltage automatically when the grid voltage changes through the permissible range.	
Overvoltage and overcurrent stall control	The system limits the output current and voltage automatically during operation to prevent frequent or excessive trips.	
Overcurrent fast prevention	The function helps to avoid frequent overcurrent faults.	
Torque limit and control	The system limits the torque automatically to prevent frequent overcurrent tripping during operation. Torque control is applied in vector control.	

Item		Description
Individualized Functions	Power dip ride-through	Load feedback energy compensates for any voltage reduction, allowing the drive to continue to operate for a short time during power dips.
	Overcurrent fast prevention	The function helps to avoid frequent overcurrent faults.
	Virtual I/O	Five groups of virtual digital input/outputs (DI/DO) support simple logic control.
	Timing control	Time range: 0.0 to 6500.0 minutes
	Dual-motor switchover	The drive have two groups of motor parameters and can control up to two motors.
	Multiple field buses	The drive supports four field buses: Modbus, PROFIBUS-DP, CANlink, and CANopen.
	Motor overheat protection	Option: The optional input/output (I/O) extension card allows AI3 to receive a signal from the motor temperature sensor input (PT100, PT1000) to implement motor overheat protection.
	Multiple encoder types	The drive supports a range of different encoder types: Differential encoder, open-collector encoder, and resolver.
	User programmable function	Option: The optional programming card supports secondary development in a programming environment compatible with the Inovance programmable logic controller (PLC).
	Advanced background software	Software in the drive allows users to configure some operating parameters, and provides a virtual oscilloscope display that shows system status.
RUN	Running command	Allows different methods of switching between running commands: Operating panel (keypad & display); terminal I/O control; and serial communication
	Main frequency reference setting channel	Supports up to 10 frequency reference setting channels and allows different methods of switching between frequency reference setting channels: Digital setting Analog voltage reference Analog current reference Pulse reference Communication reference
	Auxiliary frequency reference setting channel	Supports up to 10 auxiliary frequency sources, and allows fine tuning of the auxiliary frequency and main & auxiliary calculation.
	Input terminals	Standard: Five digital input (DI) terminals, one of which supports up to 100 kHz high-speed pulse inputs. Two analog input (AI) terminals, one of which supports only 0 to 10 V input, and the other supports 0 to 10 V and 0 to 20 mA current input. Expanded capacity: Five digital input (DI) terminals. One AI terminal that supports -10 to 10 V voltage input and PT100/PT1000 motor temperature sensor inputs.
	Output terminals	Standard: Single high-speed pulse output terminal (open-collector) for a square-wave signal output In the frequency range 0 to 100 kHz Single digital output (DO) terminal Single relay output terminal Single analog output (AO) terminal that supports either a current output in the range 0 to 20 mA or a voltage output in the range 0 to 10 V. Expanded capacity: Single digital output (DO) terminal Single relay output terminal Single analog output (AO) terminal that supports either a current output in the range 0 to 20 mA or a voltage output in the range 0 to 10 V.

8 Specifications and Model Selection

Item		Description
Display and operating panel	LED display	It shows parameter values.
	LCD display	It is optional and shows parameters in Chinese or English.
	Copy	The LCD operating panel can be used to copy parameters quickly.
	Key locking and function selection	Keys on the control panel can be locked or partially locked electronically to prevent accidental operation.
Protections	Phase loss protection	Input phase loss protection Output phase loss protection
	Instantaneous overcurrent protection	Stop when 250% of rated output current is exceeded.
	Overvoltage protection	Stop when the DC bus voltage is above 820 V.
	Overvoltage protection	Stop when the DC bus voltage is below 350 V.
	Overheat protection	Protection triggered when the AC Drive bridge gets overheated.
	Overload protection	Stop after running at 150% of rated current for 60 seconds.
	Overcurrent protection	Stop when 2.5 times of rated current of the AC drive is exceeded.
	Braking protection	Braking unit overload protection Braking resistor short-circuit protection
	Short-circuit protection	Output phase-to-phase short-circuit protection Output phase-to-ground short-circuit protection
Environment	Installation location	Install the AC Drive where it is indoors and protected from direct sunlight, dust, corrosive or combustible gases, oil smoke, vapor, ingress from water or any other liquid, and salt.
	Altitude	Below 1000 m If the altitude exceeds 1000 m, de-rating by 1% for per 100 m increase Max. 3000 m (Note: The maximum altitude for 0.4 to 3 kW drives is 2000 m. For use at altitude over 2000 m, contact Inovance.)
	Ambient temperature:	-10°C to +40°C. If the ambient temperature is not in this range, de-rating by 1.5% per 1°C increase. Max. temperature: 50°C
	Humidity	Less than 95% RH non-condensing
	Vibration	Less than 5.9 m/s ² (0.6 g)
	Storage temperature	-20°C to +60°C

8.2 Appearance and Dimensions of MD500E Series AC Drive

8.2.1 Overall Dimensions of MD500ET0.4GB to MD500ET160G

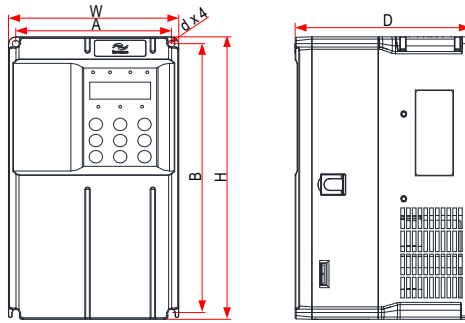

Figure 8-1 Mounting Dimensions of MD500ET0.4GB to MD500ET15GB

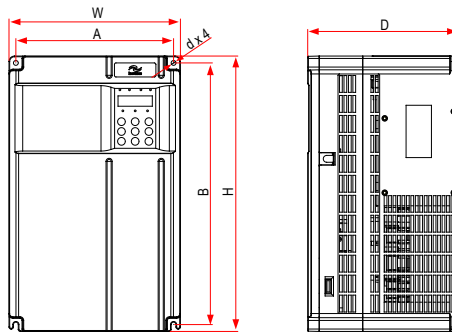

Figure 8-2 Mounting Dimensions of MD500ET18.5G(B) to MD500ET37G(B)

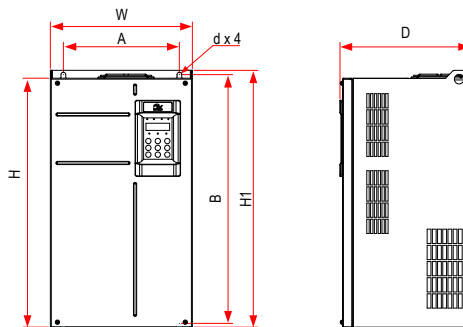

Figure 8-3 Mounting Dimensions of MD500ET45G(B) to MD500ET160G

Table 8-3 Mounting Hole Dimensions of MD500ET0.4GB to MD500ET160G

AC Drive Model	Hole Dimensions (mm)		Overall Dimensions (mm)				Hole Diameter (mm)	Weight (kg)
	A	B	H	H1	W	D		
MD500ET0.4GB	119	189	200	/	130	152	Ø5	1.6
MD500ET0.7GB								
MD500ET1.1GB								
MD500ET1.5GB								
MD500ET2.2GB								
MD500ET3.0GB								
MD500ET3.7GB	119	189	200	/	130	162	Ø5	2.0
MD500ET5.5GB								
MD500ET7.5GB	128	238	250	/	140	170	Ø6	3.3
MD500ET11GB								
MD500ET15GB	166	266	280	/	180	170	Ø6	4.3
MD500ET18.5G(B)	195	335	350	/	210	192	Ø6	7.6
MD500ET22G(B)								
MD500ET18.5G(B)-T	195	335	350	/	210	192	Ø6	10.0
MD500ET22G(B)-T								
MD500ET30G(B)	230	380	400	/	250	220	Ø7	17.5
MD500ET37G(B)								
MD500ET45G(B)	245	523	525	542	300	275	Ø10	35.0
MD500ET55G(B)								
MD500ET75G(B)	270	560	554	580	338	315	Ø10	51.5
MD500ET90G								
MD500ET110G								
MD500ET132G	320	890	874	915	400	320	Ø10	85.0
MD500ET160G								

8.2.2 Overall Dimension of MD500ET0.4GB to MD500ET160G with Through Hole Mounting Bracket

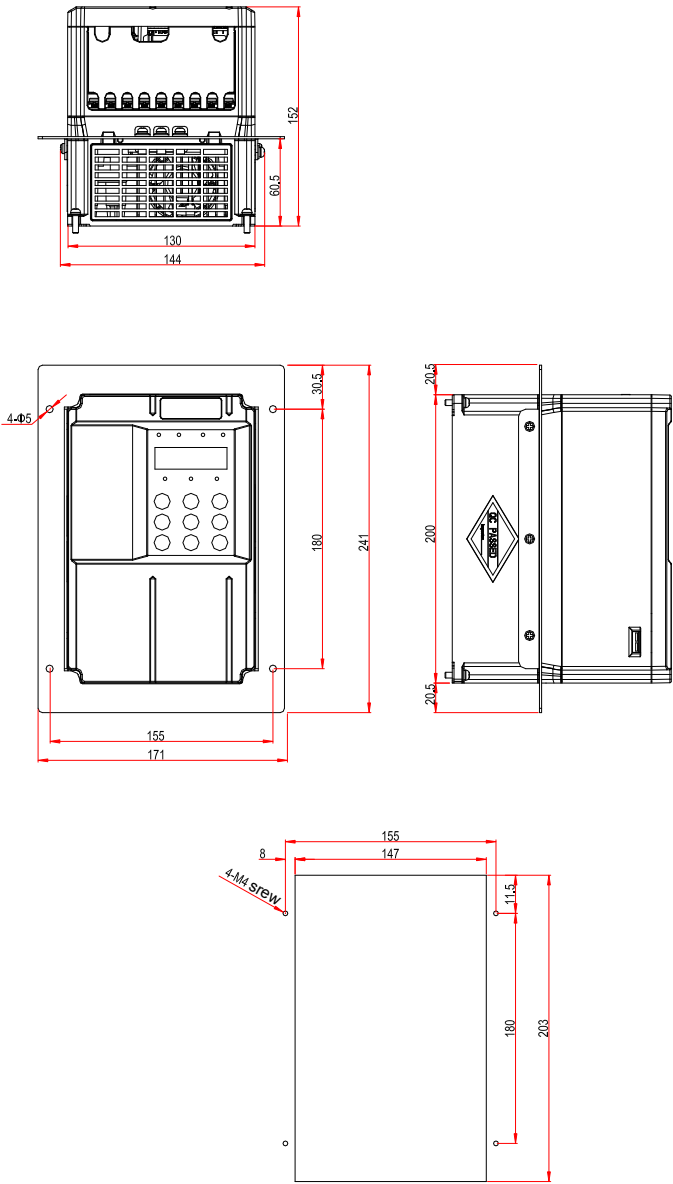

Figure 8-4 Dimensions of through hole mounting bracket and hole of MD500ET0.4GB to MD500ET3.0GB

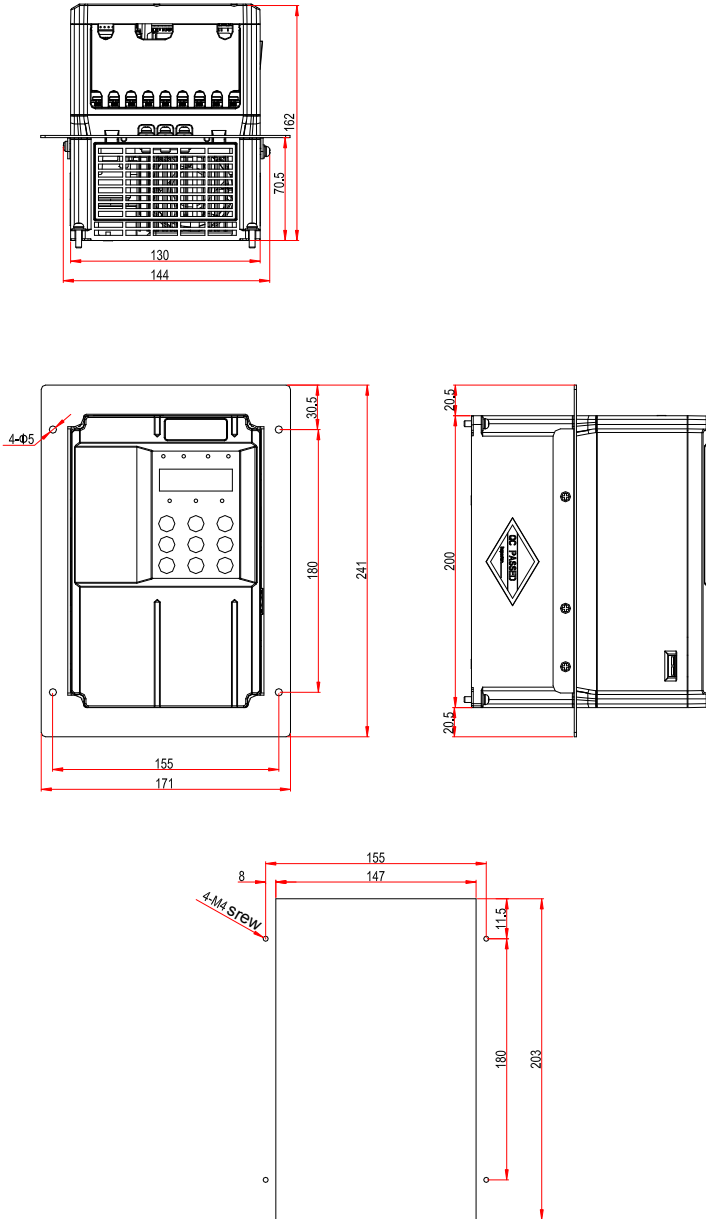

Figure 8-5 Dimensions of through hole mounting bracket and hole of MD500ET3.7GB to MD500ET5.5GB

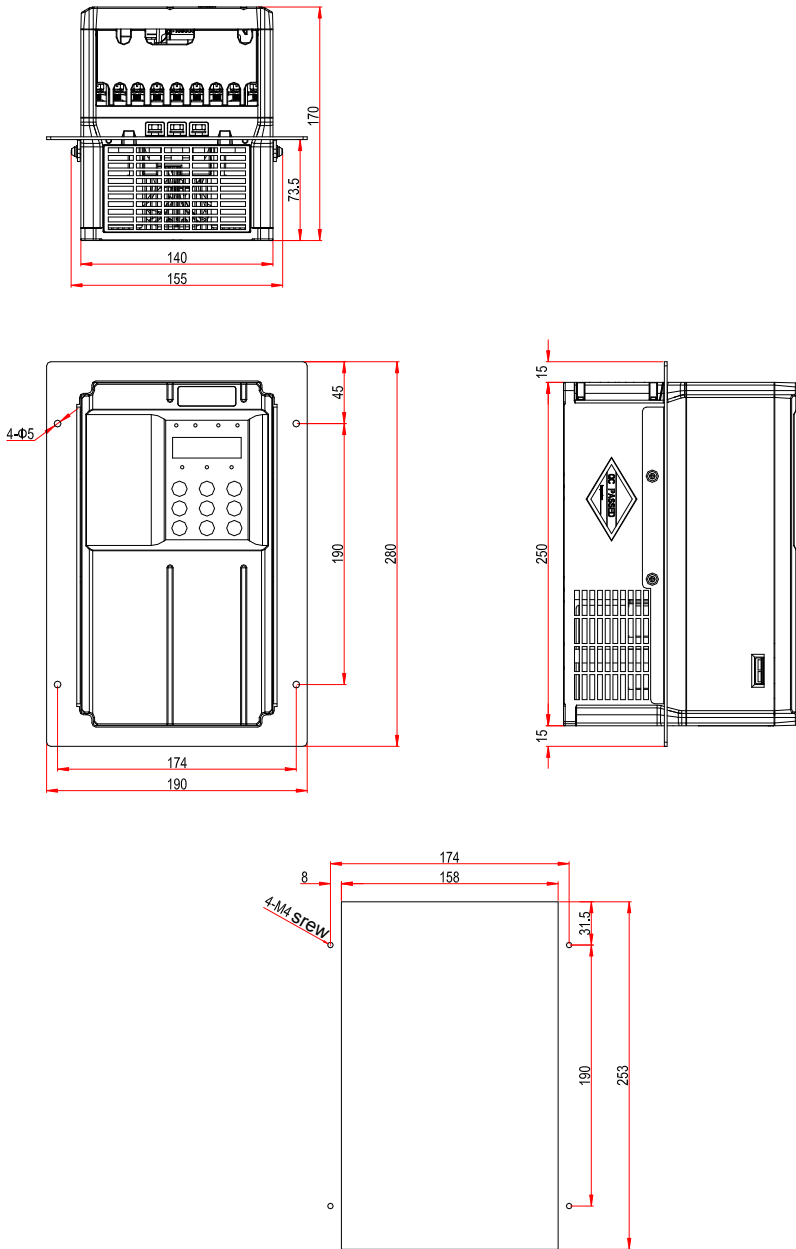

Figure 8-6 Dimensions of through hole mounting bracket and hole of MD500ET7.5GB to MD500ET11GB

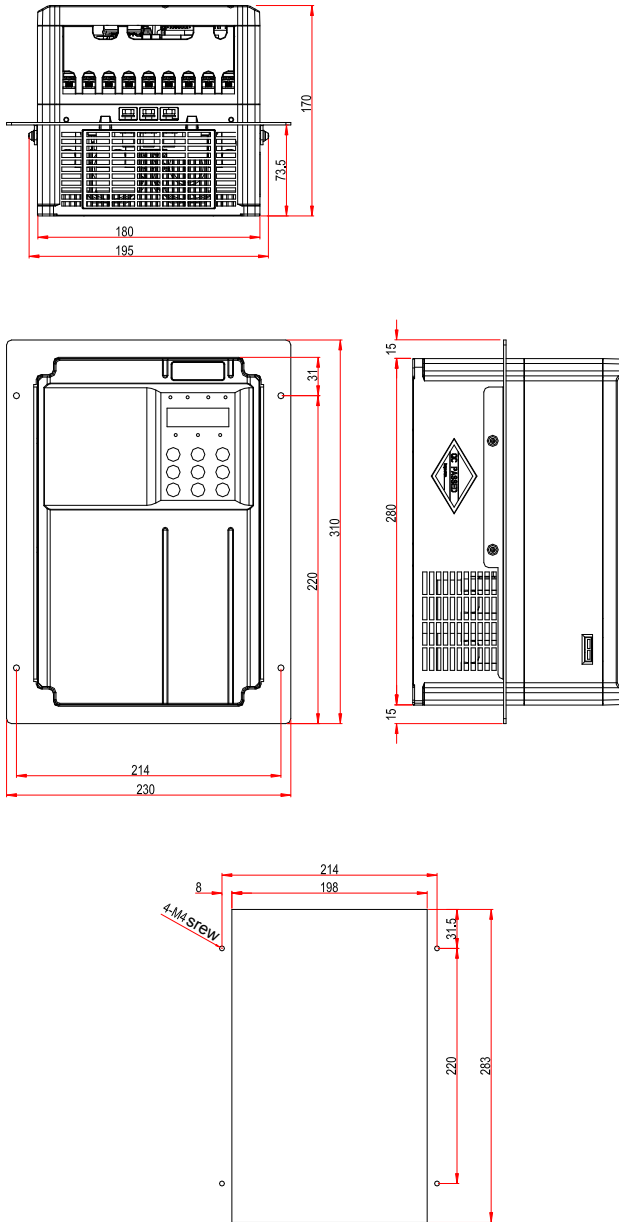

Figure 8-7 Dimensions of through hole mounting bracket and hole of MD500ET15GB

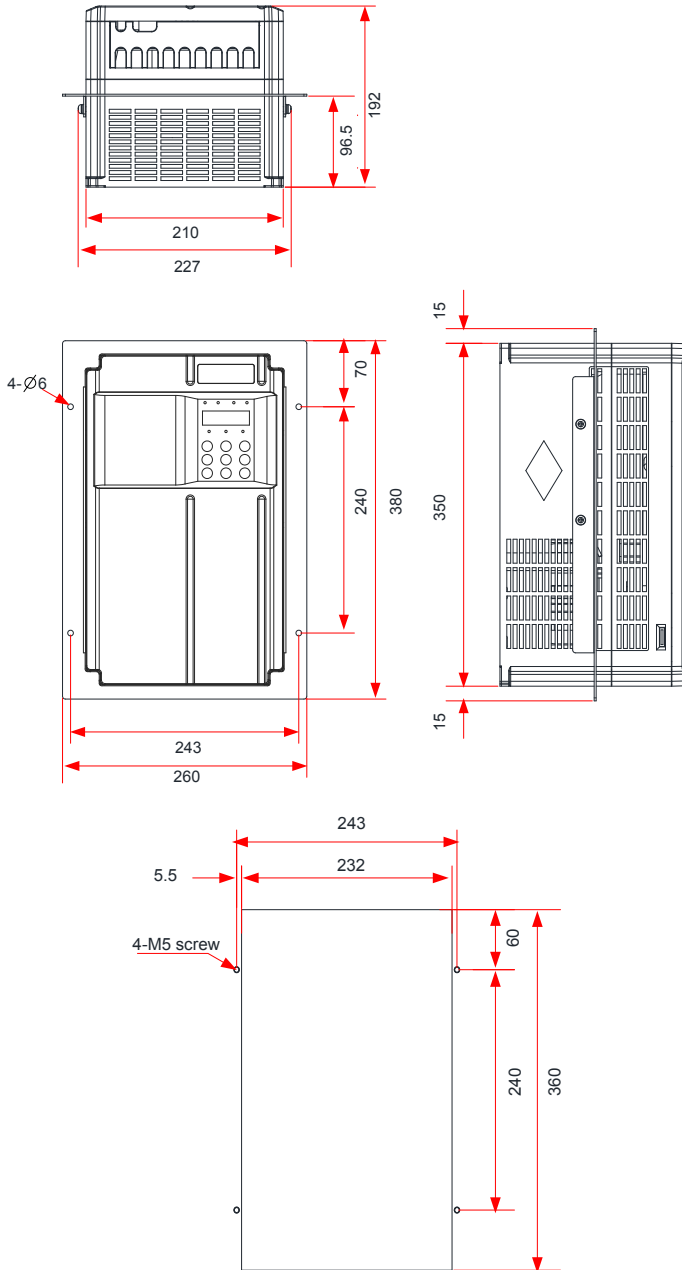

Figure 8-8 Dimensions of through hole mounting bracket and hole of MD500ET18.5G(B)(-T) to MD500ET-22G(B)(-T)

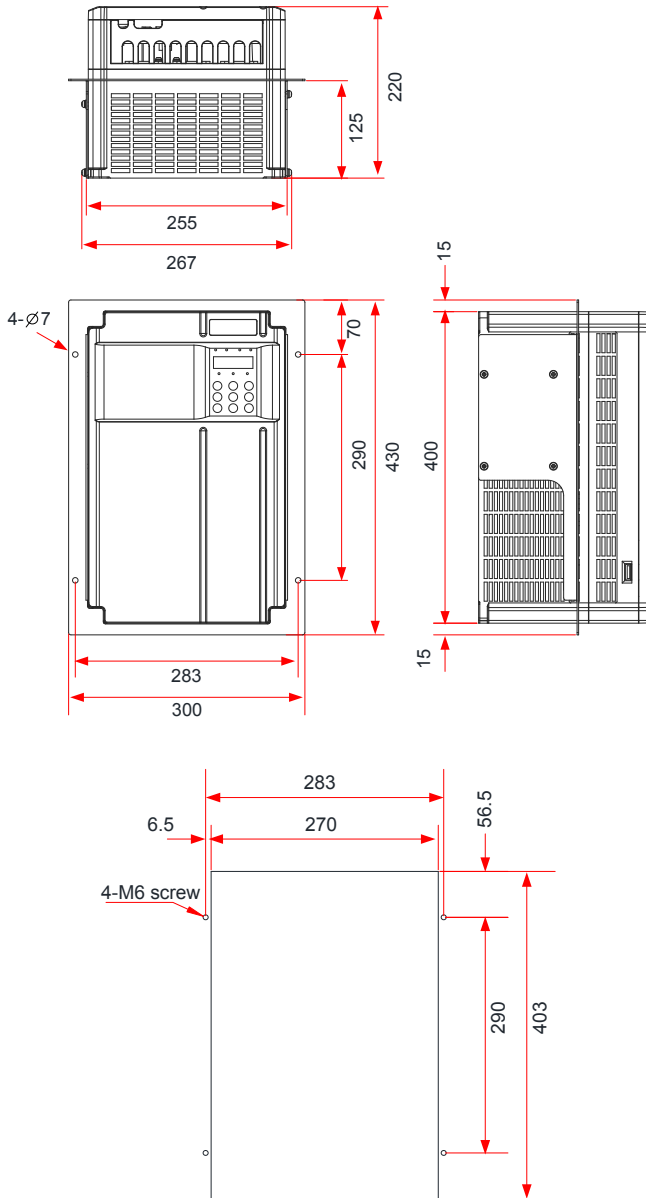

Figure 8-9 Dimensions of through hole mounting bracket and hole of MD500ET30G(B) to MD500ET37G(B)

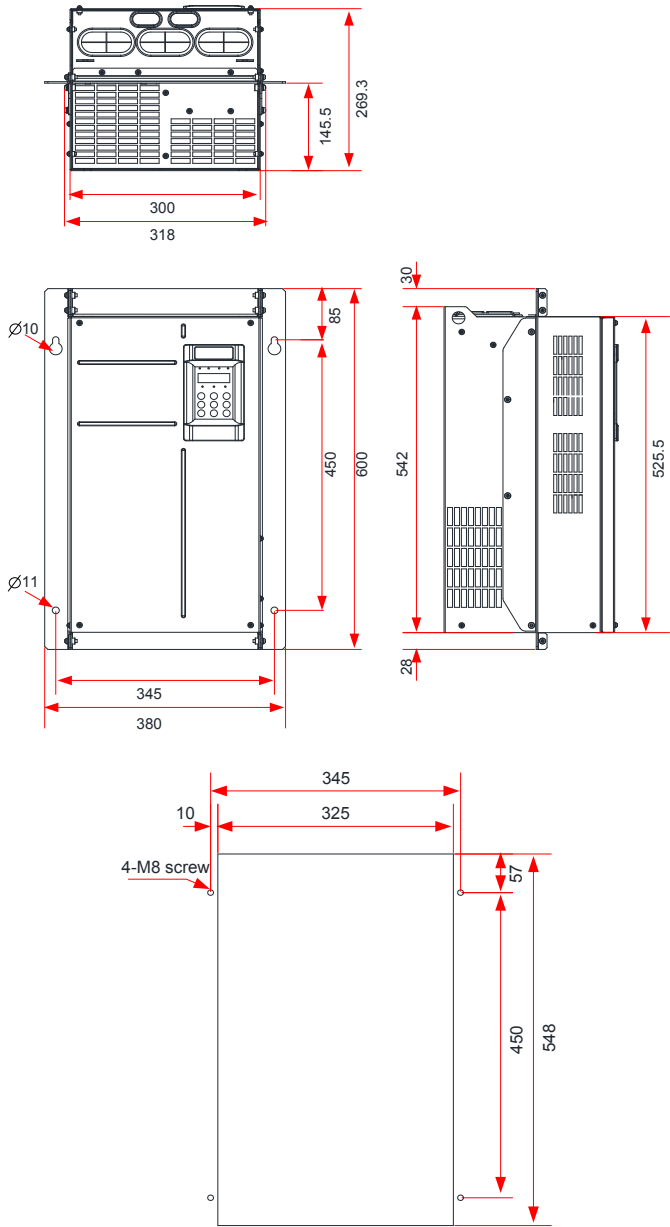

Figure 8-10 Dimensions of through hole mounting bracket and hole of MD500ET45G(B) to MD500ET55G(B)

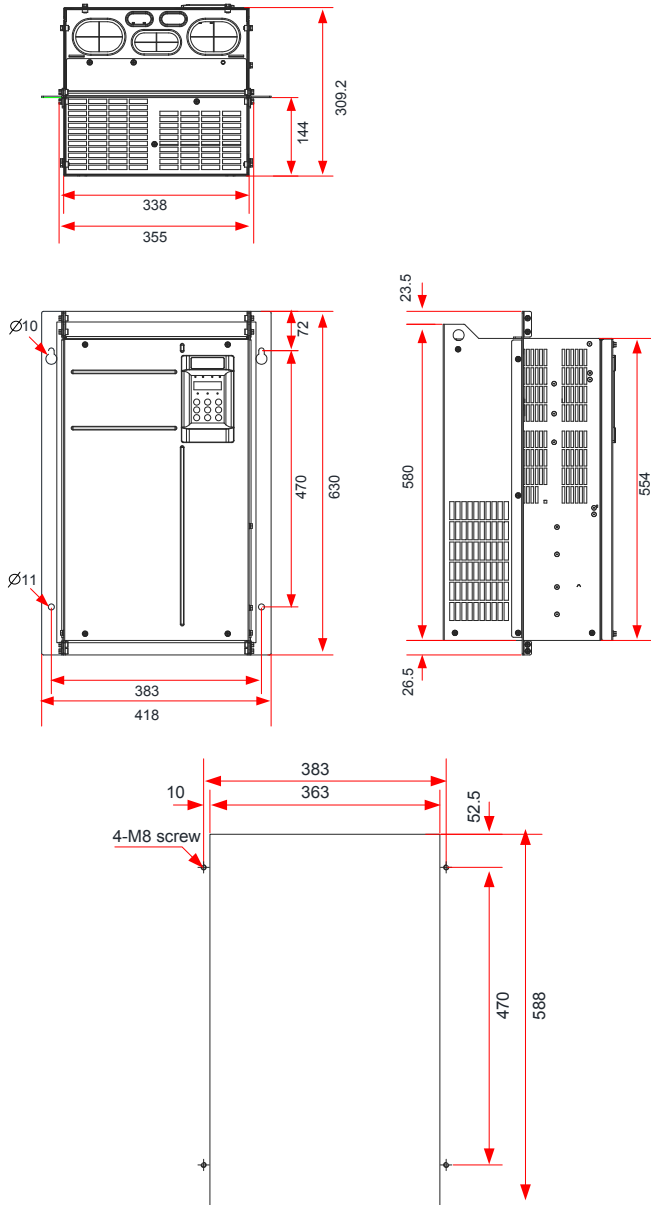

Figure 8-11 Dimensions of through hole mounting bracket and hole of MD500ET75G(B) to MD500ET110G

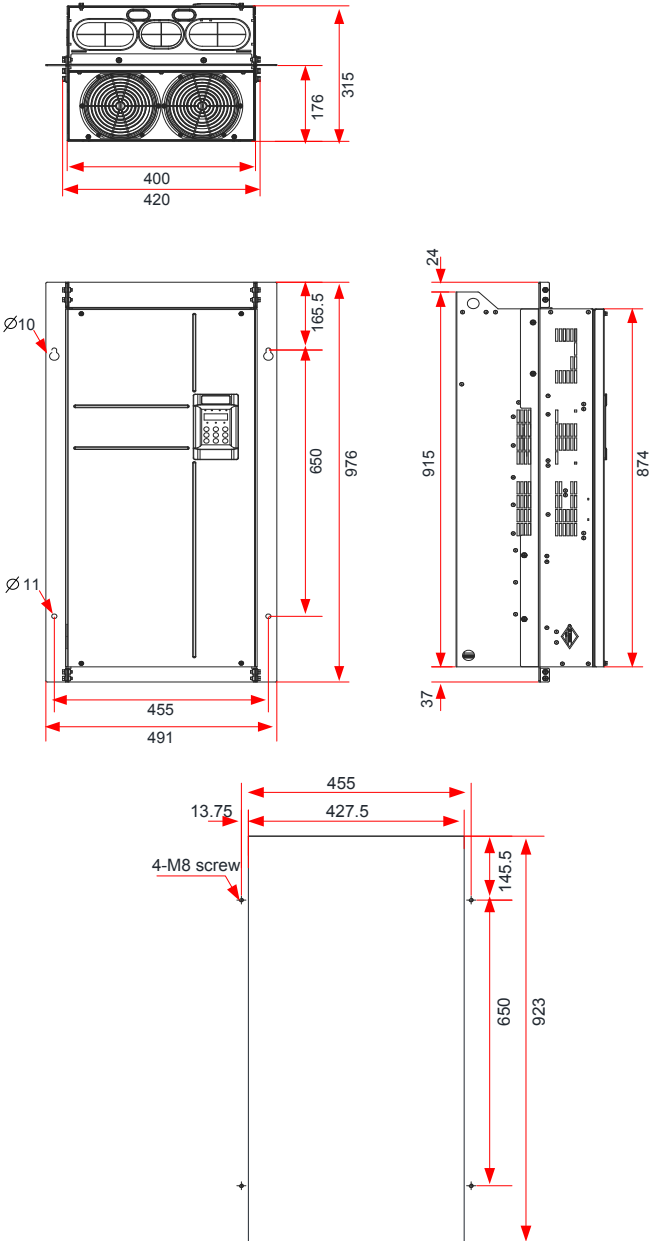

Figure 8-12 Dimensions of through hole mounting bracket and hole of MD500ET132G to MD500ET160G

8.2.3 Overall Dimensions of MD500ET200G to MD500ET450G

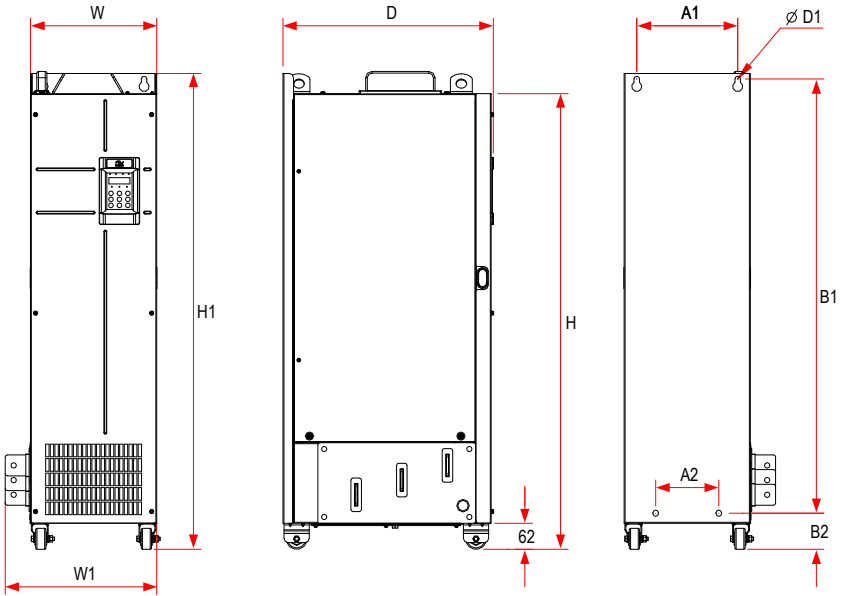

Figure 8-13 Mounting dimensions of MD500ET200G to MD500ET450G

Table 8-4 Mounting hole dimensions of MD500ET200G to MD500ET450G

AC Drive Model	Hole Dimensions (mm)				Overall Dimensions (mm)					Hole Diameter (mm)	Weight (kg)
	A1	A2	B1	B2	H	H1	W	W1	D	D1	
MD500ET200G	240	150	1035	86	1086	1134	300	360	500	Ø13	110
MD500ET220G											
MD500ET250G	225	185	1175	97	1248	1284	330	390	545	Ø13	155
MD500ET280G											
MD500ET315G	240	200	1280	101	1355	1405	340	400	545	Ø16	185
MD500ET355G											
MD500ET400G											
MD500ET450G											

8.2.4 Overall Dimensions of MD500ET200G-L to MD500ET450G-L

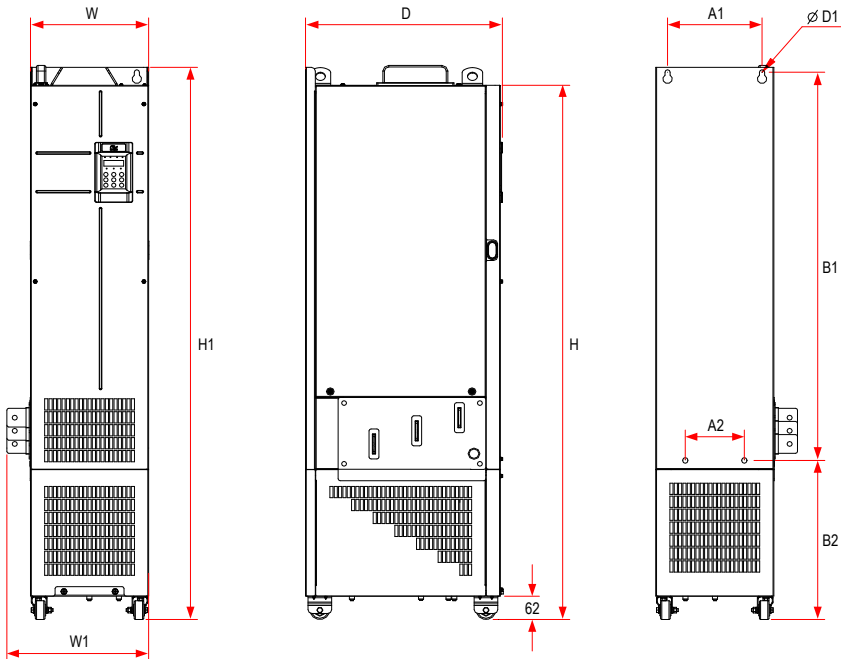

Figure 8-14 Mounting dimensions of MD500ET200G-L to MD500ET450G-L (with reactor base)

Table 8-5 Mounting hole dimensions of MD500ET200G-L to MD500ET450G-L (with reactor base)

AC Drive Model	Hole Dimensions (mm)				Overall Dimensions (mm)					Hole Diameter (mm)	Weight (kg)
	A1	A2	B1	B2	H	H1	W	W1	D		
MD500ET200G-L	240	150	1035	424	1424	1472	300	360	500	Ø13	160
MD500ET220G-L											
MD500ET250G-L	225	185	1175	435	1586	1622	330	390	545	Ø13	215
MD500ET280G-L											
MD500ET315G-L	240	200	1280	432	1683	1733	340	400	545	Ø16	245
MD500ET355G-L											
MD500ET400G-L											
MD500ET450G-L											

8.2.5 Dimensions of Mounting Bracket of MD500ET200G(-L) to MD500ET450G(-L)

■ Dimensions of mounting bracket of MD500ET200G(-L) to MD500ET280G(-L)

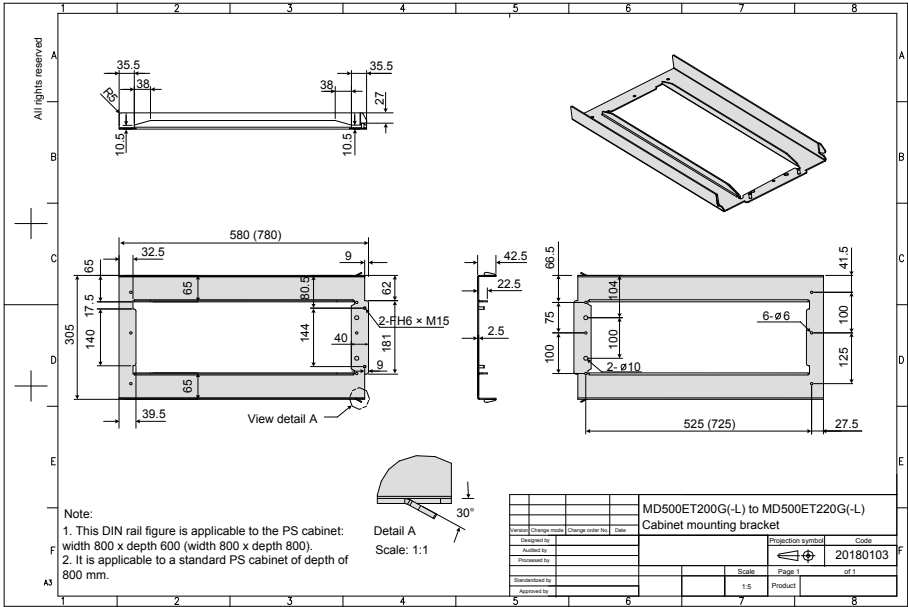

Figure 8-15 Dimensions of mounting bracket of MD500ET200G(-L) to MD500ET220G(-L) (factory standard)

■ Dimensions of mounting bracket of MD500ET250G(-L) to MD500ET280G(-L)

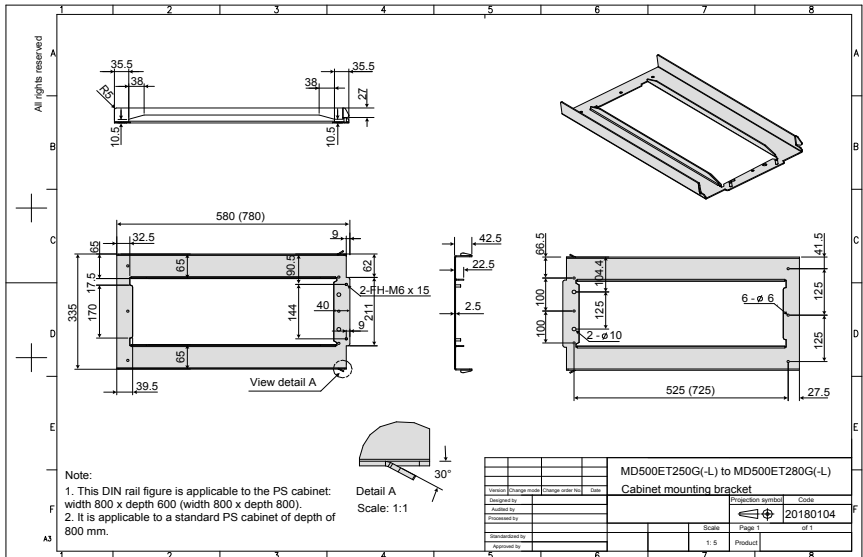

Figure 8-16 Dimensions of mounting bracket of MD500ET250G(-L) to MD500ET280G(-L) (factory standard)

■ Dimensions of mounting bracket of MD500ET315G(-L) to MD500ET450G(-L)

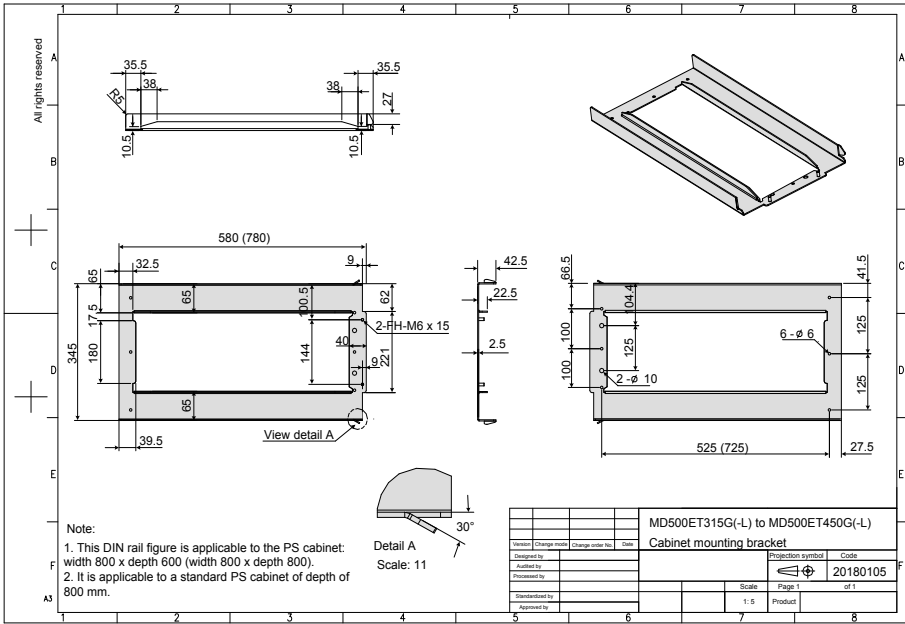

Figure 8-17 Dimensions of mounting bracket of MD500ET315G(-L) to MD500ET450G(-L) (factory standard)

8.3 Options

Peripherals and options include braking units and function extension cards, as listed in the following table. For use of each option, refer to its user manual. If you need to purchase the following options, specify the required option in the order.

Table 8-6 Options of MD500E Series AC drive

Name	Model	Functions	Remark
Onboard braking unit	Marked by "B".	0.4 kW to 75 kW	-
External braking unit	MDBUN and MDBU	90 kW or above	Multiple braking units of 90 kW or above are connected in parallel.
I/O extension card 1	MD38IO1	Provides: Five extra DI terminals An analog input (AI3) A relay output A digital output An analog output Can connect to PT100 and PT1000	Available for models of 15 kW or above
I/O extension card 2	MD38IO2	Provides three extra DI terminals.	Available for all models
RS-485 communication card	MD38TX1	Provides isolated Modbus communication adapter card	Available for all models
CANlink communication card	MD38CAN1	CANlink communication adapter card	Available for all models

8 Specifications and Model Selection

Name	Model	Functions	Remark
CANopen communication card	MD38CAN2	CANopen communication adapter card	Available for all models
Profbus-DP communication card	MD38DP2	Profbus-DP communication card	Available for models of 15 kW or above
User programmable card	MD38PC1	User programmable extension card Compatible with H1U-Series PLCs of Inovance	Available for models of 15 kW or above
Differential encoder interface card	MD38PG1	Differential encoder resolver interface card, 5 V power supply	Available for all models
Resolver interface card	MD38PG4	For use with a resolver that has an excitation frequency of 10 kHz. The card has a DB9 interface.	Available for all models
Open collector encoder interface card	MD38PG5	Open collector encoder interface card, 1:1 frequency dividing, 15 V power supply	Available for all models
Open collector encoder interface card	MD38PG5D	Open collector encoder interface card, optional multiplying frequency division output, 15 V power supply	Available for all models
Differential encoder interface card	MD38PG6	Differential encoder resolver interface card, 5 V power supply	Available for all models
Differential encoder interface card	MD38PG6D	Differential encoder resolver interface card, optional multiplying frequency division output, 5V power supply	Available for all models
MD38PGMD New multi-function encoder card	MD38PGMD	Compatible of differential input, open-collector input, and push-pull input Supports differential output and open-collector output Compatible with A/B phase input interfaces of often-used encoders and host computers.	Available for all models
External LED operating panel	MD32NKE1	Connect to external LED display and operating panel through RJ45	Available for all models
External LCD operating panel	MDKE9	External LCD display and operating panel	Supports parameter copy and download
Extension cable	MDCAB	Standard: 8 cores Can connect to MD32NKE1, MD32KC, and MD32CP	Standard length: 3 m
Through-hole mounting model	MD500E-AZJ-A1T*	Can be used to mount the drive to the middle of the cabinet	Each model has its own bracket. For details, see Table 3-1 Through-hole Mounting Models in Chapter 3.
Cable support bracket	MD500E-AZJ-A2T*	Can be used for secondary fixing of power cables and stable grounding of the shield	Each model has its own bracket. For details, see Table 3-3 Cable support bracket models in Chapter 3.

8.4 Cables, Breakers, and Contactors

6. Recommended Cables, Breakers, and Contactors

Table 8-7 Recommended Peripherals and Options

MD500E Model	Recommended Input IEC Cable (mm ²)<1>	Recommended IEC Ground Cable (mm ²)	Recommended Output IEC Cable (mm ²)	Terminal width (mm)	Screw Specification	Recommended Fuse Bussmann Pass UL Certification		Recommended Contactor	Recommended Breaker
						Rated Current (A)	Model		
Three-phase 380 to 480 V, 50/60 Hz									
MD500ET0.4GB	3 x 0.75	0.75	3 x 0.75	10.2	M4	5	FWP-5B	9	3
MD500ET0.7GB	3 x 0.75	0.75	3 x 0.75	10.2	M4	5	FWP-5B	9	4
MD500ET1.1GB	3 x 0.75	0.75	3 x 0.75	10.2	M4	10	FWP-10B	9	6
MD500ET1.5GB	3 x 0.75	0.75	3 x 0.75	10.2	M4	10	FWP-10B	9	6
MD500ET2.2GB	3 x 0.75	0.75	3 x 0.75	10.2	M4	10	FWP-10B	9	10
MD500ET3.0GB	3 x 1	1	3 x 1	10.2	M4	15	FWP-15B	12	13
MD500ET3.7GB	3 x 1.5	1.5	3 x 1.5	10.2	M4	20	FWP-20B	16	16
MD500ET5.5GB	3 x 2.5	2.5	3 x 2.5	10.2	M4	30	FWP-30B	26	25
MD500ET7.5GB	3 x 4	4	3 x 4	13.0	M5	40	FWP-40B	26	32
MD500ET11GB	3 x 6	6	3 x 6	13.0	M5	60	FWP-60B	38	50
MD500ET15GB	3 x 10	10	3 x 10	14.3	M5	70	FWH-70B	50	63
MD500ET18.5G (B)(-T)	3 x 10	10	3 x 10	15.0	M6	80	FWH-80B	65	63
MD500ET22G (B)(-T)	3 x 16	16	3 x 16	15.0	M6	100	FWH-100B	65	80
MD500ET30G(B)	3 x 16	16	3 x 16	18.0	M6	100	FWH-100B	65	80
MD500ET37G(B)	3 x 25	16	3 x 25	18.0	M6	125	FWH-125B	80	100
MD500ET45G(B)	3 x 35	16	3 x 35	26.8	M8	150	FWH-150B	95	160
MD500ET55G(B)	3 x 50	25	3 x 50	26.8	M8	200	FWH-200B	115	160
MD500ET75G(B)	3 x 70	35	3 x 70	30.6	M12	250	FWH-250A	150	250
MD500ET90G	3 x 95	50	3 x 95	30.6	M12	275	FWH-275A	170	250
MD500ET110G	3 x 120	70	3 x 120	30.6	M12	325	FWH-325A	205	250
MD500ET132G	3 x 150	95	3 x 150	*	M12	400	FWH-400A	245	400
MD500ET160G	3 x 185	95	3 x 185	*	M12	500	FWH-500A	300	400
MD500ET200G(-L)	2 x (3 x 95)	95	2 x (3 x 95)	*	M12	600	FWH-600A	410	500
MD500ET220G(-L)	2 x (3 x 120)	120	2 x (3 x 120)	*	M12	700	FWH-700A	410	630
MD500ET250G(-L)	2 x (3 x 120)	120	2 x (3 x 120)	*	M12	800	FWH-800A	475	630

MD500E Model	Recommended Input IEC Cable (mm ²)<1>	Recommended IEC Ground Cable (mm ²)	Recommended Output IEC Cable (mm ²)	Terminal width (mm)	Screw Specification	Recommended Fuse Bussmann Pass UL Certification		Recommended Contactor	Recommended Breaker
						Rated Current (A)	Model		
MD500ET280G(-L)	2 x (3 x 150)	150	2 x (3 x 150)	*	M12	800	FWH-800A	620	800
MD500ET315G(-L)	2 x (3 x 185)	185	2 x (3 x 185)	*	M16	1000	170M5016	620	800
MD500ET355G(-L)	2 x (3 x 185)	185	2 x (3 x 185)	*	M16	1000	170M5016	620	800
MD500ET400G(-L)	2 x (3 x 240)	240	2 x (3 x 240)	*	M16	1400	170M6017	800	1000
MD500ET450G(-L)	2 x (3 x 240)	240	2 x (3 x 240)	*	M16	1400	170M6017	800	1000

Note • <1>Chinese laws are applicable. 3 x 10 indicates a three-core cable, and 2 x (3 x 95) indicates two 3-core cables.

7. Circuit Breaker

When the leakage current is over 3.5 mA, the AC drive must be grounded. AC drive generates DC leakage current in protective conductor. In this case, a time-delay B-type breaker must be used.

When leakage current causes the circuit-breaker to act, you should:

- Use a circuit-breaker with higher rated action current or a delay-action circuit-breaker.
- Reduce carrier frequency.
- Shorten length of the output cable.
- Increase sensitivity current of circuit-breaker.
- Recommended residual current circuit-breaker manufacturers are Chint Electric and Schneider.

8.5 Braking Unit

8.5.1 Selection of Resistance of Braking Resistor

The AC drive transfers regenerative energy generated during braking of motor to external braking resistor. According to formula $U \times U/R = P_b$:

- U refers to braking voltage at system stable braking. (Its value varies with the system. The default braking voltage of MD500E Series is 760 V. You can set F9-08 to change the value.)
- P_b refers to braking power.

8.5.2 Selection of Power of Braking Resistor

In theory, power of braking resistor is the same as braking power. But in consideration of de-rating, power of braking resistor is calculated from the following formula: $K \times P_r = P_b \times D$

- K is about 50%.
- P_r refers to power of braking resistor.
- D refers to braking frequency (percentage of regenerative process to whole deceleration).

The following two formulas can be obtained:

$$K \times P_r = P_b \times D = (U \times U)/(R \times D)$$

$$P_r = (U \times U \times D)/(R \times K)$$

The user can calculate braking resistor power.

K is de-rating coefficient of braking resistor. Low K value can ensure that braking resistor does not get over-

heated. The K value can be increased appropriately on the condition of good dissipation and should not exceed 50%. Failure to comply may result in a fire due to overheating of braking resistor.

Braking frequency (D) is determined by application. Typical values of braking frequency in different applications are listed in the Table 8-8.

Table 8-8 Typical values of braking frequency in different applications

Application	Elevator	Winding & Unwinding	Centrifuge	Occasional Braking Load	General Application
Braking Frequency	20% to 30%	20 % to 30%	50% to 60%	5%	10%

8.5.3 Braking Units

Table 8-9 Selection of braking units

AC Drive Model	Applicable Motor (kW)	Braking Unit		125% Braking Torque (10% ED, Max. 10s)		Remark	Min. Resistance of Braking Resistor (Ω)		
		Model	QTY	Recommended braking resistor Specification	QTY				
MD500ET0.4GB	0.4	Built-in		80W 1450 Ω	1	AC drive model ending with letter "B"	96		
MD500ET0.7GB	0.75			140W 800 Ω	1		96		
MD500ET1.1GB	1.1			220W 500 Ω	1		96		
MD500ET1.5GB	1.5			300W 380 Ω	1		64		
MD500ET2.2GB	2.2			440W 260 Ω	1		64		
MD500ET3.0GB	3			600W 190 Ω	1		32		
MD500ET3.7GB	3.7			740W 150 Ω	1		32		
MD500ET5.5GB	5.5			1100W 100 Ω	1		32		
MD500ET7.5GB	7.5			1500W 75 Ω	1		32		
MD500ET11GB	11			2200W 50 Ω	1		20		
MD500ET15GB	15			3000W 38 Ω	1		20		
MD500ET18.5G(B)(-T)	18.5			Built-in			4000W 32 Ω	1	24
MD500ET22G(B)(-T)	22						4500W 27 Ω	1	24
MD500ET30G(B)	30	6000W 20 Ω	1			19.2			
MD500ET37G(B)	37	7000W 16 Ω	1			14.8			
MD500ET45G(B)	45	9000W 13 Ω	1			12.8			
MD500ET55G(B)	55	11000W 10.5 Ω	1			9.6			
MD500ET75G(B)	75	15000W 7.7 Ω	1			6.8			
MD500ET90G	90	MDBUN-60-T	2			9000W 10.0 Ω	2	Input voltage \leq 440 VAC	9.3 \times 2
	90	MDBUN-60-ST	2			9000W 12.8 Ω	2	Input voltage $>$ 440 VAC	10.5 \times 2
MD500ET110G	110	MDBUN-60-T	2			11000W 9.4 Ω	2	Input voltage \leq 440 VAC	9.3 \times 2
	110	MDBUN-60-ST	2	11000W 10.5 Ω	2	Input voltage $>$ 440 VAC	10.5 \times 2		

8 Specifications and Model Selection

AC Drive Model	Applicable Motor (kW)	Braking Unit		125% Braking Torque (10% ED, Max. 10s)		Remark	Min. Resistance of Braking Resistor (Ω)
		Model	QTY	Recommended braking resistor Specification	QTY		
MD500ET132G	132	MDBUN-90-T	2	13000W 6.8 Ω	2	Input voltage \leq 440 VAC	6.2 \times 2
	132	MDBUN-90-5T	2	13000W 8.8 Ω	2	Input voltage $>$ 440 VAC	7.0 \times 2
MD500ET160G	160	MDBUN-90-T	2	16000W 6.3 Ω	2	Input voltage \leq 440 VAC	6.2 \times 2
	160	MDBUN-90-5T	2	16000W 7.2 Ω	2	Input voltage $>$ 440 VAC	7.0 \times 2
MD500ET200G(-L)	200	MDBU-200-B	2	19000W 4.5 Ω	2	Input voltage \leq 440 VAC	2.5 \times 2
	200	MDBU-200-C	2	19000W 5.8 Ω	2	Input voltage $>$ 440 VAC	3.0 \times 2
MD500ET220G(-L)	220	MDBU-200-B	2	21000W 4.1 Ω	2	Input voltage \leq 440 VAC	2.5 \times 2
	220	MDBU-200-C	2	21000W 5.3 Ω	2	Input voltage $>$ 440 VAC	3.0 \times 2
MD500ET250G(-L)	250	MDBU-200-B	2	24000W 3.6 Ω	2	Input voltage \leq 440 VAC	2.5 \times 2
	250	MDBU-200-C	2	24000W 4.6 Ω	2	Input voltage $>$ 440 VAC	3.0 \times 2
MD500ET280G(-L)	280	MDBU-200-B	2	27000W 3.2 Ω	2	Input voltage \leq 440 VAC	2.5 \times 2
	280	MDBU-200-C	2	27000W 4.1 Ω	2	Input voltage $>$ 440 VAC	3.0 \times 2
MD500ET315G(-L)	315	MDBU-200-B	3	20000W 4.3 Ω	3	Input voltage \leq 440 VAC	2.5 \times 3
	315	MDBU-200-C	3	20000W 5.5 Ω	3	Input voltage $>$ 440 VAC	3.0 \times 3
MD500ET355G(-L)	355	MDBU-200-B	3	23000W 3.8 Ω	3	Input voltage \leq 440 VAC	2.5 \times 3
	355	MDBU-200-C	3	23000W 4.9 Ω	3	Input voltage $>$ 440 VAC	3.0 \times 3
MD500ET400G(-L)	400	MDBU-200-B	3	26000W 3.4 Ω	3	Input voltage \leq 440 VAC	2.5 \times 3
	400	MDBU-200-C	3	26000W 4.3 Ω	3	Input voltage $>$ 440 VAC	3.0 \times 3
MD500ET450G(-L)	450	MDBU-200-B	3	29000W 3.0 Ω	3	Input voltage \leq 440 VAC	2.5 \times 3
	450	MDBU-200-C	3	29000W 3.9 Ω	3	Input voltage $>$ 440 VAC	3.0 \times 3

Note

- Minimum resistance supports operating condition with ED of 10% and longest time for single braking of 10s.
- Default initial braking voltage for built-in breakers is 760 V when the input voltage is no more than 440 VAC. Default initial braking voltage is 670 V for MDBUN-60-T, MDBUN-90-T, and MDBU-200-B, and 760 V for MDBUN-60-5T, MDBUN-90-5T, and MDBU-200-C when the input voltage is above 440 VAC. Resistance of braking resistor can be adjusted with the initial braking voltage.
- The preceding table is for a reference only. You can select resistance and power of braking resistor based on actual needs. Resistance must not be lower than the reference value. Power may be higher than the reference value. Selection of braking resistor model is determined by generation power of motor and is also related to system inertia, deceleration time and potential energy load. For systems with high inertia, and/or short deceleration time, and/or frequent braking, select a braking resistor with higher power and lower resistance value.

8.5.4 Appearance and Mounting Dimensions of Braking Units

1. Mounting Dimensions of MDBUN Series Braking Unit (mm)

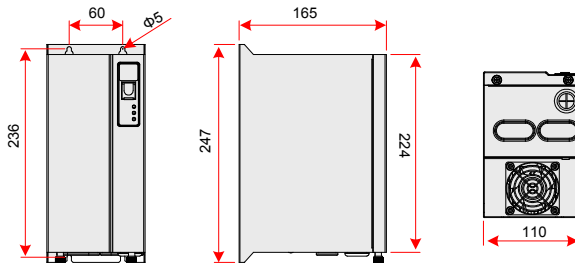

Figure 8-18 Mounting dimensions of MDBUN series braking unit (mm)

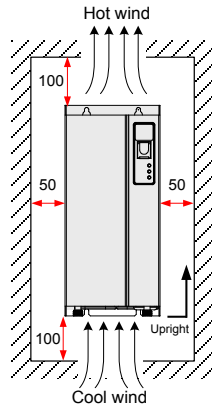

Figure 8-19 Mounting clearance of MDBUN series braking unit (mm)

2. Mounting Dimensions of MDBU Series Braking Unit (mm)

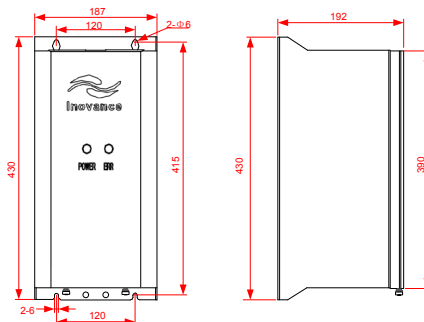

Figure 8-20 Mounting dimensions of MDBU series braking unit (mm)

Note

- For use and installation of MDBUN series braking unit, refer to the MDBUN Series Braking Unit User Guide.
- For use and installation of MDBU series braking unit, refer to the MDBU Series Braking Unit User Guide.

8.5.5 Appearance and Mounting Dimensions of the AFE Unit

The AC drive of Inovance can be configured with the AFE unit, which can feedback energy produced during motor braking to the grid, saving a braking unit and a braking resistor and reducing heating pollution on surrounding environment. The AFE unit has advantages of energy saving, low noise, low harmonics pollution and high power factor.

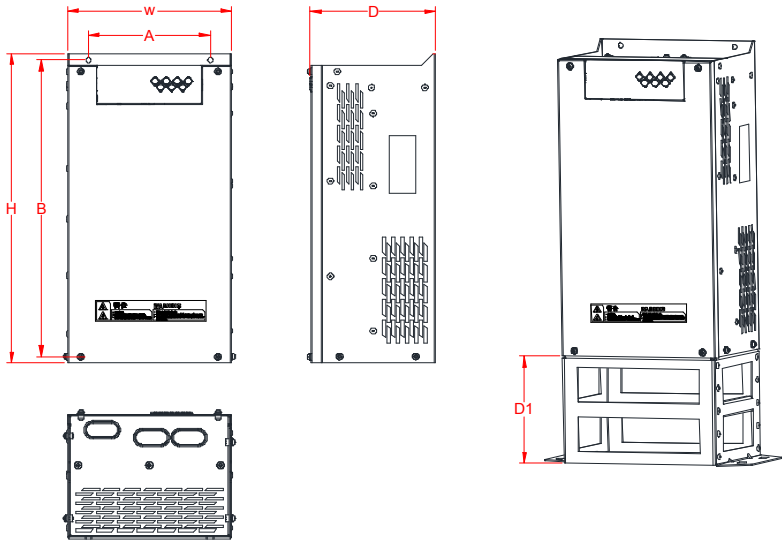

Figure 8-21 Overall dimensions of the AFE unit in MD051N

Table 8-10 Overall dimensions of the AFE unit (mm)

AFE Model	Overall Dimensions			Bracket D1	Hole Dimensions		Hole Diameter Φ	Weight (kg)
	H	W	D		A	B		
MD051NT5.5G	365	200	153	121	160	350	6.0	8.5
MD051NT7.5G								8.7
MD051NT11G								9.0
MD051NT15G	405	215	165	142	160	390	7.0	14.0
MD051NT18.5G								14.8
MD051NT22G	505	260	171	161	160	490	7.0	18.2
MD051NT30G								20.0

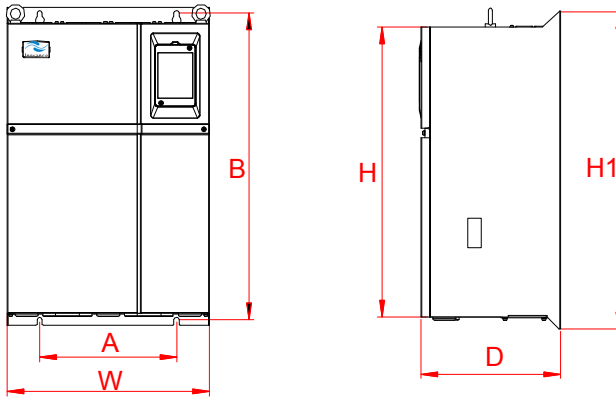

Figure 8-22 Overall dimensions of the AFE unit in MD050

Table 8-11 Overall dimensions of the AFE unit in MD050

AC Drive Model	Overall Dimensions (mm)				Hole Dimensions (mm)		Hole Diameter (mm)	Weight (kg)
	H	H1	W	D	A	B		
MD050-T37G	549	600	385	265	260	580	10	32
MD050-T45G								
MD050-T55G								
MD050-T75G	660	700	473	307	343	678	10	47
MD050-T90G								
MD050-T110G	880	930	579	380	449	903	10	90
MD050-T132G								
MD050-T160G								
MD050-T200G	983	1060	650	377	420	1030	12	130
MD050-T220G								
MD050-T250G								
MD050-T280G								
MD050-T315G	1203	1358	800	400	520	1300	14	200
MD050-T355G								
MD050-T400G								
MD050-T450G								

Note

- For installation and use of the AFE unit, refer to 19010310 MD051 AFE User Manual or 19010130 MD050 AFE User Manual.

8.6 AC Output Reactor

Whether to install an AC output reactor on power output side is dependent on actual situation. Cable connecting AC drive and motor should not be too long; capacitance enlarges when an over-long cable is used and thus high-harmonics current may be easily generated.

If the output cable is too long, install an AC output reactor. To avoid these problems, install an AC output reactor close to the drive if cable is equal to or longer than the value in below table.

Table 8-12 Cable length limit

AC Drive Power (kW)	Rated Voltage (V)	Cable Length Limit (m)
0.4 to 4	200 to 500	50
5.5	200 to 500	70
7.5	200 to 500	100
11	200 to 500	110
15	200 to 500	125
18.5	200 to 500	135
≥ 22	200 to 500	150

Table 8-13 Recommended AC output reactor manufacturers and models

AC Drive Model	AC Output Reactor Model (Inovance)
MD500ET0.4GB	MD-OCL-5-1.4-4T-1%
MD500ET0.7GB	MD-OCL-5-1.4-4T-1%
MD500ET1.1GB	MD-OCL-5-1.4-4T-1%
MD500ET1.5GB	MD-OCL-5-1.4-4T-1%
MD500ET2.2GB	MD-OCL-7-1.0-4T-1%
MD500ET3.0GB	MD-OCL-10-0.7-4T-1%
MD500ET3.7GB	MD-OCL-10-0.7-4T-1%
MD500ET5.5GB	MD-OCL-15-0.47-4T-1%
MD500ET7.5GB	MD-OCL-20-0.35-4T-1%
MD500ET11GB	MD-OCL-30-0.23-4T-1%
MD500ET15GB	MD-OCL-40-0.18-4T-1%
MD500ET18.5G(B)(-T)	MD-OCL-50-0.14-4T-1%
MD500ET22G(B)(-T)	MD-OCL-60-0.12-4T-1%
MD500ET30G(B)	MD-OCL-80-0.087-4T-1%
MD500ET37G(B)	MD-OCL-90-0.078-4T-1%
MD500ET45G(B)	MD-OCL-120-0.058-4T-1%
MD500ET55G(B)	MD-OCL-150-0.047-4T-1%
MD500ET75G(B)	MD-OCL-200-0.035-4T-1%
MD500ET90G	MD-OCL-250-0.028-4T-1%
MD500ET110G	MD-OCL-250-0.028-4T-1%
MD500ET132G	MD-OCL-330-0.021-4T-1%
MD500ET160G	MD-OCL-330-0.021-4T-1%

Note

- Use AC output reactors of MD500ET200G to MD500E450G for AC drives MD500ET200G-L to MD500E450G-L.

8.7 Applicable Motor

1. A four-pole squirrel-cage asynchronous induction motor is the standard applicable motor. For non-standard applicable motors, select an AC drive of required rated current.
2. In non-AC drive motors, the cooling fan and rotor shaft are coaxially connected. Cooling effect is reduced at low speed. A Cooling fan with better cooling effect or an AC drive motor must be used to avoid motor overheating.
3. AC drive provides standard parameters for applicable motors. You can set a value or modify the default value of the motor according to actual needs; otherwise, the motor running performance or protection may be affected.
4. Alarm or even motor explosion may occur due to short circuit of cables or the motor. Perform insulation short circuit test on the motor and cables installed for the first time and routinely do this test. During the test, the AC drive must be disconnected from the tested parts.

Table 8-14 Applicable motors

AC Drive Model	Power Capacity (kVA)	Input Current (A)	Output current (A)	Applicable Motor		Thermal Design Power (kW)
				(kW)	(HP)	
Three-phase, 440 V, 50-60 Hz						
MD500ET0.4GB	2	1.8	1.5	0.4	0.5	0.039
MD500ET0.7GB	2.8	2.4	2.1	0.75	1	0.046
MD500ET1.1GB	4.1	3.7	3.1	1.1	1.5	0.057
MD500ET1.5GB	5	4.6	3.8	1.5	2	0.068
MD500ET2.2GB	6.7	6.3	5.1	2.2	3	0.081
MD500ET3.0GB	9.5	9.0	7.2	3	4	0.109
MD500ET3.7GB	12	11.4	9.0	3.7	5	0.138
MD500ET5.5GB	17.5	16.7	13.0	5.5	7.5	0.201
MD500ET7.5GB	22.8	21.9	17.0	7.5	10	0.24
MD500ET11GB	33.4	32.2	25.0	11	15	0.355
MD500ET15GB	42.8	41.3	32.0	15	20	0.454
MD500ET18.5G(B)(-T)	45	49.5	37	18.5	25	0.478
MD500ET22G(B)(-T)	54	59	45	22	30	0.551
MD500ET30G(B)	52	57	60	30	40	0.694
MD500ET37G(B)	63	69	75	37	50	0.815
MD500ET45G(B)	81	89	91	45	60	1.01
MD500ET55G(B)	97	106	112	55	75	1.21
MD500ET75G(B)	127	139	150	75	100	1.57
MD500ET90G	150	164	176	90	125	1.81
MD500ET110G	179	196	210	110	150	2.14
MD500ET132G	220	240	253	132	180	2.85
MD500ET160G	263	287	304	160	220	3.56
MD500ET200G(-L)	334	365	377	200	275	4.15

AC Drive Model	Power Capacity (kVA)	Input Current (A)	Output current (A)	Applicable Motor		Thermal Design Power (kW)
				(kW)	(HP)	
MD500ET220G(-L)	375	410	426	220	300	4.55
MD500ET250G(-L)	404	441	465	250	340	5.06
MD500ET280G(-L)	453	495	520	280	380	5.33
MD500ET315G(-L)	517	565	585	315	430	5.69
MD500ET355G(-L)	565	617	650	355	485	6.31
MD500ET400G(-L)	629	687	725	400	545	6.91
MD500ET450G(-L)	715	782	820	450	615	7.54

8.8 Mounting Dimensions of External Operating Panels

1. MD32NKE1

MD32NKE1 is the external operating panel applicable to the drive. It adopts the LED display and has the same operation mode as the operating panel on the drive. It is optional and easy to debug. The following figures show the appearance and mounting dimensions of MD32NKE1.

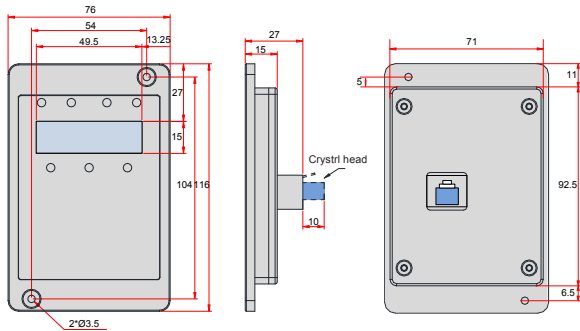

Figure 8-23 Mounting dimensions of MD32NKE1

2. MDKE9

MDKE9 is the optional remote LCD keypad. It supports to copy, download, modify all the parameters and is easy to use. The structure and dimensions are as below.

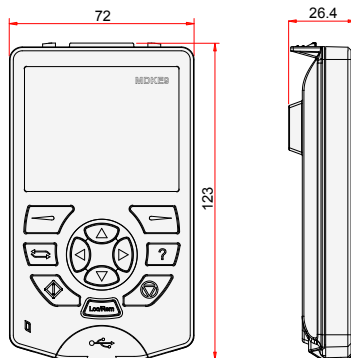

Figure 8-24 The mounting dimensions

Appendix A Expansion Optional Cards

The MD500E AC Drive supports abundant field buses, different types of encoders and custom programming via connection with the expansion optional cards.

This chapter introduces the optional cards installation guideline for MD38IO, MD38TX1 and PG cards. For other more information, please refer to the Advanced User Manual with MD500E.

A.1 Installation and Function Guidelines

A.1.1 Installation

The MD500E AC Drive supports two types I/O cards, one type PC programming card, four types field bus cards (Modbus-RTU, Profibus-DP2, CANLink, CANOpen) and seven types PG cards. Please remove the front cover before installation, and refer to chapter 3.1.5 for the details.

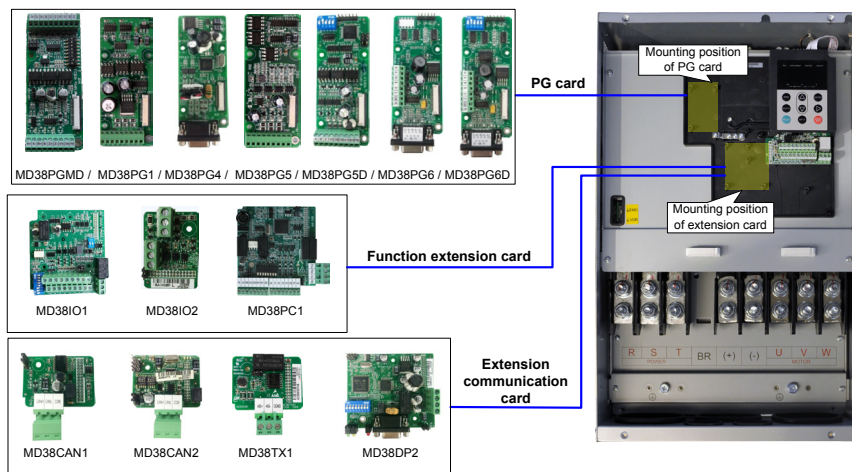

Figure A-1 Mounting positions of extension cards

A.1.2 Functions

Table A-1 Functions of extension cards

Model	Name	Function	Frequency Dividing Coefficient	Applicable Model
MD38IO1	Multi-functional I/O extension card	Provides the following: Five extra DI terminals An analog input. A relay output A digital output An analog output Supports Modbus-RTU Supports CANlink	-	Available for models of 15 kW or above
MD38IO2	Mini-I/O extension card	Provides three extra DI terminals.	-	Available for all models
MD38PC1	User programmable card	User-programmable extension card, completely compatible with the Inovance H1U series PLC.	-	Available for all models
MD38CAN1	CANlink communication card	Supports CANlink	-	Available for all models
MD38CAN2	CANopen communication card	Supports CANopen	-	Available for all models
MD38TX1	RS-485 communication extension card	Supports Modbus-RTU	-	Available for all models
MD38DP2	Profibus-DP2 communication card	Supports Profibus-DP2	-	Available for all models

A.2 Layout and Function of Terminals of Extension RS485 Card (MD38TX1)

MD38TX1 is specially designed to provide the drive with RS485 communication function. It adopts isolation scheme and electrical parameters conforming to international standards. It helps to implement control of drive running and parameter setting through remote serial interface.

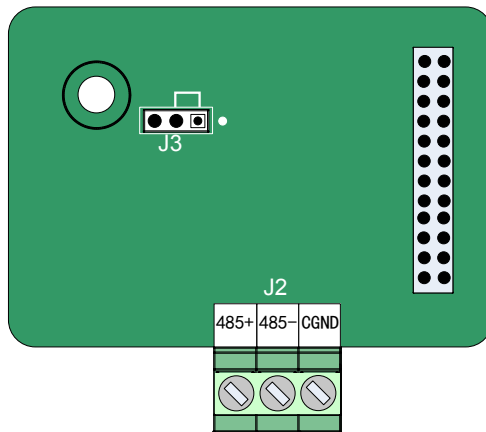

Figure A-2 Layout of MD38TX1 terminals

Table A-2 Terminal descriptions of MD38TX1

Terminal	Terminal Name	Function Description	Terminal Arrangement
J2	485+	RS485 positive input	
	485-	RS485 negative input	
	CGND	RS485 Power ground	

Table A-3 Jumper descriptions of MD38TX1

Terminal	Terminal Name	Function Description	Jumper
J3	RS485 terminal resistor matching selection	Matching terminal resistor	
		Not matching terminal resistor	

Note

- Setting of jumpers takes top view with main terminals at the bottom of the card as visual angle. Jumpers are silk-screened on the card.

A.3 Layout and Function of Terminals of MD38IO1

MD38IO1 is a multifunctional I/O extension card designed for Inovance AC drives. It has five digital input (DI) terminals, an analog input (AI) terminal, a relay output terminal, a digital output (DO) terminal and an analog output (AO) terminal. It also has the RS485 communication interface and CAN communication interface for field bus control.

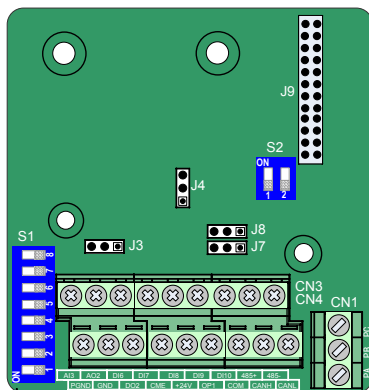

Figure A-3 Layout of MD38IO1 terminals

Table A-4 Terminal descriptions of MD38IO1







Terminal	Terminal Name	Function Description	Terminal Arrangement
CN4	+24V/COM	External +24 VDC power supply 1. Provide +24 V power supply to an external unit. Generally used for power supply for DI/DO terminals and external sensors. 2. Max. output current: 200 mA	
	OP1	Digital input power terminal 1. Connect to +24V by the jumper J8 by default. 2. When applying an external power supply, remove the jumper J8 and connect the OP1 to the external power supply.	
	DO2-CME	Digital output 2 1. Optically-coupled isolation, dual-polarity open-collector output 2. Output voltage range: 0 to 24 V 3. Output current range: 0 to 50 mA Note that CME1 and COM are internally insulated, but are shorted by jumper J7 internally. Remove the jumper if you need to apply an external power to DO2.	
	CANH/ CANL/COM	Communication interface CANlink communication input terminal, isolated input	
CN3	AI3-PGND	Analog input 3 1. Optically-coupled isolation input, supporting differential voltage input and temperature detection resistance input 2. Input voltage range: -10 to 10 VDC 3. PT100 and PT1000 temperature sensors 4. Input mode determined by DIP switch S1, multiple functions not supported simultaneously	
	AO2-GND	Analog output 2 1. Output voltage range: 0 to 10 V 2. Output current range: 0 to 20 mA 3. Output current with resistance range: 0 to 500 Ω	
	DI6-OP1 to DI10-OP1	Five digit inputs 1. Optically-coupled isolation compatible with dual-polarity inputs 2. Input impedance: 2.4 kΩ 3. Voltage range for inputs: 9 to 30 V	
	485+/485-/ COM	Communication interface Modbus-RTU communication input and output terminal, isolated input	
CN1	PA-PB	Normally-closed (NC) terminal Contact driving capacity: 250 VAC, 3 A, COSφ=0.4.	
	PA-PC	Normally-open (NO) terminal 30 VDC, 1 A	
Note		<ul style="list-style-type: none"> RS485 communication terminals 485+/485-/COM and CANlink communication terminals CANH/ CANL/COM are completely independent and can be used simultaneously. 	

Table A-5 Jumper descriptions of MD38IO1

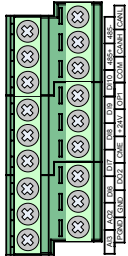
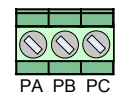
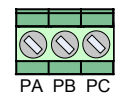
Terminal	Terminal Name	Function Description	Jumper
J3	AO2 output selection: voltage or current	Voltage: 0 V to 10 V	
		Current: 0 mA to 20 mA	
J4	CAN terminal resistor matching selection	Matching terminal resistor	
		Not matching terminal resistor	
S2	RS485 terminal resistor matching selection	1 and 2 set to ON: matching terminal resistor	
		1 and 2 set to OFF: not matching terminal resistor	
S1	AI, PT100, PT1000 selection	AI3: 1, 2, 3 set to ON	
		PT1000: 4, 5, 6 set to ON	
		PT100: 6, 7, 8 set to ON	
Note	<ul style="list-style-type: none"> Setting of jumpers takes top view with main terminals at the bottom of the card as visual angle. Jumpers are silk-screened on the card. 		

A.4 Layout and Function of Terminals of MD381O2

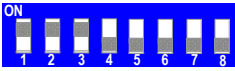
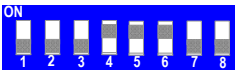
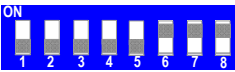
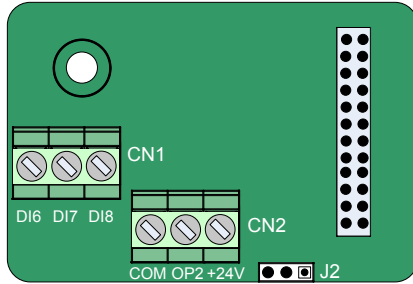

Figure A-4 Layout of MD381O2 terminals

Table A-6 Terminal descriptions of MD381O2



Terminal		Terminal Name	Function Description	Terminal Arrangement
CN2	+24V/COM	External +24 VDC power supply	1. Provide +24 V power supply to an external unit. Generally used for power supply for DI/DO terminals and external sensors. 2. Max. output current: 200 mA	 COM OP2 +24V
	OP2	Digital input power terminal	It is not connected to power supply by default. It can be connected either to external power or +24V according to the actual need.	
CN1	DI6-OP2 to DI8-OP2	Three digit inputs	1. Optically-coupled isolation compatible with dual-polarity inputs Input resistance: 3.3 kΩ for DI6 and DI7, 2.4 kΩ for DI8 3. Voltage range for inputs: 9 to 30 V 4. DI6, DI7 and DI8 are common input terminals with input frequency < 100 Hz.	 DI6 DI7 DI8

Table A-7 Jumper descriptions of MD381O2

Terminal	Terminal Name	Function Description	Jumper
J2	OP2 connecting mode selection	If DI connected in DRAIN mode, OP2 connected to +24V	
		If DI connected in SOURCE mode, OP2 connected to COM	

Note

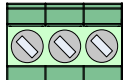
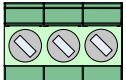
- Setting of jumpers takes top view with main terminals at the bottom of the card as visual angle. Jumpers are silk-screened on the card.

A.5 Use of Extension Encoder Cards

A.5.1 Specifications of Extension Encoder Cards

MD38PG1

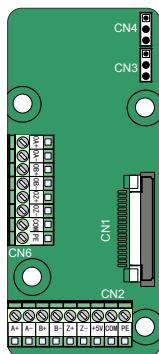

MD38PG1 Specification	
User interface	Oblique terminal block
Clearance	3.5 mm
Screw	Flathead
Pluggable	No
Cable specification	16-26AWG
Max. frequency	500kHz
Differential input limit	≤ 7 V
Frequency dividing	1:1

MD38PGMD

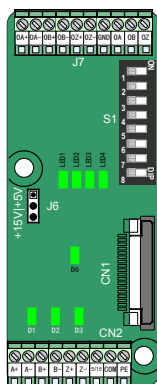

MD38PGMD Specification	
Encoder power supply	5 V/200 mA, 15 V/100 mA
Max. frequency	Differential: 500 kHz; Open-collector: 100 kHz
Encoder interface type	Differential, open-collector, push-pull
Frequency dividing interface type	Support differential, open-collector
Cable specification	16 to 26 AWG For the details, see section A.3.2.
Clearance	3.5 mm
Screw	Flathead
User interface	Oblique terminal block
Frequency dividing	0 to 63

MD38PG5

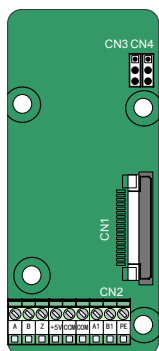

MD38PG5 Specification	
User interface	Oblique terminal block
Clearance	3.5 mm
Screw	Flathead
Pluggable	No
Cable specification	16-26AWG
Max. frequency	100kHz
Frequency dividing	1:1

MD38PG5D

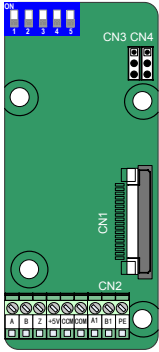

MD38PG5D Specification	
User interface	Oblique terminal block
Clearance	3.5 mm
Screw	Flathead
Pluggable	No
Cable specification	16-26 AWG
Max. frequency	100kHz
Frequency dividing	2 to 62 (even number)

MD38PG4

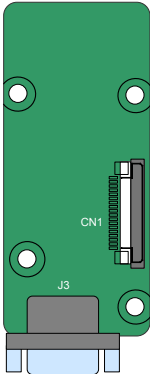

MD38PG4 Specification	
User interface	DB9 female plug
Pluggable	Yes
Cable specification	> 22AWG
Resolution	12-bit
Excitation frequency	10kHz
VRMS	7V
VP-P	3.15±27%
Frequency dividing	Without frequency dividing function

MD38PG6

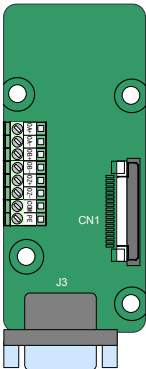

MD38PG6 Specification	
User interface J3	DB9 female plug
Pluggable	Yes
Cable specification	> 22 AWG
Max. frequency	500kHz
Differential input limit	≤ 7 V
User interface J7, J8	Oblique terminal block
Clearance	3.5 mm
Screw	Flathead
Pluggable	No
Frequency dividing rate	500kHz
Frequency dividing	1:1

MD38PG6D

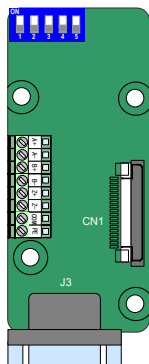

MD38PG6D Specification	
User interface J3	DB9 female plug
Pluggable	Yes
Cable specification	> 22 AWG
Max. frequency	500kHz
Differential input limit	≤ 7 V
User interface J7, J8	Oblique terminal block
Clearance	3.5 mm
Screw	Flathead
Pluggable	No
Frequency dividing rate	500kHz
Frequency dividing	2 to 62 (even number)

A.5.2 Multifunction PG Card (MD38PGMD)

Table A-8 Terminal descriptions of MD38PGMD



Terminal	Function Description	Terminal Arrangement	
CN2	A+	Encoder output signal A positive	
	A-	Encoder output signal A negative	
	B+	Encoder output signal B positive	
	B-	Encoder output signal B negative	
	Z+	Encoder output signal Z positive	
	Z-	Encoder output signal Z negative	
	5V/15V	Encoder 5V/15V power supply	
	COM	Encoder power ground	
PE	Shield connecting point		
J7	OA+	Differential frequency dividing output signal A positive	
	OA-	Differential frequency dividing output signal A negative	
	OB+	Differential frequency dividing output signal B positive	
	OB-	Differential frequency dividing output signal B negative	
	OZ+	Differential frequency dividing output signal Z positive	
	OZ-	Differential frequency dividing output signal Z negative	
	GND	Frequency dividing output reference ground	
	OA	Open-collector frequency dividing output signal A	
	OB	Open-collector frequency dividing output signal B	
	OZ	Open-collector frequency dividing output signal Z	
CN1	18-pin FFC interface, connecting to J4 on the control board of the AC drive		

Table A-9 Descriptions of DIP Switch of MD38PGMD

Filter Selection		Definition	Address setting						Value	Frequency Dividing Coefficient	DIP Switch
8	7		6	5	4	3	2	1			
0	0	Non-self-adaptive filter	0	0	0	0	0	0	Reserved	No output	
			0	0	0	0	0	1	1	Frequency divided by 1	
0	1	Self-adaptive filter	0	0	0	0	1	0	2	Frequency divided by 2	
			0	0	0	0	1	1	3	Frequency divided by 3	
1	0	Fixed inter-lock	...						61	Frequency divided by 61	
1	1	Automatic inter-lock	1	1	1	1	1	0	62	Frequency divided by 62	
			1	1	1	1	1	1	63	Frequency divided by 63	

Table A-10 Indicators of MD38PGMD

Indicator	State	Indication
D1/D2/D3 Encoder input signal indicator		ON or flash: The encoder has signal input.
		OFF: The encoder does not have signal input.
D6 Power supply indicator		ON: Normal.
		OFF: Power is not connected.
LED1 Encoder input signal quality indicator		OFF: Input signal is normal, speed is stable and there is no interference.
		ON: Input signal is slightly instable, which occurs when motor accelerates/ decelerates or encoder signal input suffers slight interference.
		Flash slowly: Input signal is moderately instable, which occurs when motor accelerates/ decelerates or encoder signal input suffers moderate interference.
		Flash quickly: Input signal is seriously instable, which occurs when motor accelerates/ decelerates quickly or encoder signal input suffers severe interference.
LED2 Signal processing quality indicator of PG card		OFF: Signal processing is normal, speed is stable and there is no interference.
		ON: Signal is slightly instable, which occurs when motor accelerates/ decelerates or interference during signal input is not completely filtered (The number of interference pulses that are not filtered is less than 10 per time unit).
		Flash slowly: Signal is moderately instable, which occurs when motor accelerates/ decelerates or interference during signal input is not completely filtered (The number of interference pulses that are not filtered is less than 30 per time unit).
		Flash quickly: Signal is seriously instable, which occurs when motor accelerates/ decelerates or interference during signal input is not completely filtered (The number of interference pulses that are not filtered is more than 30 per time unit).
LED3 Inter-lock state indicator		OFF: Inter-lock disabled.
		ON: Inter-lock enabled.

Indicator	State	Indication
LED4 System state indicator		OFF: The system is not operating or abnormal.
		Flash: The encoder cable breaks.
		ON: Normal.

A.5.3 Differential Input PG Card (MD38PG1)

Table A-11 Terminal descriptions of MD38PG1

Terminal	Function Description	Terminal Arrangement
CN2	A+	Encoder output signal A positive
	A-	Encoder output signal A negative
	B+	Encoder output signal B positive
	B-	Encoder output signal B negative
	Z+	Encoder output signal Z positive
	Z-	Encoder output signal Z negative
	5V	Encoder 5V/100mA power supply
	COM	Power ground
	PE	Shield connecting point
CN6	OA+	Encoder frequency dividing output signal A positive
	OA-	Encoder frequency dividing output signal A negative
	OB+	Encoder frequency dividing output signal B positive
	OB-	Encoder frequency dividing output signal B negative
	OZ+	Encoder frequency dividing output signal Z positive
	OZ-	Encoder frequency dividing output signal Z negative
	COM	Power ground
	PE	Shield connecting point
CN3, CN4	"pulse + direction" function	Supporting the "pulse + direction" function Pulse signal connected to phase A, direction signal connected to phase B
		Not supporting the "pulse + direction" function (default setting)
CN1	18-pin FFC interface, connecting to J4 on the control board of the AC drive	

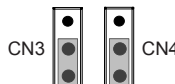
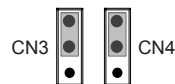
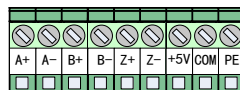

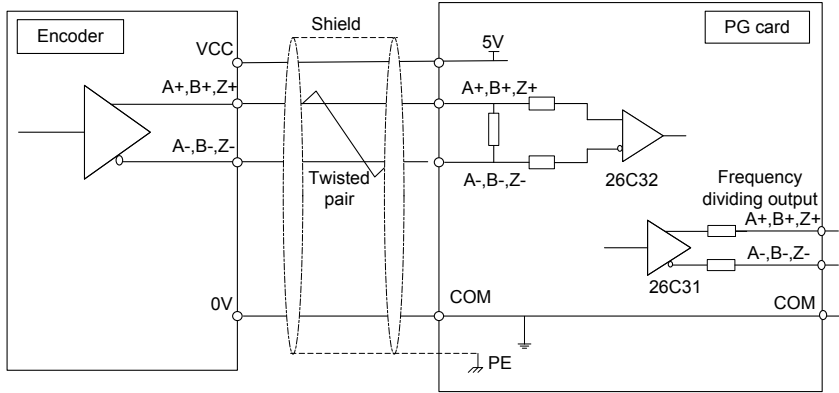

Figure A-5 Port circuit of MD38PG1

A.5.4 Resolver PG Card (MD38PG4)

Table A-12 Terminal descriptions of MD38PG4

Terminal	Pin	Definition	Function Description	Terminal Arrangement
J3	1	EXC1	Resolver excitation negative	
	2	EXC	Resolver excitation positive	
	3	SIN	Resolver feedback SIN positive	
	4	SINLO	Resolver feedback SIN negative	
	5	COS	Resolver feedback COS positive	
	6, 7, 8	NC	Vacant internally	
	9	COSLO	Resolver feedback COS positive	
CN1	18-pin FFC interface, connecting to J4 on the control board of the AC drive			

Table A-13 Indicators of MD38PG4

Indicator State	MD38PG4 Fault State	Description
	Normal	None
	Phase-lock loop unlocked	Phase lag of the resolver is very large.
	Signal SIN/COS amplitude exceeding the upper limit	D6 flashing is normally caused by interference. Ground the motor well and connect the ground point of the resolver card to PE of the drive.
	Signal SIN/COS amplitude too small	Generally, DB9 is not connected or wrongly connected, or even wire breaks. If the preceding conditions do not occur, check whether the resolver model selection is correct or not.

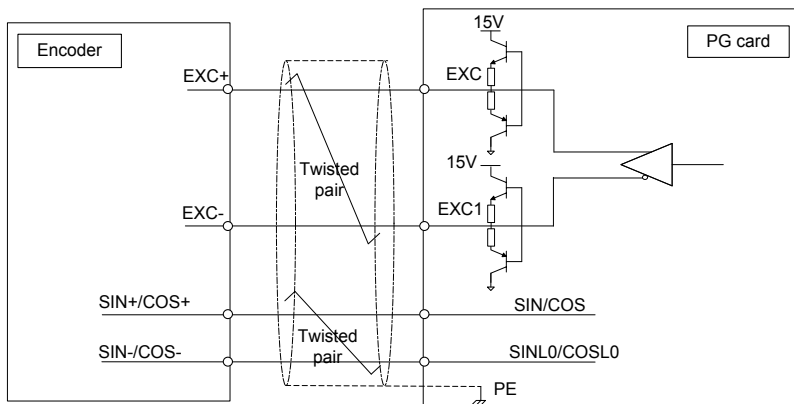

Figure A-6 Port circuit of MD38PG4

Note	<ul style="list-style-type: none"> Especially excited input DC resistance must be larger than 17 Ω (can be measured by a multimeter). Otherwise, MD38PG4 cannot work normally.
	<ul style="list-style-type: none"> It is suggested to select a resolver with a maximum of four pole-pairs. Otherwise, MD38PG4 will be overloaded.

A.5.5 Extension Open-collector PG Card (MD38PG5 and MD38PG5D)

Table A-14 Terminal descriptions of MD38PG5 and MD38PG5D

Terminal		Function Description	Terminal Arrangement
CN2	A	Encoder output signal A	
	B	Encoder output signal B	
	Z	Encoder output signal Z	
	15V	Encoder 15V/100mA power supply	
	COM	Power ground and frequency dividing output ground	
	COM	Power ground and frequency dividing output ground	
	A1	PG card frequency dividing output signal A (OC output, 0 to 24 V, 0 to 50 mA)	
	B1	PG card frequency dividing output signal B (OC output, 0 to 24 V, 0 to 50 mA)	
	PE	Shield connecting point	
CN3 CN4	"pulse + direction" function	Supporting the "pulse + direction" function Pulse signal connected to phase A, direction signal connected to phase B	
		Not supporting the "pulse + direction" function (default setting)	
CN1	18-pin FFC interface, connecting to J4 on the control board of the AC drive		

Table A-15 Descriptions of DIP Switch of MD38PG5D

DIP Switch Setting					Value	Frequency Dividing Coefficient	DIP Switch
1	2	3	4	5			
0	0	0	0	0	0	No output	
0	0	0	0	1	1	No output	
0	0	0	1	0	2	Frequency divided by 4	
0	0	0	1	1	3	Frequency divided by 6	
...							
1	1	1	1	1	31	Frequency divided by 62	

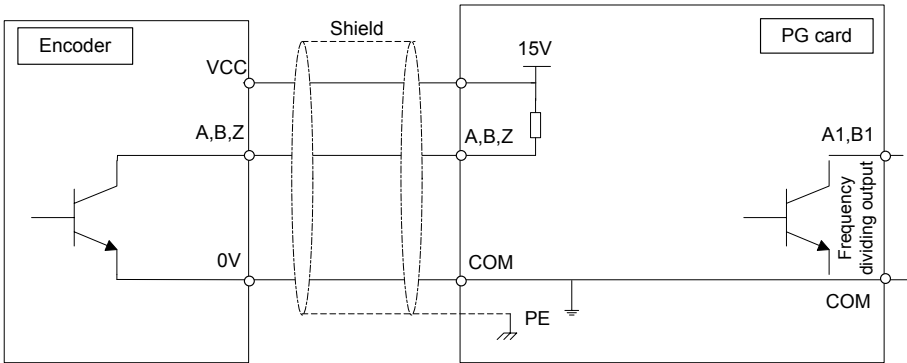

Figure A-7 Port circuit of MD38PG5 and MD38PG5D

A.5.6 Extension Differential PG Card with Frequency Dividing (MD38PG6 and MD38PG6D)

Table A-16 Terminal descriptions of MD38PG6 and MD38PG6D

Terminal	Pin	Definition	Function Description	Terminal Arrangement
J3	1	A+	Encoder signal A positive	
	2	A-	Encoder signal A negative	
	3	B+	Encoder signal B positive	
	4	B-	Encoder signal B negative	
	5	Z+	Encoder signal Z positive	
	6	Null	Vacant internally	
	7	+5V	Encoder 5V power supply positive	
	8	COM	Encoder power supply negative	
	9	Z-	Encoder signal Z negative	
J7, J8	OA+	Frequency dividing output signal A positive		
	OA-	Frequency dividing output signal A negative		
	OB+	Frequency dividing output signal B positive		
	OB-	Frequency dividing output signal B negative		
	OZ+	Frequency dividing output signal Z positive		
	OZ-	Frequency dividing output signal Z negative		
	COM	Signal power ground		
	PE	Shield connecting point		
CN1	18-pin FFC interface, connecting to J4 on the control board of the AC drive			

Table A-17 Descriptions of DIP Switch of MD38PG6D

DIP Switch Setting					Value	Frequency Dividing Coefficient	DIP Switch
1	2	3	4	5			
0	0	0	0	0	0	No output	
0	0	0	0	1	1	No output	
0	0	0	1	0	2	4	
0	0	0	1	1	3	6	
...					
1	1	1	1	1	31	62	

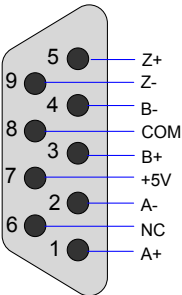
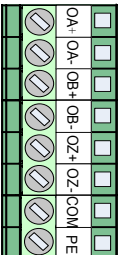
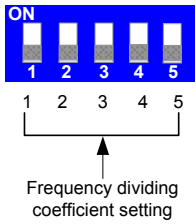
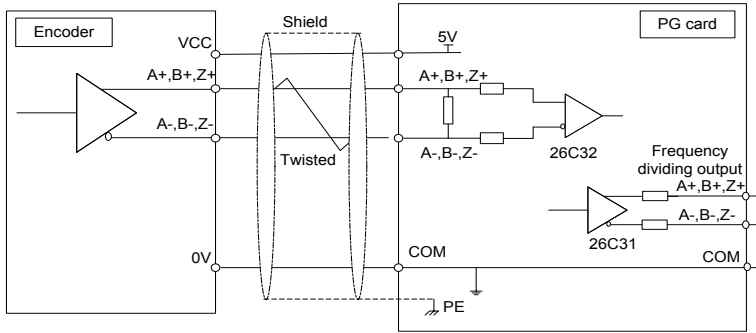
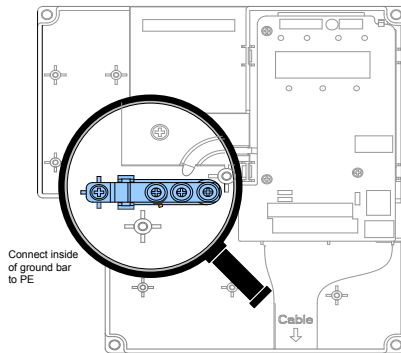

Figure A-8 Port circuit of MD38PG6 and MD38PG6D

A.5.7 Shield Grounding of PG Card

On prerequisite that AC drive parameters are set properly, if PG card feedback speed or position is instable, it indicates that the PG card suffers electromagnetic interference. In this case, connect shield of encoder signal lines to PE of the AC drive to restrain interference.



MD500E is wholly grounded. After installation of the PG card is done, PE of PG card is auto-connected to Ground signal with AC drive. When connecting encoder, connect shield of signal lines to PE of PG card to complete the shield grounding.

To install the PG card, remove the screw in amplified position and align mounting holes of the PG card to the four fixing pins and fix the PG card with the prepared M3 x 8 screws.

A.5.8 EMC Guidance

1. Do not bundle the encoder cable and power cables together. Failure to comply will result in the encoder interference.
2. Motor shell must be connected to PE of the AC drive. Meanwhile, connect the grounding cable of the motor to the motor shell reliably. Failure to comply will result in poor grounding effect.
3. An STP cable is suggested. For differential encoders, perform cable connection based on differential pairs properly and connect shield to PE of the AC drive.
4. For large equipment applications where the AC drive is far away from the motor and the motor cable is longer than 10 m, grounding effect is not good due to influence of cable inductance. In this case, encoder shield need not be connected to PE of the AC drive.
5. Indicators on the PG card indicate interference on MD38PGMD. For details, refer to description on indicators above.

Appendix B Definition of Communication Data Address and Modbus Communication Protocol

B.1 Definition of Communication Data Address

The drive supports four communication protocols (Modbus-RTU, CANopen, CANlink, and PROFIBUS-DP2). The host computer can implement control such as monitoring and parameter viewing and modification on the AC drive through their protocols.

The drive's communication data is classified into parameter data and non-parameter data. The non-parameter data includes running commands, running status, running parameters and alarm information.

B.1.1 Parameter Data

The parameter data provides important parameters of the AC drive. In addition to function parameter group F of MD320, MD500E provides the function parameter group A.

The parameter data is described as below:

MD500E Parameter Data	Group F (read-write)	F0, F1, F2, F3, F4, F5, F6, F7, F8, F9, FA, FB, FC, FD, FE, and FF
	Group A (read-write)	A0, A1, A2, A3, A4, A5, A6, A7, A8, A9, AA, AB, AC, AD, AE, and AF

Communication addresses of parameter data are defined as follows:

1. Read Function code by communication

For groups F0 to FF and A0 to AF, the high 16 bits of the communication address indicate the group number and the low 16 bits indicate the parameter number in the group.

Example: Communication address of F0-16 is F010H, where F0H represents group F0 and 10H is the hexadecimal data format of serial number 16 in the group.

Communication address of AC-08 is AC08H, where ACH represents group AC and 08H is the hexadecimal data format of serial number 8 in the group.

2. Write Function code by communication

For groups F0 to FF, whether the high 16 bits in communication address are 00 to 0F or F0 to FF is decided by whether the high 16 bits are written to EEPROM. The low 16 bits indicate parameter number in the group. Example:

F0-16:

If it needs not be written to EEPROM, communication address is 0010H.

If it needs to be written to EEPROM, communication address is F010H.

For groups A0 to AF, whether the high 16 bits in communication address are 40 to 0F or A0 to AF is decided by whether the high 16 bits are written to EEPROM. The low 16 bits indicate parameter number in the group. Example:

AC-08:

If it needs not be written to EEPROM, communication address is 4C08H.

If it needs to be written to EEPROM, communication address is AC08H.

B.1.2 Non-parameter Data

MD500E Non-parameter Data	Status data (read-only)	Group U (monitoring parameters), AC drive fault information and AC drive running status
	Control parameters (write-only)	Control commands, communication setting values, DO control, AO1 control, AO2 control, high-speed pulse (FMP) output control and parameter initialization

1. Status Data

Status data includes group U (monitoring parameters), AC drive fault description and AC drive running status.

Group U (monitoring parameters):

For details about Group U, refer to Appendix C of this manual. The communication address is as follows:

The high 16 bits in communication address of U0 to UF is 70 to 7F and the low 16 bits indicate the function code number in the group. For example, the communication address of U0-11 is 700BH.

AC drive fault description:

Communication address of the drive fault information is 8000H. You can obtain current fault codes by using host computer to read the address. For fault codes, refer to definition of F9-14 in Appendix C of this manual

AC drive running status:

When the drive running status is read via communication, the communication address is 3000H. You can obtain current running status information of the AC drive by reading the address. The running status is defined in the following table.

Communication Address of AC Drive's Running Status	Status Definition
3000H	1: Forward run
	2: Reverse run
	3: Stop

2. Control Parameters

The control parameters include control command, communication setting values, DO control, AO1 control, AO2 control, high-speed pulse (FMP) output control and parameter initialization.

■ Control commands

When F0-02 (command source selection) is set to 2 (communication control), you can implement control such as start/stop of the AC drive by using communication address. The control commands are defined in the following table.

Control Command Communication Address	Status Definition
2000H	1: Forward run
	2: Reverse run
	3: Forward jog
	4: Reverse jog
	5: Coast to stop
	6: Decelerate to stop
	7: Fault reset

■ Communication reference

Communication setting values include data set via communication such as frequency reference, torque limit, V/F separation voltage, PID reference and PID feedback. Communication address is 1000H. When the communication address is set in the host computer, the data range is -10000–10000 and corresponding relative set value range is -100.00% to 100.00%.

■ DO control

When a DO terminal is set for function 20 (communication control), host computer can implement control on DO terminals of the drive through the communication address. Control on DO terminals of the drive is defined as follows:

Communication Address of Drive Running Status	Command Content
2001H	BIT0: DO1 output control BIT1: DO2 output control BIT2: Relay1 output control BIT3: Relay2 output control BIT4: FMR output control BIT5: VDO1 BIT6: VDO2 BIT7: VDO3 BIT8: VDO4 BIT9: VDO5

■ Analog output AO1, AO2, high-speed pulse (FMP) output control

When AO1, AO2 and FMP are set to function 12 (communication control), host computer can implement control on AO and high-speed pulse outputs by means of communication addresses. The definition is provided in the following table.

Communication Address of AO1, AO2 and FMP Output		Command Content
AO1	2002H	0 to 7FFF indicates 0% to 100%.
AO2	2003H	
FMP	2004H	

■ Parameter initialization

This function is required when you need to perform parameter initialization on the drive by using the host computer.

If FP-00 (User password) is set to a non-zero value, pass password verification first. The host computer performs parameter initialization within 30s after password verification is successful.

Communication address of password verification via communication is 1F00H. Directly write correct user password to this address to perform password verification.

Communication address of parameter initialization by means of communication is 1F01H, defined in the following table.

Communication Address of Parameter Initialization	Status Definition
1F01H	1: Restore default settings
	2: Clear records
	4: Restore user backup parameters
	501: Back up current user parameters

B.2 Modbus Communication Protocol

The drive provides RS485 communication interface and supports Modbus-RTU slave communication protocol so that the user can implement centralized control, such as setting running commands and function codes, and reading running status and fault information of the AC drive, by using a PC or PLC.

This protocol defines content and format of transmitted messages during serial communication, including master polling (or broadcasting) format and master coding method (function code for the action, transmission data, and error check). The slave uses the same structure in response, including action confirmation, data returning and error check. If an error occurs when the slave receives a message, or the slave cannot complete the action required by the master, the slave returns a fault message as a response to the master.

B.2.1 Application

The AC drive is connected to a "single-master multi-slave" PC/PLC control network with RS485 bus.

B.2.2 Bus Structure

1. Interface mode

The RS485 extension card MD38TX1 must be inserted into the AC drive.

2. Topological structure

The system consists of a single master and multiple slaves. In the network, each communication device has a unique slave address. A device is the master (can be a PC, a PLC or an HMI) and initiates communication to perform parameter read or write operations on slaves. The other devices (slaves) provide data to respond to query or operations from the master. At the same moment, either the master or the slave transmits data and the other can only receives data.

The address range of the slaves is 1 to 247, and 0 is broadcast address. A slave address must be unique in the network.

3. Transmission mode

The asynchronous serial and half-duplex transmission mode is used. During asynchronous serial communication, data is sent frame by frame in the form of message. In Modbus-RTU protocol, an interval of at least 3.5-byte time marks the end of the previous message. A new message starts to be sent after this interval.

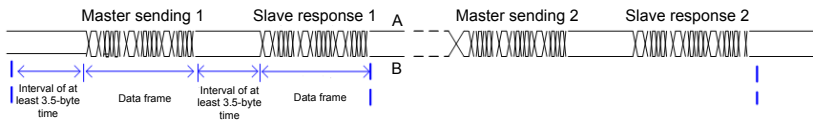

The communication protocol used by the drive is the Modbus-RTU slave communication protocol, which allows the drive to provide data to respond to "query/command" from the master or execute the action according to "query/command" from the master.

The master can be a PC, an industrial device, or a PLC. The master can communicate with a single slave or send broadcast messages to all slaves. When the master communicates with a single slave, the slave needs to return a message (response) to "query/command" from the master. For a broadcast message sent by the master, the slaves need not return a response.

B.3 Data Format

The Modbus-RTU protocol communication data format of the drive is as follows. The drive supports reading and writing of word-type parameters only. Reading command is 0x03 and writing command is 0x06. It does not support reading and writing of bytes or bits.

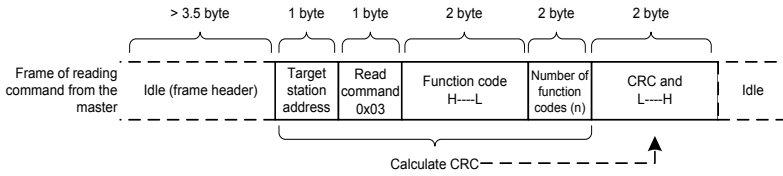

In theory, the host computer can read several consecutive parameters (n can reach up to 12) but the last parameter it reads must not jump to the next parameter group. Otherwise, an error occurs on response.

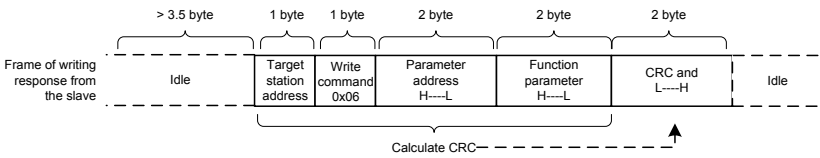
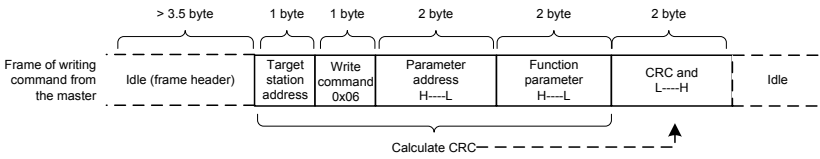
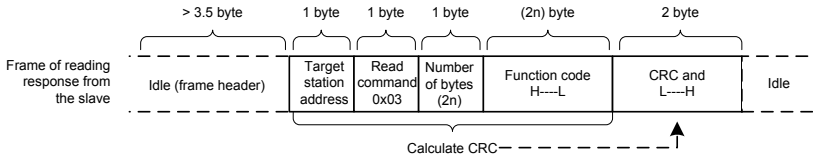

If the slave detects reading/writing failure caused by a communication frame error or by other reasons, an error frame will be returned.

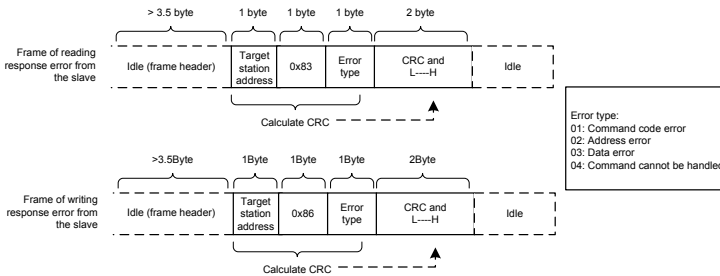

The frame format is described in the following table.

Frame header (START)	Greater than the 3.5-byte transmission idle time
Slave address (ADR)	Communication address: 1 to 247 0: Broadcast address
Command code (CMD)	03: Read slave parameters; 06: Write slave parameters
Function code address (H)	It is the internal parameter address of the AC drive, expressed in hexadecimal format. The parameters include functional parameters and non-functional parameters (running status and running command). During transmission, low-order bytes follow the high-order bytes.
Function code address (L)	
Number of function codes (H)	It is the number of function codes read by this frame. If it is 1, it indicates that one function code is read. During transmission, low-order bytes follow the high-order bytes. In the present protocol, only one function code is read once, and this field is unavailable.
Number of function codes (L)	
Data (H)	It is the response data or data to be written. During transmission, low-order bytes follow the high-order bytes.
Data (L)	
CRC CHK low bytes	Detection value: CRC16 verification value During transmission, low-order bytes follow the high-order bytes. For calculation method, refer to CRC Check.
CRC CHK high bytes	
END	It is 3.5-byte transmission time.

CRC Check

In Modbus-RTU mode, a message includes a CRC-based error-check field. The CRC field checks content of the entire message. The CRC field is two bytes, containing a 16-bit binary value. The CRC field is calculated by the transmitting device, and then added to message. The receiving device recalculates a CRC value after receiving the message, and compares the calculated value with the CRC value in the received CRC field. The CRC is first stored to 0xFFFF. Then a procedure is invoked to process the successive 8-bit byte in the message and the value in the register. Only the eight bits in each character are used for the CRC. The start bit, stop bit and the parity bit do not apply to the CRC. During generation of the CRC, each eight-bit character is in exclusive-OR (XOR) with the content in the register. Then the result is shifted in the direction of the least significant bit (LSB), with a zero filled into the most significant bit (MSB) position. The LSB is extracted and examined. If the LSB was a 1, the register then performs XOR with a preset value. If the LSB was a 0, no XOR is performed. This process is repeated until eight shifts have been performed. After the last (eighth) shift, the next eight-bit byte is in XOR with the register's current value, and the process repeats for eight more shifts as described above. The final value of the register, after all the bytes of the message have been applied, is the CRC value. The CRC is added to the message from the low-order byte followed by the high-order byte. The CRC simple function is as follows:

```

unsigned int crc_chk_value(unsigned char *data_value,unsigned char length)
{
    unsigned int crc_value=0xFFFF;
    int i;
    while (length--)
    {
        crc_value^=*data_value++;
        for (i=0;i<8;i++)
        {
            if(crc_value&0x0001)
            {
                crc_value=(crc_value>>1)^0xa001;
            }
            else
            {
                crc_value=crc_value>>1;
            }
        }
    }
    return(crc_value);
}

```

Definition of Communication Parameter Addresses

Function parameters can be read and written (except those which cannot be changed because they are only for the factory use or for monitoring).

B.4 Rules for Parameter Address Marking

Parameter group No. and parameter identifying No. are used to express parameter address.

High-order bytes: F0 to FF (groups F), A0 to AF (groups A), 70 to 7F (group U)

Low-order bytes: 00 to FF

For example, to read parameter F3-12, communication address of F3-12 is expressed as 0xF30C.

Note

- Group FF: They are factory parameters. The parameters cannot be read or changed.
- Group U: These parameters can only be read.

Some parameters cannot be modified when the AC drive is running. Some parameter cannot be modified regardless of status of the AC drive. In addition, pay attention to setting range, unit and description of parameters when modifying them.

Parameter Group	Visited Address	Parameter Address in RAM
F0 to FE	0xF000 to 0xFEFF	0x0000 to 0x0EFF
A0 to AC	0xA000 to 0xACFF	0x4000 to 0x4CFF
U0	0x7000 to 0x70FF	

Note

- Frequent storage to the EEPROM reduces its service life. Therefore, in communication mode, users can change values of certain parameters in RAM rather than storing the setting.

For groups F parameters, users only need to change high order F of the function code address to 0.

For groups A parameters, users only need to change high order A of the function code address to 4.

Appendix B

The function code addresses are expressed as follows:

High-order bytes: 00 to 0F (groups F), 40 to 4F (groups A)

Low-order bytes: 00 to FF

For example,

if function code F3-12 is not stored into EEPROM, the address is expressed as 030C;

if function code A0-05 is not stored into EEPROM, the address is expressed as 4005;

This address can only be marked as RAM. It is an invalid address when being read.

Stop/RUN Parameters

Parameter Address	Description	Parameter Address	Description
1000H	Communication setting value (Decimal): -10000 to 10000	1010H	PID reference
1001H	Running frequency	1011H	PID feedback
1002H	Bus voltage	1012H	PLC process
1003H	Output voltage	1013H	Pulse input frequency, unit: 0.01 kHz
1004H	Output current	1014H	Feedback speed, unit 0.1Hz
1005H	Output power	1015H	Remaining running time
1006H	Output torque	1016H	AI1 voltage before correction
1007H	Running speed	1017H	AI2 voltage before correction
1008H	DI input indication	1018H	AI3 voltage before correction
1009H	DO output indication	1019H	Linear speed
100AH	AI1 voltage	101AH	Current power-on time
100BH	AI2 voltage	101BH	Current running time
100CH	AI3 voltage	101CH	Pulse input frequency, unit: 1Hz
100DH	Counting value input	101DH	Communication reference
100EH	Length value input	101EH	Actual feedback speed
100FH	Load speed	101FH	Main frequency X display
-	-	1020H	Auxiliary frequency Y display

Note

- Communication setting value indicates percentage: 10000 corresponds to 100.00%, and -10000 corresponds to -100.00%.
- With regard to frequency, communication reference is a percentage of F0-10 (maximum frequency). With regard to torque, communication reference is a percentage of F2-10 and A2-48 (corresponding to motor 1 and motor 2, respectively).

Control command input to AC drive (write-only):

Command Word Address	Status Definition
2000H	0001: Forward run
	0002: Reverse run
	0003: Forward jog
	0004: Reverse jog
	0005: Coast to stop
	0006: Decelerate to stop
	0007: Fault reset

Read AC drive state (read-only):

Command Word Address	Command Word Function
3000H	0001: Forward run
	0002: Reverse run
	0003: Stop

Parameter lock password check: If the actual password is returned, it indicates that password check is passed. ("0000H" is returned when password is set to 0 (no password)).

Password Address	Password Content
1F00H	*****

DO terminal control (write-only)

Command Address	Command Content
2001H	BIT0: DO1 output control BIT1: DO2 output control BIT2: Relay1 output control BIT3: Relay2 output control BIT4: FMR output control BIT5: VDO1 BIT6: VDO2 BIT7: VDO3 BIT8: VDO4 BIT9: VDO5

AO1 control (write-only)

Command Address	Command Content
2002H	0 to 7FFF indicates 0% to 100%.

AO2 control (write-only)

Command Address	Command Content
2003H	0 to 7FFF indicates 0% to 100%.

Pulse output control (write-only)

Command Address	Command Content
2004H	0 to 7FFF indicates 0% to 100%.

AC drive fault description:

AC Drive Fault Address	AC Drive Fault Information	
8000H	0000: No fault 0001: Reserved 0002: Overcurrent during acceleration 0003: Overcurrent during deceleration 0004: Overcurrent at constant speed 0005: Overvoltage during acceleration 0006: Overvoltage during deceleration 0007: Overvoltage at constant speed 0008: Buffer resistor overload 0009: Undervoltage 000A: AC drive overload 000B: Motor overload 000C: Power input phase loss 000D: Power output phase loss 000E: IGBT overheat 000F: External fault 0010: Communication fault 0011: Contactor fault 0012: Current detection fault 0013: Motor auto-tuning fault 0014: Encoder/PG card fault	0015: Parameter read and write fault 0016: AC drive hardware fault 0017: Motor short circuited to ground 0018: Reserved 0019: Reserved 001A: Accumulative running time reached 001B: User-defined fault 1 001C: User-defined fault 2 001D: Accumulative power-on time reached 001E: Load lost 001F: PID feedback lost during running 0028: Fast current limit timeout 0029: Motor switchover error during running 002A: Too large speed deviation 002B: Motor over-speed 002D: Motor overheat 005A: Incorrect setting of PPR of the encoder 005B: Not connecting the encoder 005C: Initial position error 005E: Speed feedback error

B.5 Group FD Communication Parameter Description

Fd-00	Baud rate	Default	5005
	Setting Range	Units position (Modubs)	
		0: 300 bps	5: 9600 bps
		1: 600 bps	6: 19200 bps
		2: 1200bps	7: 38400 bps
		3: 2400 bps	8: 57600 bps
		4: 4800 bps	9: 115200 bps

This parameter is used to set transmission speed between host computer and AC drive. Note that baud rate of host computer must be the same as that of AC drive. Otherwise, communication shall fail. The higher baud rate is, the faster communication will be.

Fd-01	Data format	Default	0
	Setting Range	0: No check <8,N,2> 1: Even parity check <8,E,1> 2: Odd parity check <8,O,1> 3: No check, data format <8,N,1>	

Note that data format of host computer must be the same as that of AC drive. Otherwise, communication shall fail.

Fd-02	Local address	Default	1
	Setting Range	1 to 247 0: Broadcast address	

When local address is set to 0 (that is, broadcast address), host computer broadcast is enabled.

This address is unique (except broadcast address), which is basis for point-to-point communication between host computer and AC drive.

Fd-03	Response delay	Default	2 ms
	Setting Range	0 to 20 ms	

This parameter sets interval between AC drive completing receiving data and AC drive sending data to host computer. If response delay is shorter than system processing time, system processing time shall prevail. If response delay is longer than system processing time, system sends data to host computer only after response delay is up.

Fd-04	Communication timeout	Default	0.0s
	Setting Range	0.0s (invalid) 0.1s to 60.0s	

When this parameter is set to 0.0s, system does not detect communication timeout.

When AC drive does not receive communication signal within time set in this parameter, it detects communication timeout fault (Err16). Generally, this parameter is set to 0.0s. In applications with continuous communication, you can use this parameter to monitor communication status.

Fd-05	Communication Protocol Selection	Default	0
	Setting Range	0: Non-standard Modbus protocol 1: Standard Modbus protocol	

When Fd-05 = 1, standard Modbus protocol is used. For details, refer to B.3

When Fd-05 = 0, an additional byte is returned by the slave computer during read. For other read or write operations, the number of bytes returned is the same in both standard and non-standard protocols.

Fd-06	Current resolution read by communication	Default	0
	Setting Range	0: 0.01A 1: 0.1A	

This parameter is used to set unit of output current read by communication.

Appendix C Parameter Table

When a non-zero value is set for FP-00, the user-defined password is used. In function parameter mode and function parameter editing mode, enter the password correctly. To remove password protection, set FP-00 to 0.

The user password protection is used to protect operation on the panel. If this protection has been enabled, when you finish reading or writing parameters through the keypad and exit, you need to enter the password to get access again. Reading and writing are allowed without the password during communication operation (except FP and FF groups).

Password protection is not applicable to user-defined parameters.

Groups F and A include standard function parameters. Group U includes the monitoring function parameters. The symbols in the parameter table are described as follows:

☆ : It is possible to modify the parameter with the drive in the stop and in the Run status.

★ : It is not possible to modify the parameter with the drive in the Run status.

● : The parameter is the actual measured value and cannot be modified.

*: The parameter is a factory parameter and can be set only by the manufacturer.

C.1 Standard Parameter Table

Function Code	Name	Setting Range	Default	Change
Group F0: Standard Parameters				
F0-00	G/P type display	1: G (constant torque load) 2: P (fan an bump)	Model dependent	●
F0-01	Motor 1 control mode	0: SVC 1: FVC 2: V/F	0	★
F0-02	Command source selection	0: Operating panel 1: Terminal 2: Serial communication	0	☆
F0-03	Main frequency reference setting channel selection	0: Digital setting (revised value is not cleared after power off) 1: Digital setting (revised value is cleared after power off) 2: AI1 3: AI2 4: AI3 5: Pulse setting (DI5) 6: Multi-reference 7: Simple PLC 8: PID reference 9: Communication setting	0	★
F0-04	Auxiliary frequency reference setting channel selection	Same to F0-03	0	★
F0-05	Base value of range of auxiliary frequency reference for Main and auxiliary calculation	0: Relative to maximum frequency 1: Relative to main frequency reference	0	☆
F0-06	Range of auxiliary frequency reference for main and auxiliary calculation	0% to 150%	100%	☆

Appendix C

Function Code	Name	Setting Range	Default	Change
F0-07	Final Frequency reference setting selection	Units position: Frequency reference selection 0: Main frequency reference 1: Main and auxiliary calculation (based on tens position) 2: Switchover between main and auxiliary 3: Switchover between main and "main & auxiliary calculation" 4: Switchover between auxiliary and "main & auxiliary calculation" Tens position main and auxiliary calculation formula 0: Main + auxiliary 1: Main - auxiliary 2: Max. (main, auxiliary) 3: Min. (main, auxiliary)	00	☆
F0-08	Preset frequency	0.00 to max. frequency (F0-10)	50.00Hz	☆
F0-09	Running direction	0: Run in the default direction (FWD/REV indicator off) 1: Run in the direction reverse to the default direction (FWD/REV indicator on)	0	☆
F0-10	Max. frequency	5.00 Hz to 500.00 Hz	50.00Hz	★
F0-11	Setting channel of frequency upper limit	0: Set by F0-12 1: A11 2: A12 3: A13 4: Pulse reference 5: Communication reference	0	★
F0-12	Frequency reference upper limit	Frequency lower limit (F0-14) to max. frequency (F0-10)	50.00Hz	☆
F0-13	Frequency reference upper limit offset	0.00 Hz to max. frequency (F0-10)	0.00Hz	☆
F0-14	Frequency reference lower limit	0.00 Hz to frequency upper limit (F0-12)	0.00Hz	☆
F0-15	Carrier frequency	2.0 to 8.0 kHz	Model dependent	☆
F0-16	Carrier frequency adjusted with temperature	0: Disabled 1: Enabled	1	☆
F0-17	Acceleration time 1	0.00s to 650.00s (F0-19 = 2) 0.0s to 6500.0s (F0-19 = 1) 0s to 65000s (F0-19 = 0)	Model dependent	☆
F0-18	Deceleration time 1	0.00s to 650.00s (F0-19 = 2) 0.0s to 6500.0s (F0-19 = 1) 0s to 65000s (F0-19 = 0)	Mode Independent	☆
F0-19	Acceleration/Deceleration time unit	0: 1s 1: 0.1s 2: 0.01s	1	★
F0-21	Frequency offset of Auxiliary frequency setting channel for main and auxiliary calculation	0.00 Hz to max. frequency (F0-10)	0.00Hz	☆
F0-22	Frequency reference resolution	2: 0.01 Hz	2	★
F0-23	Retentive of digital setting frequency upon stop	0: Not retentive 1: Retentive	0	☆
F0-24	Motor parameter group selection	0: Motor parameter group 1 1: Motor parameter group 2	0	★
F0-25	Acceleration/Deceleration time base frequency	0: Maximum frequency (F0-10) 1: Frequency reference 2: 100 Hz	0	★

Function Code	Name	Setting Range	Default	Change
F0-26	Base frequency for UP/ DOWN modification during running	0: Running frequency 1: Frequency reference	0	★
F0-27	Command source + frequency source	Units position: operating panel (keypad & display) + frequency reference setting channel 0: No function 1: Digital setting 2: AI1 3: AI2 4: AI3 5: Pulse reference (DI5) 6: Multi-reference 7: Simple PLC 8: PID reference 9: Serial communication Tens position: terminal I/O control + frequency reference setting channel Hundreds position: serial communication + frequency reference setting channel	0000	☆
F0-28	Serial port communication protocol	0: Modbus protocol 1: PROFIBUS-DP or CANopen protocol	0	★
Group F1: Motor 1 Parameters				
F1-00	Motor type selection	2: Permanent magnet synchronous motor	2	★
F1-01	Rated motor power	0.1 to 1000.0 kW	Model dependent	★
F1-02	Rated motor voltage	1 to 2000 V	Model dependent	★
F1-03	Rated motor current	0.01 to 655.35 A (AC drive power ≤ 55 kW) 0.1 to 6553.5 A (AC drive power > 55 kW)	Model dependent	★
F1-04	Rated motor frequency	0.01 Hz to max. frequency	Model dependent	★
F1-05	Rated motor speed	1 to 65535 RPM	Model dependent	★
F1-16	Stator resistance of synchronous motor	0.001 to 65.535 Ω (AC drive power ≤ 55 kW)	Auto- tuning parameter	★
		0.0001 to 6.5535 Ω (AC drive power > 55 kW)		
F1-17	D-axis inductance of synchronous motor	0.01 to 655.35 mH (AC drive power ≤ 55 kW)	Auto- tuning parameter	★
		0.001 to 65.535 mH (AC drive power > 55 kW)		
F1-18	Q-axis inductance of synchronous motor	0.01 to 655.35 mH (AC drive power ≤ 55 kW)	Auto- tuning parameter	★
		0.001 to 65.535 mH (AC drive power > 55 kW)		
F1-20	Counter electromotive force of synchronous motor	0.0V to 6553.5 V	Auto- tuning parameter	★
F1-27	Encoder pulses per revolution	1 to 65535	1024	★
F1-28	Encoder type	0: ABZ incremental encoder 1: UVW incremental encoder 2: Resolver 4: Wire-saving UVW encoder	0	★
F1-30	A/B phase sequence of ABZ incremental encoder	0: Forward 1: Reserve	0	★
F1-31	Encoder installation angle	0.0 to 359.9°	0.0°	★
F1-32	UVW phase sequence of UVW encoder	0: Forward 1: Reserve	1	★

Appendix C

Function Code	Name	Setting Range	Default	Change
F1-34	Number of pole pairs of resolver	1 to 65535	1	★
F1-36	Encoder wire-break fault detection time	0.0s: No detection 0.1s to 10.0s	0.0s	★
F1-37	Auto-tuning selection	00: No operation 1: Synchronous auto-tuning with load 2: Synchronous auto-tuning with no-load	00	★
Group F2: Vector Control Parameters of Motor 1				
F2-00	Speed loop proportional gain 1	1 to 100	20	☆
F2-01	Speed loop integral time 1	0.01s to 10.00s	0.50s	☆
F2-02	Switchover frequency 1	0.00 to F2-05	5.00Hz	☆
F2-03	Speed loop proportional gain 2	1 to 100	20	☆
F2-04	Speed loop integral time 2	0.01s to 10.00s	1.00s	☆
F2-05	Switchover frequency 2	F2-02 to maximum frequency	10.00 Hz	☆
F2-09	Torque limit source in speed control	0: F2-10 1: AI1 2: AI2 3: AI3 4: Pulse reference (DI5) 5: Serial comms. 6: Min. (AI1, AI2) 7: Max. (AI1, AI2) Full scale of 1-7 corresponds to F2-10.	0	☆
F2-10	Digital setting of torque limit in speed control	0.0% to 200.0%	150.0%	☆
F2-11	Torque limit source in speed control (regenerative)	0: F2-12 (electrical or regenerative) 1: AI 2: AI2 3: AI3 4: Pulse reference 5: Communication reference 6: Min. (AI1, AI2) 7: Max. (AI1, AI2) 8: F2-12 Full scale of 1-7 corresponds to F2-12.	0	☆
F2-12	Digital setting of torque limit in speed control (regenerative) Digital setting (regenerative)	0.0% to 200.0%	150.0%	☆
F2-13	Excitation adjustment proportional gain	0 to 60000	2000	☆
F2-14	Excitation adjustment integral gain	0 to 60000	1300	☆
F2-15	Torque adjustment proportional gain	0 to 60000	2000	☆
F2-16	Torque adjustment integral gain	0 to 60000	1300	☆
F2-18	flux weakening mode of synchronous motor	0, 1, 2	1	★
F2-19	flux weakening gain of synchronous motor	1 to 50	5	☆

Function Code	Name	Setting Range	Default	Change
F2-22	Regenerative power limit selection	0, 1	0	★
F2-23	Regenerative power limit	0% to 50%	5%	☆
F2-24	Initial position angle detection current of synchronous motor	80% to 180%	120%	☆
F2-25	Initial position angle detection of synchronous motor	0, 1, 2	0	☆
F2-27	Salient-pole rate adjustment gain of synchronous motor	50 to 500	100	☆
F2-28	MTPA control	0, 1	0	☆
F2-32	Z signal correction	0, 1	1	☆
F2-36	Low speed excitation current	30% to 80%	30%	☆
F2-37	Low speed frequency	0.8K to F0-15	1.5K	☆
F2-41	Synchronous motor electromechanical sensing current	30% to 120%	80%	☆
F2-43	Zero servo enabling	0 to 1	0	☆
F2-44	Switchover frequency	0.00 to F2-02	0.30Hz	☆
F2-45	Zero servo speed loop proportional gain	1 to 100	10	☆
F2-46	Zero servo speed loop integral time	0.01s to 10.00s	0.50s	☆
F2-49	No-auto-tuning mode	0, 1, 2	0	☆
F2-50	Online counter electromotive force calculation	0, 1	0	☆
Group F3: V/F Control Parameters				
F3-00	V/F curve setting	0: Linear V/F 1: Multi-point V/F 2: Square V/F 3: 1.2-power V/F 4: 1.4-power V/F 6: 1.6-power V/F 8: 1.8-power V/F 9: Reserved 10: V/F complete separation 11: V/F half separation	0	★
F3-01	Torque boost	0.0%: No torque boost 0.1 to 30.0 %	Model dependent	☆
F3-02	Cut-off frequency of torque boost	0.00 Hz to max. frequency	50.00Hz	★
F3-03	Multi-point V/F frequency 1	0.00 Hz to F3-05	0.00Hz	★
F3-04	Multi-point V/F voltage 1	0.0% to 100.0%	0.0%	★
F3-05	Multi-point V/F frequency 2	F3-03 to F3-07	0.00Hz	★
F3-06	Multi-point V/F voltage 2	0.0% to 100.0%	0.0%	★
F3-07	Multi-point V/F frequency 3	F3-05 to rated motor frequency F1-04, Hz	0.00Hz	★
F3-08	Multi-point V/F voltage 3	0.0% to 100.0%	0.0%	★
F3-10	V/F over-excitation gain	0 to 200	64	☆
F3-11	V/F oscillation suppression gain	0 to 100	40	☆

Appendix C

Function Code	Name	Setting Range	Default	Change
F3-13	Voltage source for V/F separation	0: Set by F3-14 1: AI1 2: AI2 3: AI3 4: Pulse reference (DI5) 5: Multi-reference 6: Simple PLC 7: PID reference 8: Serial comms. Note: 100.0% corresponds to the rated motor voltage	0	☆
F3-14	Digital setting of voltage for V/F separation	0 V to rated motor voltage	0V	☆
F3-15	Voltage rise time of V/F separation	0.0s to 1000.0s Note: It is the time used for the voltage increases from 0 V to the motor rated voltage.	0.0s	☆
F3-16	Voltage decline time of V/F separation	0.0s to 1000.0s Note: It is the time used for the voltage increases from 0 V to the motor rated voltage.	0.0s	☆
F3-17	Stop mode selection for V/F separation	0: Frequency and voltage declining to 0 independently 1: Frequency declining after voltage declines to 0	0	☆
F3-18	Current limit level	50% to 200%	150%	★
F3-19	Current limit selection	0: Disabled 1: Enabled	1 (Enabled)	★
F3-20	Current limit gain	0 to 100	20	☆
F3-21	Compensation factor of speed multiplying current limit	50% to 200%	50%	★
F3-22	Voltage limit	650.0 to 800.0 V	770.0V	★
F3-23	Voltage limit selection	0: Disabled 1: Enabled	1 (Enabled)	★
F3-24	Frequency gain for voltage limit	0 to 100	30	☆
F3-25	Voltage gain for voltage limit	0 to 100	30	☆
F3-26	Frequency rise threshold during voltage limit	0 to 50 Hz	5Hz	★

Function Code	Name	Setting Range	Default	Change
Group F4: Input Terminals				
F4-00	DI1 function selection	0: No function 1: Forward RUN (FWD) 2: Reverse RUN (REV) (Note: F4-11 shall be set when F4-00 is set to 1 or 2.) 3: Three-wire control	1	★
F4-01	DI2 function selection	4: Forward JOG (FJOG) 5: Reverse JOG (RJOG) 6: Terminal UP 7: Terminal DOWN 8: Coast to stop	4	★
F4-02	DI3 function selection	9: Fault reset (RESET) 10: RUN pause 11: External fault normally open (NO) input 12: Multi-reference terminal 1 13: Multi-reference terminal 2	9	★
F4-03	DI4 function selection	14: Multi-reference terminal 3 15: Multi-reference terminal 4 16: Terminal 1 for acceleration/deceleration time selection 17: Terminal 2 for acceleration/deceleration time selection 18: Frequency source switchover	12	★
F4-04	DI5 function selection	19: UP and DOWN setting clear (terminal, keypad) 20: Running command switchover terminal 1 21: Acceleration/Deceleration prohibited 22: PID pause 23: PLC status reset 24: Swing pause	13	★
F4-05	DI6 function selection	25: Counter input 26: Counter reset 27: Length count input 28: Length reset 29: Torque control prohibited 30: Pulse input (enabled only for DI5)	0	★
F4-06	DI7 function selection	31: Reserved 32: Immediate DC injection braking 33: External fault normally closed (NC) input 34: Frequency modification enabled 35: PID action direction reverse 36: External STOP terminal 1	0	★
F4-07	DI8 function selection	37: Running command switchover terminal 2 38: PID integral disabled 39: Switchover between main frequency source and preset frequency 40: Switchover between auxiliary frequency source and preset frequency 41: Motor terminal selection 42: Reserved	0	★
F4-08	DI9 function selection	43: PID parameter switchover 44: User-defined fault 1 45: User-defined fault 2 46: Speed control/Torque control switchover 47: Emergency stop 48: External STOP terminal 2 49: Deceleration DC injection braking 50: Clear the current running time	0	★
F4-09	DI10 function selection	51: Two-wire/Three-wire mode switchover 52: Reverse frequency forbidden 53-59: Reserved	0	★

Appendix C

Function Code	Name	Setting Range	Default	Change
F4-10	DI filter time	0.000s to 1.000s	0.010s	☆
F4-11	Terminal I/O control mode	0: Two-wire control mode 1 1: Two-wire control mode 2 2: Three-wire control mode 1 3: Three-wire control mode 2	0	★
F4-12	Terminal UP/DOWN rate	0.001 to 65.535 Hz/s	1.00 Hz/s	☆
F4-13	AI curve 1 min. input	0.00 V to F4-15	0.00V	☆
F4-14	Corresponding percentage of AI curve 1 min. input	-100.0% to +100.0%	0.0%	☆
F4-15	AI curve 1 max. input	F4-13 to +10.00 V	10.00V	☆
F4-16	Corresponding percentage of AI curve 1 max. input	-100.0% to +100.0%	100.0%	☆
F4-17	AI1 filter time	0.00s to 10.00s	0.10s	☆
F4-18	AI curve 2 min. input	0.00 V to F4-20	0.00V	☆
F4-19	Corresponding percentage of AI curve 2 min. input	-100.0% to +100.0%	0.0%	☆
F4-20	AI curve 2 max. input	F4-18 to 10.00 V	10.00V	☆
F4-21	Corresponding percentage of AI curve 2 max. input	-100.0% to +100.0%	100.0%	☆
F4-22	AI2 filter time	0.00s to 10.00s	0.10s	☆
F4-23	AI3 curve min. input	-10.00 V to F4-25	-10.00V	☆
F4-24	Corresponding percentage of AI curve 3 min. input	-100.0% to +100.0%	-100.0%	☆
F4-25	AI curve 3 max. input	F4-23 to +10.00 V	10.00V	☆
F4-26	Corresponding percentage of AI curve 3 max. input	-100.0% to +100.0%	100.0%	☆
F4-27	AI3 filter time	0.00s to 10.00s	0.10s	☆
F4-28	Pulse min. input	0.00 kHz to F4-30	0.00kHz	☆
F4-29	Corresponding percentage of pulse min. input	-100.0% to 100.0%	0.0%	☆
F4-30	Pulse max. input	F4-28 to 100.00 kHz	50.00kHz	☆
F4-31	Corresponding percentage of pulse max. input	-100.0% to 100.0%	100.0%	☆
F4-32	Pulse filter time	0.00s to 10.00s	0.10s	☆
F4-33	AI curve selection	Units position: AI1 curve selection 1: Curve 1 (2 points, see F4-13 to F4-16) 2: Curve 2 (2 points, see F4-18 to F4-21) 3: Curve 3 (2 points, see F4-23 to F4-26) 4: Curve 4 (4 points, see A6-00 to A6-07) 5: Curve 5 (4 points, see A6-08 to A6-15) Tens position: AI2 curve selection Hundreds position: AI3 curve selection	321	☆
F4-34	Setting selection when AI less than min. input	Units position: AI1 0: Corresponding percentage of min. input 1: 0.0% Tens position: AI2 Hundreds position: AI3	000	☆
F4-35	DI1 delay	0.0s to 3600.0s	0.0s	★
F4-36	DI2 delay	0.0s to 3600.0s	0.0s	★

Function Code	Name	Setting Range	Default	Change
F4-37	DI3 delay	0.0s to 3600.0s	0.0s	★
F4-38	DI active mode selection 1	0: High level active 1: Low level active Units position: DI1 active mode Tens position: DI2 active mode Hundreds position: DI3 active mode Thousand position: DI4 active mode Ten thousands position: DI5 active mode	00000	★
F4-39	DI active mode selection 2	0: High level active 1: Low level active Units position: DI6 active mode Tens position: DI7 active mode Hundreds position: DI8 active mode Thousand position: DI9 active mode Ten thousands position: DI10 active mode	00000	★
Group F5: Output Terminals				
F5-00	FM terminal output mode	0: Pulse output (FMP) 1: Digital output (FMR)	0	☆
F5-01	FMR function selection	0: No output 1: AC Drive running 2: Fault output (coast to stop) 3: Frequency-level detection FDT1 output 4: Frequency reached 5: Zero-speed running (no output at stop) 6: Motor overload pre-warning 7: AC drive overload pre-warning	0	☆
F5-02	Control board relay function selection (T/A-T/B-T/C)	8: Set count value reached 9: Designated count value reached 10: Length reached 11: PLC cycle completed 12: Accumulative running time reached 13: Frequency limited	2	☆
F5-03	Extension card relay (P/A-P/B-P/C) function selection	14: Torque limited 15: Ready for RUN 16: AI1 > AI2 17: Frequency upper limit reached 18: Frequency lower limit reached (no output at stop) 19: Undervoltage status output 20: Communication setting 21: Reserved	0	☆
F5-04	DO1 function selection	22: Reserved 23: Zero-speed running 2 (having output at stop) 24: Accumulative power-on time reached 25: Frequency level detection FDT2 output 26: Frequency 1 reached 27: Frequency 2 reached 28: Current 1 reached 29: Current 2 reached	1	☆
F5-05	Extension card DO2 function selection	30: Timing duration reached 31: AI1 input limit exceeded 32: Load lost 33: Reverse running 34: Zero current status 35: IGBT temperature reached 36: Software current limit exceeded 37: Frequency lower limit reached (having output at stop) 38: Alarm output 39: Motor overheat warning 40: Current running time reached 41: Fault output (no output at undervoltage)	4	☆

Appendix C

Function Code	Name	Setting Range	Default	Change
F5-06	FMP function selection	0: Running frequency 1: Set frequency 2: Output current 3: Output torque (absolute value, proportion to motor torque)	0	☆
F5-07	AO1 function selection	4: Output power 5: Output voltage 6: Pulse input (100.0% corresponds to 100.0 kHz) 7: AI1 8: AI2	0	☆
F5-08	AO2 function selection	9: AI3 (extension card) 10: Length 11: Count value 12: Communication setting 13: Motor rotational speed 14: Output current (100.0% corresponds to 1000.0 A) 15: Output voltage (100.0% corresponds to 1000.0 V) 16: Output torque (actual value, proportion to motor torque)	1	☆
F5-09	Max. FMP output frequency	0.01kHz to 100.00kHz	50.00kHz	☆
F5-10	AO1 zero offset coefficient	-100.0% to +100.0%	0.0%	☆
F5-11	AO1 gain	-10.00 to +10.00	1.00	☆
F5-12	AO2 zero offset coefficient	-100.0% to +100.0%	0.0%	☆
F5-13	AO2 gain	-10.00 to +10.00	1.00	☆
F5-17	FMR output delay	0.0s to 3600.0s	0.0s	☆
F5-18	Relay 1 output delay	0.0s to 3600.0s	0.0s	☆
F5-19	Relay 2 output delay	0.0s to 3600.0s	0.0s	☆
F5-20	DO1 output delay	0.0s to 3600.0s	0.0s	☆
F5-21	DO2 output delay	0.0s to 3600.0s	0.0s	☆
F5-22	Active mode selection of DO output terminals	0: Positive logic active 1: Negative logic active Units position: FMR active mode Tens position: Relay1 active mode Hundreds position: Relay2 active mode Thousands position: DO1 active mode Ten thousands position: DO2 active mode	00000	☆
Group F6: Start/Stop Control				
F6-00	Start mode	0: Direct start	0	☆
F6-03	Start frequency	0.00Hz to 10.00Hz	0.00Hz	☆
F6-04	Start frequency holding time	0.0s to 100.0s	0.0s	★
F6-07	Acceleration/Deceleration mode	0: Linear acceleration/deceleration 1: Static S-curve acceleration/deceleration 2: Dynamic S-curve acceleration/deceleration	0	★
F6-08	Time proportion of S-curve start segment	0.0% to (100.0% - F6-09)	30.0%	★
F6-09	Time proportion of S-curve end segment	0.0% to (100.0% - F6-08)	30.0%	★
F6-10	Stop mode	0: Decelerate to stop; 1: Coast to stop	0	☆
F6-15	Braking use ratio	0% to 100%	100%	☆
Group F7: Keypad Operation and LED Display				
F7-00	LED default display check	0 to 1	0	☆

Function Code	Name	Setting Range	Default	Change
F7-01	MF.K key function selection	0: MF.K key disabled 1: Switchover from remote control (terminal or communication) to keypad control 2: Switchover between forward rotation and reverse rotation 3: Forward jog 4: Reverse jog	0	★
F7-02	STOP/RESET key function	0: STOP/RESET key enabled only in keypad control 1: STOP/RESET key enabled in any operation mode	1	☆
F7-03	LED display running parameters 1	0000 to FFFF Bit00: Running frequency 1 (Hz) Bit01: Frequency reference (Hz) Bit02: Bus voltage (V) Bit03: Output voltage (V) Bit04: Output current (A) Bit05: Output power (kW) Bit06: Output torque (%) Bit07: DI state (V) Bit08: DO state Bit09: AI1 voltage (V) Bit10: AI2 voltage (V) Bit11: AI3 voltage (V) Bit12: Count value Bit13: Length value Bit14: Load speed display Bit15: PID reference	1F	☆
F7-04	LED display running parameters 2	0000 to FFFF Bit00: PID feedback Bit01: PLC stage Bit02: Pulse reference (kHz) Bit03: Running frequency 2 (Hz) Bit04: Remaining running time Bit05: AI1 voltage before correction (V) Bit06: AI2 voltage before correction (V) Bit07: AI3 voltage before correction (V) Bit08: Motor speed Bit09: Current power-on time (H) Bit10: Current running time (Min) Bit11: Pulse reference (Hz) Bit12: Communication reference Bit13: Encoder feedback speed (Hz) Bit14: Main frequency X display (Hz) Bit15: Auxiliary frequency Y display (Hz)	0	☆
F7-05	LED display stop parameters	0000 to FFFF Bit00: Frequency reference (Hz) Bit01: Bus voltage (V) Bit02: DI state Bit03: DO state Bit04: AI1 voltage (V) Bit05: AI2 voltage (V) Bit06: AI3 voltage (V) Bit07: Count value Bit08: Length value Bit09: PLC stage Bit10: Load speed Bit11: PID reference Bit12: Pulse reference (kHz)	0	☆

Appendix C

Function Code	Name	Setting Range	Default	Change
F7-06	Load speed display coefficient	0.0001 to 6.5000	1.0000	☆
F7-07	Heatsink temperature of AC Drive	-20°C to 120°C	-	●
F7-08	Product number	-	-	●
F7-09	Accumulative running time	0h to 65535 h	-	●
F7-10	Performance software version	-	-	●
F7-11	Function software version	-	-	●
F7-12	Number of decimal places for load speed display	Units position: Number of decimal places for U0-14 0: No decimal place 1: One decimal places 2: Two decimal places 3: Three decimal places Tens position: Number of decimal places of U0-19/U0-29 1: One decimal places 2: Two decimal places	21	☆
F7-13	Accumulative power-on time	0 to 65535 h	-	●
F7-14	Accumulative power consumption	0 to 65535 kWh	-	●
Group F8: Auxiliary Functions				
F8-00	Jog frequency reference	0.00 Hz to max. frequency	2.00Hz	☆
F8-01	Jog acceleration time	0.0s to 6500.0s	20.0s	☆
F8-02	Jog deceleration time	0.0s to 6500.0s	20.0s	☆
F8-03	Acceleration time 2	0.0s to 6500.0s	Model dependent	☆
F8-04	Deceleration time 2	0.0s to 6500.0s	Model dependent	☆
F8-05	Acceleration time 3	0.0s to 6500.0s	Model dependent	☆
F8-06	Deceleration time 3	0.0s to 6500.0s	Model dependent	☆
F8-07	Acceleration time 4	0.0s to 6500.0s	0.0s	☆
F8-08	Deceleration time 4	0.0s to 6500.0s	0.0s	☆
F8-09	Frequency jump 1	0.00 Hz to max. frequency	0.00Hz	☆
F8-10	Frequency jump 2	0.00 Hz to max. frequency	0.00Hz	☆
F8-11	Frequency jump band	0.00 Hz to max. frequency	0.00 Hz	☆
F8-12	Forward/Reverse run switchover dead-zone time	0.0s to 3000.0s	0.0s	☆
F8-13	Reverse RUN selection	0: Disabled 1: Enabled	0	☆
F8-14	Running mode when frequency reference lower than frequency lower limit	0: Run at frequency reference lower limit 1: Stop 2: Run at zero speed	0	☆
F8-15	Droop rate	0.00% to 100.00%	0.00%	☆
F8-16	Accumulative power-on time threshold	0 h to 65000 h	0h	☆
F8-17	Accumulative running time threshold	0 h to 65000 h	0h	☆
F8-18	Startup protection selection	0: Disabled 1: Enabled	0	☆
F8-19	Frequency detection value 1	0.00 Hz to max. frequency	50.00Hz	☆

Function Code	Name	Setting Range	Default	Change
F8-20	Frequency detection hysteresis 1	0.0% to 100.0% (FDT1 level)	5.0%	☆
F8-21	Detection width of target frequency reached	0.0% to 100.0% (maximum frequency)	0.0%	☆
F8-22	Jump frequency function	0: Disabled 1: Enabled	0	☆
F8-25	Switchover frequency of accel time 1 and accel time 2	0.00 Hz to max. frequency	0.00Hz	☆
F8-26	Switchover frequency of deceleration time 1 and deceleration time 2	0.00 Hz to max. frequency	0.00Hz	☆
F8-27	Set highest priority to terminal JOG function	0: Disabled 1: Enabled	0	☆
F8-28	Frequency detection value 2	0.00 Hz to max. frequency	50.00Hz	☆
F8-29	Frequency detection hysteresis 2	0.0% to 100.0% (FDT2 level)	5.0%	☆
F8-30	Detection of frequency 1	0.00 Hz to max. frequency	50.00Hz	☆
F8-31	Detection width of frequency 1	0.0% to 100.0% (maximum frequency)	0.0%	☆
F8-32	Detection of frequency 2	0.00 Hz to max. frequency	50.00Hz	☆
F8-33	Detection width of frequency 2	0.0% to 100.0% (maximum frequency)	0.0%	☆
F8-34	Zero current detection level	0.0% to 300.0% 100.0% corresponds to rated motor current.	5.0%	☆
F8-35	Zero current detection delay	0.01s to 600.00s	0.10s	☆
F8-36	Output overcurrent threshold	0.0% (no detection) 0.1% to 300.0% (rated motor current)	200.0%	☆
F8-37	Output overcurrent detection delay	0.00s to 600.00s	0.00s	☆
F8-38	Detection level of current 1	0.0% to 300.0% (rated motor current)	100.0%	☆
F8-39	Detection width of current 1	0.0% to 300.0% (rated motor current)	0.0%	☆
F8-40	Detection level of current 2	0.0% to 300.0% (rated motor current)	100.0%	☆
F8-41	Detection width of current 2	0.0% to 300.0% (rated motor current)	0.0%	☆
F8-42	Timing function	0: Disabled 1: Enabled	0	★
F8-43	Running time setting channel	0: Set by F8-44 1: AI1 2: AI2 3: AI3 (100% of analog input corresponds to the value of F8-44)	0	★
F8-44	Running time	0.0 Min to 6500.0 Min	0.0 Min	★
F8-45	AI1 input voltage lower limit	0.00 V to F8-46	3.10V	☆
F8-46	AI1 input voltage upper limit	F8-45 to 10.00 V	6.80V	☆
F8-47	IGBT temperature threshold	0°C to 100°C	75°C	☆
F8-48	Cooling fan working mode	0: Working during drive running 1: Working continuously	0	☆
F8-49	Wakeup frequency	Hibernating frequency (F8-51) to max. frequency (F0-10)	0.00Hz	☆

Appendix C

Function Code	Name	Setting Range	Default	Change
F8-50	Wakeup delay time	0.0s to 6500.0s	0.0s	☆
F8-51	Hibernating frequency	0.00 Hz to wakeup frequency (F8-49)	0.00Hz	☆
F8-52	Hibernating delay time	0.0s to 6500.0s	0.0s	☆
F8-53	Running time threshold this time	0.0 to 6500.0 min	0.0Min	☆
F8-54	Output power correction coefficient	0.00% to 200.0%	100.0%	☆
F8-57	Current correction coefficient	95% to 100%	100%	☆
Group F9: Fault and Protection				
F9-00	Motor overload protection	0: Disabled 1: Enabled	1	☆
F9-01	Motor overload protection gain	0.20 to 10.00	1.00	☆
F9-02	Motor overload pre-warning coefficient	50% to 100%	80%	☆
F9-03	Overvoltage protection gain	0 to 100	30	☆
F9-04	Overvoltage protection voltage	650 to 800 V	770V	☆
F9-07	Detection of short-circuit to ground upon power-on	Units position: Detection of short-circuit to ground upon power on 0: Disabled 1: Enabled Tens position: Detection of short-circuit to ground before running 0: Disabled 1: Enabled	01	☆
F9-08	Braking unit applied voltage	650 to 800 V	760V	★
F9-09	Auto reset times	0 to 20	0	☆
F9-10	Selection of DO action during auto reset	0: Not act 1: Act	0	☆
F9-11	Delay of auto reset	0.1s to 100.0s	1.0s	☆
F9-12	Input phase loss/pre-charge relay protection	Units position: Input phase loss protection Tens position: Pre-charge relay protection 0: Disabled 1: Enabled	11	☆
F9-13	Output phase loss protection	Units position: Output phase loss protection 0: Disabled 1: Enabled Tens position: Output phase loss protection before running 0: Disabled 1: Enabled	01	☆

Function Code	Name	Setting Range	Default	Change
F9-14	1st fault type	0: No fault 1: Reserved 2: Overcurrent during acceleration 3: Overcurrent during deceleration 4: Overcurrent at constant speed 5: Overvoltage during acceleration 6: Overvoltage during deceleration 7: Overvoltage at constant speed 8: Buffer resistor overload 9: Undervoltage 10: AC drive overload 11: Motor overload 12: Power input phase loss	-	●
F9-15	2nd fault type	13: Power output phase loss 14: IGBT overheat 15: External fault 16: Communication fault 17: Contactor fault 18: Current detection fault 19: Motor auto-tuning fault 20: Encoder/PG card fault 21: Parameter read and write fault 22: AC drive hardware fault 23: Motor short circuited to ground 24: Reserved 25: Reserved	-	●
F9-16	3rd (latest) fault type	26: Accumulative running time reached 27: User-defined fault 1 28: User-defined fault 2 29: Accumulative power-on time reached 30: Load lost 31: PID feedback lost during running 40: Fast current limit timeout 41: Motor switchover error during running 42: Too large speed deviation 43: Motor over-speed 45: Motor overheat 51: Initial position error 55: Slave error in master-slave control	-	●
F9-17	Frequency upon 3rd fault	-	-	●
F9-18	Current upon 3rd fault	-	-	●
F9-19	Bus voltage upon 3rd fault	-	-	●
F9-20	DI state upon 3rd fault	-	-	●
F9-21	DO state upon 3rd fault	-	-	●
F9-22	AC drive state upon 3rd fault	-	-	●
F9-23	Power-on time upon 3rd fault	-	-	●

Appendix C

Function Code	Name	Setting Range	Default	Change
F9-24	Running time upon 3rd fault	-	-	●
F9-25	Counter electromotive force upon 3rd (latest) fault	-	-	●
F9-27	Frequency upon 2nd fault	-	-	●
F9-28	Current upon 2nd fault	-	-	●
F9-29	Bus voltage upon 2nd fault	-	-	●
F9-30	DI state upon 2nd fault	-	-	●
F9-31	DO state upon 2nd fault	-	-	●
F9-32	AC drive state upon 2nd fault	-	-	●
F9-33	Power-on time upon 2nd fault	-	-	●
F9-34	Running time upon 2nd fault	-	-	●
F9-35	Counter electromotive force upon 2nd fault	-	-	●
F9-37	Frequency upon 1st fault	-	-	●
F9-38	Current upon 1st fault	-	-	●
F9-39	Bus voltage upon 1st fault	-	-	●
F9-40	DI state upon 1st fault	-	-	●
F9-41	DO state upon 1st fault	-	-	●
F9-42	AC drive state upon 1st fault	-	-	●
F9-43	Power-on time upon 1st fault	-	-	●
F9-44	Running time upon 1st fault	-	-	●
F9-45	Counter electromotive force upon 1st fault	-	-	●
F9-47	Fault protection action selection 1	Units position: Motor overload (Err11) 0: Coast to stop 1: Stop according to the stop mode 2: Continue to run Tens position: Input phase loss (Err12) Hundreds position: Output phase loss (Err13) Thousands position: External fault (Err15) Ten thousands position: Communication fault (Err16)	00000	☆
F9-48	Fault protection action selection 2	Units position: Encoder fault (Err20) 0: Coast to stop Tens position: EEPROM read-write fault (Err21) 0: Coast to stop 1: Stop according to the stop mode Hundreds position: AC drive overload fault selection (Err10) 0: Coast to stop 1: De-rated running 2: De-rated running (only for air compressor) Thousands position: Motor overheat (Err45) Ten thousands position: Accumulative running time reached (Err26)	00000	☆

Function Code	Name	Setting Range	Default	Change
F9-49	Fault protection action selection 3	Units position: User-defined fault 1 (Err27) 0: Coast to stop 1: Stop according to the stop mode 2: Continue to run Tens position: User-defined fault 2 (Err28) 0: Coast to stop 1: Stop according to the stop mode 2: Continue to run Hundreds position: Accumulative power-on time reached (Err29) 0: Coast to stop 1: Stop according to the stop mode 2: Continue to run Thousands position: Load lost (Err30) 0: Coast to stop 1: Deceleration to stop 2: Continue to run at 7% of rated motor frequency and restore to the frequency reference if the load recovers Ten thousands position: PID feedback lost during drive running (Err31) 0: Coast to stop 1: Stop according to the stop mode 2: Continue to run	00000	☆
F9-50	Fault protection action selection 4	Units position: Too large speed feedback error (Err42) 0: Coast to stop 1: Stop according to the stop mode 2: Continue to run Tens position: Motor overspeed (Err43) Hundreds position: Initial position fault (Err51)	00000	☆
F9-54	Frequency selection for continuing to run upon fault	0: Current running frequency 1: Frequency reference 2: Frequency upper limit 3: Frequency lower limit 4: Backup frequency upon abnormality	0	☆
F9-55	Backup frequency upon fault	0.0% to 100.0% (100.0% corresponds to max. frequency (F0-10))	100.0%	☆
F9-56	Type of motor temperature sensor	0: No temperature sensor 1: PT100 2: PT1000	0	☆
F9-57	Motor overheat protection threshold	0°C to 200°C	110°C	☆
F9-58	Motor overheat pre-warning threshold	0°C to 200°C	90°C	☆
F9-59	Power dip ride-through function selection	0: Disabled 1: Bus voltage constant control 2: Decelerate to stop	0	★
F9-60	Threshold of power dip ride-through function disabled	80% to 100%	85%	★
F9-61	Judging time of bus voltage recovering from power dip	0.0s to 100.0s	0.5S	★
F9-62	Threshold of power dip ride-through function enabled	60% to 100%	80%	★

Appendix C

Function Code	Name	Setting Range	Default	Change
F9-63	Load lost protection	0: Disabled 1: Enabled	0	☆
F9-64	Load lost detection level	0.0% to 100.0%	10.0%	☆
F9-65	Load lost detection time	0.0 to 60.0s	1.0s	☆
F9-67	Overspeed detection level	0.0% to 50.0% (max. frequency)	20.0%	☆
F9-68	Overspeed detection time	0.01 to 0.600s	0.010s	☆
F9-69	Detection level of speed error	0.0% to 50.0% (maximum frequency)	20.0%	☆
F9-70	Detection time of speed error	0.0s: Not detected 0.1 to 60.0s	5.0s	☆
F9-71	Power dip ride-through gain Kp	0 to 100	40	☆
F9-72	Power dip ride-through integral coefficient Ki	0 to 100	30	☆
F9-73	Deceleration time of power dip ride-through	0 to 300.0s	20.0s	★
F9-74	UVW encoder fault (Err20) enabling	0.1	1	☆
F9-75	Fault protection action selection 5	Units position: Initial position angle identification fault (51) 0: Continue to run 1: Coast to stop Tens position: With-load auto-tuning fault (19) 0: Continue to run 1: Coast to stop	11	☆
Group FA: PID Function				
FA-00	PID reference setting channel	0: Set by FA-01 1: AI1 2: AI2 3: AI3 4: Pulse reference (DI5) 5: Serial comms. 6: Multi-reference	0	☆
FA-01	PID digital setting	0.0% to 100.0%	50.0%	☆
FA-02	PID feedback setting channel	0: AI1 1: AI2 2: AI3 3: AI1-AI2 4: Pulse reference (DI5) 5: Serial comms. 6: AI1 + AI2 7: Max. (AI1 , AI2) 8: Min. (AI1 , AI2)	0	☆
FA-03	PID operation direction	0: Forward 1: Reverse	0	☆
FA-04	PID reference and feedback range	0 to 65535	1000	☆
FA-05	Proportional gain Kp1	0.0 to 1000.0	20.0	☆
FA-06	Integral time Ti1	0.01s to 10.00s	2.00s	☆
FA-07	Differential time Td1	0.000s to 10.000s	0.000s	☆
FA-08	PID output limit in reverse direction	0.00 Hz to maximum frequency	0.00Hz	★
FA-09	PID error limit	0.0% to 100.0%	0.0%	☆
FA-10	PID differential limit	0.00% to 100.00%	0.10%	☆
FA-11	PID reference change time	0.00 to 650.00s	0.00s	☆

Function Code	Name	Setting Range	Default	Change
FA-12	PID feedback filter time	0.00 to 60.00s	0.00s	☆
FA-13	PID output filter time	0.00 to 60.00s	0.00s	☆
FA-14	Reserved	-	-	☆
FA-15	Proportional gain Kp2	0.0 to 1000.0	20.0	☆
FA-16	Integral time Ti2	0.01s to 10.00s	2.00s	☆
FA-17	Differential time Td2	0.000s to 10.000s	0.000s	☆
FA-18	PID parameter switchover condition	0: No switchover 1: Switchover via DI 2: Auto switchover based on PID error 3: Auto switchover based on running frequency	0	☆
FA-19	PID error 1 for auto switchover	0.0% to FA-20	20.0%	☆
FA-20	PID error 2 for auto switchover	FA-19 to 100.0%	80.0%	☆
FA-21	PID initial value	0.0% to 100.0%	0.0%	☆
FA-22	PID initial value active time	0.00 to 650.00s	0.00s	☆
FA-23	Reserved	-	-	-
FA-24	Reserved	-	-	-
FA-25	PID integral property	Units position: Integral separation 0: Disabled 1: Enabled Tens position: Whether to stop integral operation when the PID output reaches the limit 0: Continue integral operation 1: Stop integral operation	00	☆
FA-26	Detection level of PID feedback loss	0.0%: No detection 0.1% to 100.0%	0.0%	☆
FA-27	Detection time of PID feedback loss	0.0s to 20.0s	0.0s	☆
FA-28	Selection of PID operation at stop	0: Disabled 1: Enabled	0	☆
Group Fb: Wobble Function, Fixed Length and Count				
FB-00	Wobble setting mode	0: Relative to central frequency 1: Relative to the max. frequency	0	☆
FB-01	Wobble amplitude	0.0% to 100.0%	0.0%	☆
FB-02	Wobble step	0.0% to 50.0%	0.0%	☆
FB-03	Wobble cycle	0.1s to 3000.0s	10.0s	☆
FB-04	Triangular wave rising time coefficient	0.1% to 100.0%	50.0%	☆
FB-05	Set length	0 to 65535 m	1000 m	☆
FB-06	Actual length	0 to 65535 m	0m	☆
FB-07	Number of pulses per meter	0.1 to 6553.5	100.0	☆
FB-08	Set count value	1 to 65535	1000	☆
FB-09	Designated count value	1 to 65535	1000	☆
Group FC: Multi-Reference and Simple PLC Function				
FC-00	Reference 0	-100.0% to 100.0%	0.0%	☆
FC-01	Reference 1	-100.0% to 100.0%	0.0%	☆
FC-02	Reference 2	-100.0% to 100.0%	0.0%	☆
FC-03	Reference 3	-100.0% to 100.0%	0.0%	☆
FC-04	Reference 4	-100.0% to 100.0%	0.0%	☆
FC-05	Reference 5	-100.0% to 100.0%	0.0%	☆
FC-06	Reference 6	-100.0% to 100.0%	0.0%	☆

Appendix C

Function Code	Name	Setting Range	Default	Change
FC-07	Reference 7	-100.0% to 100.0%	0.0%	☆
FC-08	Reference 8	-100.0% to 100.0%	0.0%	☆
FC-09	Reference 9	-100.0% to 100.0%	0.0%	☆
FC-10	Reference 10	-100.0% to 100.0%	0.0%	☆
FC-11	Reference 11	-100.0% to 100.0%	0.0%	☆
FC-12	Reference 12	-100.0% to 100.0%	0.0%	☆
FC-13	Reference 13	-100.0% to 100.0%	0.0%	☆
FC-14	Reference 14	-100.0% to 100.0%	0.0%	☆
FC-15	Reference 15	-100.0% to 100.0%	0.0%	☆
FC-16	Simple PLC running mode	0: Stop after running one cycle 1: Keep final values after running one cycle 2: Repeat after running one cycle	0	☆
FC-17	Simple PLC retentive selection	Unit position: Retentive at power down 0: Not retentive 1: Retentive Tens position: Retentive at stop 0: Not retentive at stop 1: Retentive at stop	00	☆
FC-18	Running time of simple PLC reference 0	0.0s (h) to 6553.5s (h)	0.0s (h)	☆
FC-19	Acceleration/deceleration time of simple PLC reference 0	0 to 3	0	☆
FC-20	Running time of simple PLC reference 1	0.0s (h) to 6553.5s (h)	0.0s (h)	☆
FC-21	Acceleration/deceleration time of simple PLC reference 1	0 to 3	0	☆
FC-22	Running time of simple PLC reference 2	0.0s (h) to 6553.5s (h)	0.0s (h)	☆
FC-23	Acceleration/deceleration time of simple PLC reference 2	0 to 3	0	☆
FC-24	Running time of simple PLC reference 3	0.0s (h) to 6553.5s (h)	0.0s (h)	☆
FC-25	Acceleration/deceleration time of simple PLC reference 3	0 to 3	0	☆
FC-26	Running time of simple PLC reference 4	0.0s (h) to 6553.5s (h)	0.0s (h)	☆
FC-27	Acceleration/deceleration time of simple PLC reference 4	0 to 3	0	☆
FC-28	Running time of simple PLC reference 5	0.0s (h) to 6553.5s (h)	0.0s (h)	☆
FC-29	Acceleration/deceleration time of simple PLC reference 5	0 to 3	0	☆
FC-30	Running time of simple PLC reference 6	0.0s (h) to 6553.5s (h)	0.0s (h)	☆
FC-31	Acceleration/deceleration time of simple PLC reference 6	0 to 3	0	☆
FC-32	Running time of simple PLC reference 7	0.0s (h) to 6553.5s (h)	0.0s (h)	☆
FC-33	Acceleration/deceleration time of simple PLC reference 7	0 to 3	0	☆

Function Code	Name	Setting Range	Default	Change
FC-34	Running time of simple PLC reference 8	0.0s (h) to 6553.5s (h)	0.0s (h)	☆
FC-35	Acceleration/deceleration time of simple PLC reference 8	0 to 3	0	☆
FC-36	Running time of simple PLC reference 9	0.0s (h) to 6553.5s (h)	0.0s (h)	☆
FC-37	Acceleration/deceleration time of simple PLC reference 9	0 to 3	0	☆
FC-38	Running time of simple PLC reference 10	0.0s (h) to 6553.5s (h)	0.0s (h)	☆
FC-39	Acceleration/deceleration time of simple PLC reference 10	0 to 3	0	☆
FC-40	Running time of simple PLC reference 11	0.0s (h) to 6553.5s (h)	0.0s (h)	☆
FC-41	Acceleration/deceleration time of simple PLC reference 11	0 to 3	0	☆
FC-42	Running time of simple PLC reference 12	0.0s (h) to 6553.5s (h)	0.0s (h)	☆
FC-43	Acceleration/deceleration time of simple PLC reference 12	0 to 3	0	☆
FC-44	Running time of simple PLC reference 13	0.0s (h) to 6553.5s (h)	0.0s (h)	☆
FC-45	Acceleration/deceleration time of simple PLC reference 13	0 to 3	0	☆
FC-46	Running time of simple PLC reference 14	0.0s (h) to 6553.5s (h)	0.0s (h)	☆
FC-47	Acceleration/deceleration time of simple PLC reference 14	0 to 3	0	☆
FC-48	Running time of simple PLC reference 15	0.0s (h) to 6553.5s (h)	0.0s (h)	☆
FC-49	Acceleration/deceleration time of simple PLC reference 15	0 to 3	0	☆
FC-50	Time unit of simple PLC running	0: s (second) 1: h (hour)	0	☆
FC-51	Reference 0 source	0: Set by FC-00 1: AI1 2: AI2 3: AI3 4: Pulse reference 5: PID 6: Set by preset frequency (F0-08), modified via terminal UP/DOWN	0	☆

Appendix C

Function Code	Name	Setting Range	Default	Change
Group FD: Communication				
FD-00	Baud rate	Units position (Modbus) 0: 300BPS 1: 600BPS 2: 1200BPS 3: 2400BPS 4: 4800BPS 5: 9600BPS 6: 19200BPS 7: 38400BPS 8: 57600BPS 9: 115200BPS Tens position (PROFIBUS-DP) 0: 115200BPs 1: 208300BPs 2: 256000BPs 3: 512000Bps Hundreds position: Reserved Thousands position: CANlink 0: 20 1: 50 2: 100 3: 125 4: 250 5: 500 6: 1M	5005	☆
FD-01	Modbus data format symbol	0: No check <8,N,2> 1: Even parity check <8,E,1> 2: Odd parity check <8,O,1> 3: No check, data format <8,N,1> (Valid for Modbus)	0	☆
FD-02	Local address	0: Broadcast address; 1 to 247 (Valid for Modbus, PROFIBUS-DP and CANlink)	1	☆
FD-03	Modbus response delay	0 to 20 ms (Valid for Modbus)	2	☆
FD-04	Serial port communication timeout	0.0: Disabled 0.1 to 60.0s (Valid for Modbus, PROFIBUS-DP and CANopen)	0.0	☆
FD-05	Modbus protocol selection and PROFIBUS-DP data frame	Units position: Modbus 0: Non-standard Modbus protocol 1: Standard Modbus protocol Tens position: PROFIBUS-DP 0: PPO1 format 1: PPO2 format 2: PPO3 format 3: PPO5 format	30	☆
FD-06	Current resolution read by communication	0: 0.01 A (≤ 55 kW) 1: 0.1A	0	☆
FD-08	Profibus and CANopen communication timeout time	0.0 (Invalid) 0.1 to 60.0s	0	☆

Function Code	Name	Setting Range	Default	Change	
Group FE: User-Defined Parameters					
FE-00	User-defined parameter 0	F0-00 to FP-xx A0-00 to Ax-xx U0-00 to U0-xx U3-00 to U3-xx	U3-17	☆	
FE-01	User-defined parameter 1		U3-18	☆	
FE-02	User-defined parameter 2		F0.00	☆	
FE-03	User-defined parameter 3		F0.00	☆	
FE-04	User-defined parameter 4		F0.00	☆	
FE-05	User-defined parameter 5		F0.00	☆	
FE-06	User-defined parameter 6		F0.00	☆	
FE-07	User-defined parameter 7		F0.00	☆	
FE-08	User-defined parameter 8		F0.00	☆	
FE-09	User-defined parameter 9		F0.00	☆	
FE-10	User-defined parameter 10		F0.00	☆	
FE-11	User-defined parameter 11		F0.00	☆	
FE-12	User-defined parameter 12		F0.00	☆	
FE-13	User-defined parameter 13		F0.00	☆	
FE-14	User-defined parameter 14		F0.00	☆	
FE-15	User-defined parameter 15		F0.00	☆	
FE-16	User-defined parameter 16		F0.00	☆	
FE-17	User-defined parameter 17		F0.00	☆	
FE-18	User-defined parameter 18		F0.00	☆	
FE-19	User-defined parameter 19		F0.00	☆	
FE-20	User-defined parameter 20		U0-68	☆	
FE-21	User-defined parameter 21		U0-69	☆	
FE-22	User-defined parameter 22		F0.00	☆	
FE-23	User-defined parameter 23		F0.00	☆	
FE-24	User-defined parameter 24		F0.00	☆	
FE-25	User-defined parameter 25		F0.00	☆	
FE-26	User-defined parameter 26		F0.00	☆	
FE-27	User-defined parameter 27		F0.00 to FP-xx	F0.00	☆
FE-28	User-defined parameter 28		A0-00 to Ax-xx U0-00 to U0-xx	F0.00	☆
FE-29	User-defined parameter 29	U3-00 to U3-xx	F0.00	☆	
Group FP: Function Parameter Management					
FP-00	User password	0 to 65535	0	☆	
FP-01	Parameter initialization	0: No operation 01: Restore factory parameters except motor parameters 02: Clear records 04: Back up current user parameters 501: Restore user backup parameters	0	★	
FP-02	Parameter display property	Unit's digit: Group U is not displayed. 0: Not displayed 1: Displayed Ten's digit: Group A is displayed. 0: Not displayed 1: Displayed	11	★	
FP-03	Selection of individualized parameter display	Units position: Selection of user-defined parameter display 0: Not displayed 1: Displayed Tens position: Selection of user-modified parameter display 0: Not displayed 1: Displayed	00	☆	
FP-04	Selection of parameter modification	0: Disabled 1: Enabled	0	☆	

Appendix C

Function Code	Name	Setting Range	Default	Change
Group A0: Torque Control and Limit				
A0-00	Speed/Torque control selection	0: Speed control 1: Torque control	0	★
A0-01	Torque reference source in torque control	0: Set by A0-03 1: AI1 2: AI2 3: AI3 4: Pulse reference 5: Communication reference 6: Min. (AI1, AI2) 7: Max. (AI1, AI2) Full scale of 1-7 corresponds to A0-03.	0	★
A0-03	Torque digital setting in torque control	-200.0% to 200.0%	150.0%	☆
A0-05	Forward max. frequency in torque control	0.00 Hz to max. frequency	50.00Hz	☆
A0-06	Reverse max. frequency in torque control	0.00 Hz to max. frequency	50.00Hz	☆
A0-07	Acceleration time in torque control	0.00s to 65000s	0.00s	☆
A0-08	Deceleration time in torque control	0.00s to 65000s	0.00s	☆
Group A1: Virtual DI/DO				
A1-00	VDI1 function selection	0 to 59	0	★
A1-01	VDI2 function selection	0 to 59	0	★
A1-02	VDI3 function selection	0 to 59	0	★
A1-03	VDI4 function selection	0 to 59	0	★
A1-04	VDI5 function selection	0 to 59	0	★
A1-05	VDI active state setting mode	Units position: VDI1 Tens position: VDI2 Hundreds position: VDI3 Thousands position: VDI4 Ten thousands position: VDI5 0: Decided by state of VDOx 1: Decided by A1-06	00000	★
A1-06	Selection of VDI active state	0: Disabled 1: Enabled Units position: VDI1 Tens position: VDI2 Hundreds position: VDI3 Thousands position: VDI4 Ten thousands position: VDI5	00000	★
A1-07	Function selection for AI1 used as DI	0 to 59	0	★
A1-08	Function selection for AI2 used as DI	0 to 59	0	★
A1-09	Function selection for AI3 used as DI	0 to 59	0	★
A1-10	Active state selection for AI used as DI	0: High level active 1: Low level active Units position: AI1 Tens position: AI2 Hundreds position: AI3	000	★

Function Code	Name	Setting Range	Default	Change
A1-11	VDO1 function selection	0: Short with physical DIx internally 1 to 41: See physical DO selection in group F5	0	☆
A1-12	VDO2 function selection	0: Short with physical DIx internally 1 to 41: See physical DO selection in group F5	0	☆
A1-13	VDO3 function selection	0: Short with physical DIx internally 1 to 41: See physical DO selection in group F5	0	☆
A1-14	VDO4 function selection	0: Short with physical DIx internally 1 to 41: See physical DO selection in group F5	0	☆
A1-15	VDO5 function selection	0: Short with physical DIx internally 1 to 41: See physical DO selection in group F5	0	☆
A1-16	VDO1 output delay	0.0s to 3600.0s	0.0s	☆
A1-17	VDO2 output delay	0.0s to 3600.0s	0.0s	☆
A1-18	VDO3 output delay	0.0s to 3600.0s	0.0s	☆
A1-19	VDO4 output delay	0.0s to 3600.0s	0.0s	☆
A1-20	VDO5 output delay	0.0s to 3600.0s	0.0s	☆
A1-21	VDO active mode selection	0: Positive logic active 1: Negative logic active Units position: VDO1 Tens position: VDO2 Hundreds position: VDO3 Thousands position: VDO4 Ten thousands position: VDO5	00000	☆
Group A2: Motor 2 Parameters				
A2-00	Motor type selection	2: Permanent magnet synchronous motor	2	★
A2-01	Rated motor power	0.1 to 1000.0 kW	Model dependent	★
A2-02	Rated motor voltage	1 to 2000 V	Model dependent	★
A2-03	Rated motor current	0.01 to 655.35 A (AC drive power ≤ 55 kW) 0.1 to 6553.5 A (AC drive power > 55 kW)	Model dependent	★
A2-04	Rated motor frequency	0.01 Hz to max. frequency	Model dependent	★
A2-05	Rated motor speed	1 to 65535 RPM	Model dependent	★
A2-16	Stator resistance of synchronous motor	0.001 to 65.535 Ω (AC drive power ≤ 55 kW) 0.0001 to 6.5535 Ω (AC drive power > 55 kW)	Model dependent	★
A2-17	Synchronous D-axis inductance	0.01 to 6553.5 mH (AC drive power ≤ 55 kW) 0.001 to 655.35 mH (AC drive power > 55 kW)	Model dependent	★
A2-18	Q-axis inductance of synchronous motor	0.01 to 6553.5 mH (AC drive power ≤ 55 kW) 0.001 to 655.35 mH (AC drive power > 55 kW)	Model dependent	★
A2-20	Counter electromotive force coefficient of synchronous motor	0.1V to 6553.5 V	Model dependent	★
A2-27	Encoder pulses per revolution	1 to 65535	1024	★
A2-28	Encoder type	0: ABZ incremental encoder 1: UVW incremental encoder 2: Resolver 4: Wire-saving UVW encoder	0	★
A2-29	Speed feedback channel selection	0: Local PG card 1: Extension PG card 2: Pulse input (DI5)	0	★
A2-30	A/B phase sequence of ABZ incremental encoder	0: Forward 1: Reserve	0	★

Function Code	Name	Setting Range	Default	Change
A2-31	Encoder installation angle	0.0 to 359.9°	0.0°	★
A2-32	UVW phase sequence of UVW encoder	0: Forward 1: Reserve	0	★
A2-34	Number of pole pairs of resolver	1 to 65535	1	★
A2-36	Encoder wire-break fault detection time	0.0s: No detection 0.1s to 10.0s	0.0	★
A2-37	Auto-tuning selection	00: No operation 11: Synchronous auto-tuning with load 12: Synchronous auto-tuning with no-load	0	★
A2-38	Speed loop proportional gain 1	1 to 100	20	☆
A2-39	Speed loop integral time 1	0.01s to 10.00s	0.50s	☆
A2-40	Switchover frequency 1	0.00 to A2-43	5.00Hz	☆
A2-41	Speed loop proportional gain 2	1 to 100	20	☆
A2-42	Speed loop integral time 2	0.01s to 10.00s	1.00s	☆
A2-43	Switchover frequency 2	A2-40 to maximum frequency	10.00 Hz	☆
A2-47	Torque limit source in speed control	0: Set by A2-48 1: AI1 2: AI2 3: AI3 4: Pulse reference 5: Communication reference 6: Min. (AI1, AI2) 7: Max. (AI1, AI2) Full scale of 1-7 corresponds to A2-48.	0	☆
A2-48	Digital setting of torque limit in speed control	0.0% to 200.0%	150.0%	☆
A2-49	Torque limit source in speed control (regenerative)	0: Set by F2-10 1: AI1 2: AI2 3: AI3 4: Pulse setting 5: Communication setting 6: Min. (AI1, AI2) 7: Max. (AI1, AI2) 8: Set by F2-12 Full scale of 1-7 corresponds to F2-12.	0	☆
A2-50	Digital setting of torque limit in speed control (regenerative)	0.0% to 200.0%	150.0%	☆
A2-51	Excitation adjustment proportional gain	0 to 20000	2000	☆
A2-52	Excitation adjustment integral gain	0 to 20000	1300	☆
A2-53	Torque adjustment proportional gain	0 to 20000	2000	☆
A2-54	Torque adjustment integral gain	0 to 20000	1300	☆
A2-56	Flux weakening mode of synchronous motor	0,1, 2, 3	1	☆
A2-57	Flux weakening gain of synchronous motor	1 to 50	5	☆

Function Code	Name	Setting Range	Default	Change
A2-60	Regenerative power limit selection	0,1	0	☆
A2-61	Motor 2 control mode	0: SVC 1: FVC 2: V/F	0	★
A2-62	Motor 2 acceleration/ deceleration time selection	0: Same to Motor 1 1: Acceleration/Deceleration time 1 2: Acceleration/Deceleration time 2 3: Acceleration/Deceleration time 3 4: Acceleration/Deceleration time 4	0	☆
A2-66	Regenerative power limit	0% to 50%	5%	☆
A2-67	Initial position angle detection current of synchronous motor	50% to 180%	80%	☆
A2-68	Initial position angle detection of synchronous motor	0, 1, 2	0	☆
A2-70	Salient-pole rate adjustment gain of synchronous motor	50 to 500	100	☆
A2-71	MTPA control	0,1	0	☆
A2-75	Z signal correction	0,1	1	☆
A2-79	Low speed excitation current	0 to 80%	30%	☆
A2-80	Low speed frequency	0.8K to F0-15	1.5K	☆
A2-81	SVC low frequency braking mode	0,1	0	☆
A2-82	SVC low frequency braking valid frequency	0 to 10.00 Hz	2.00Hz	☆
A2-83	SVC low frequency braking change step	0.0005 to 1.0000Hz	0.0010Hz	☆
A2-84	SVC low frequency braking current	0 to 80%	50%	☆
A2-85	Synchronous motor SVC speed tracking	0 to 1	0	☆
A2-86	Zero servo enabling	0 to 1	0	☆
A2-87	Switchover frequency	0.00 to F2-02	0.30Hz	☆
A2-88	Zero servo speed loop proportional gain	1 to 100	10	☆
A2-89	Zero servo speed loop integral time	0.01s to 10.00s	0.50s	☆
A2-90	Stop anti-reversion enabling	0 to 1	0	☆
A2-91	Stop angle	0.0° to 10.0°	0.8°	☆
Group A5: Control Optimization				
A5-00	DPWM switchover frequency upper limit	5.00Hz to max. frequency	8.00Hz	☆
A5-01	PWM modulation pattern	0: Asynchronous modulation 1: Synchronous modulation	0	☆
A5-02	Dead zone compensation mode selection	0: Disabled 1: Enabled (compensation mode 1)	1	☆
A5-03	Random PWM depth	0: Random PWM invalid 1 to 10: Random PWM	0	☆
A5-04	Overcurrent fast prevention	0: Disabled 1: Enabled	1	☆

Appendix C

Function Code	Name	Setting Range	Default	Change
A5-05	Voltage over modulation coefficient	100% to 120%	110%	★
A5-06	Undervoltage threshold	120.0 to 1500.0 V	350.0V	☆
A5-08	Dead-zone time adjustment	100% to 200%	150%	★
A5-09	Overvoltage threshold	200.0V to 820.0V	820.0V	★
Group A6: AI Curve Setting				
A6-00	AI curve 4 min. input	-10.00 V to A6-02	0.00V	☆
A6-01	Corresponding percentage of AI curve 4 min. input	-100.0% to +100.0%	0.0%	☆
A6-02	AI curve 4 inflexion 1 input	A6-00 to A6-04	3.00V	☆
A6-03	Corresponding percentage of AI curve 4 inflexion 1 input	-100.0% to +100.0%	30.0%	☆
A6-04	AI curve 4 inflexion 2 input	A6-02 to A6-06	6.00V	☆
A6-05	Corresponding percentage of AI curve 4 inflexion 2 input	-100.0% to +100.0%	60.0%	☆
A6-06	AI curve 4 max. input	A6-04 to +10.00 V	10.00V	☆
A6-07	Corresponding percentage of AI curve 4 max. input	-100.0% to +100.0%	100.0%	☆
A6-08	AI curve 5 min. input	-10.00 V to A6-10	-10.00V	☆
A6-09	Corresponding percentage of AI curve 5 min. input	-100.0% to +100.0%	-100.0%	☆
A6-10	AI curve 5 inflexion 1 input	A6-08 to A6-12	-3.00V	☆
A6-11	Corresponding percentage of AI curve 5 inflexion 1 input	-100.0% to +100.0%	-30.0%	☆
A6-12	AI curve 5 inflexion 2 input	A6-10 to A6-14	3.00V	☆
A6-13	Corresponding percentage of AI curve 5 inflexion 2 input	-100.0% to +100.0%	30.0%	☆
A6-14	AI curve 5 max. input	A6-12 to 10.00 V	10.00V	☆
A6-15	Corresponding percentage of AI curve 5 max. input	-100.0% to +100.0%	100.0%	☆
A6-24	Jump point of AI1 input corresponding setting	-100.0% to 100.0%	0.0%	☆
A6-25	Jump amplitude of AI1 input corresponding setting	0.0% to 100.0%	0.5%	☆
A6-26	Jump point of AI2 input corresponding setting	-100.0% to 100.0%	0.0%	☆
A6-27	Jump amplitude of AI2 input corresponding setting	0.0% to 100.0%	0.5%	☆
A6-28	Jump point of AI3 input corresponding setting	-100.0% to 100.0%	0.0%	☆

Function Code	Name	Setting Range	Default	Change
A6-29	Jump amplitude of AI3 input corresponding setting	0.0% to 100.0%	0.5%	☆
Group A7: User Programmable Card				
A7-00	User programmable function selection	0: Disabled 1: Enabled	0	★
A7-01	Control board output terminal control mode selection	0: AC drive control 1: User programmable card control Units position: FMR (FM used as digital output) Tens position: Relay (T/A-T/B-TC) Hundreds position: DO1 Thousands position: FMP (FM used as pulse control) Ten thousands position: AO1	0	★
A7-02	Programmable card AIAO function selection	0: AI3 (voltage input), AO2 (voltage output) 1: AI3 (voltage input), AO2 (current output) 2: AI3 (current input), AO2 (voltage output) 3: AI3 (current input), AO2 (current output) 4: AI3 (PTC input), AO2 (voltage output) 5: AI3 (PTC input), AO2 (current output) 6: AI3 (PT100 input), AO2 (voltage output) 7: AI3 (PT100 input), AO2 (current output)	0	★
A7-03	PLC program controls the FMP output	0.0% to 100.0%	0.0%	☆
A7-04	Selection of PLC program controlling the AO1 output	0.0% to 100.0%	0.0%	☆
A7-05	Selection of PLC program controlling digital output	In decimal Units position: FMR Tens position: Relay 1 Hundreds position: DO	000	☆
A7-06	Setting frequency reference via the user programmable card	-100.00% to 100.00%	0.0%	☆
A7-07	Setting torque reference via the user programmable card	-200.0% to 200.0%	0.0%	☆
A7-08	Setting running command via the user programmable card	0: No command 1: Forward run 2: Reverse run 3: Forward jog 4: Reverse jog 5: Coast to stop 6: Decelerate to stop 7: Fault reset	0	☆
A7-09	Setting torque reference via the user programmable card	0: No fault 80 to 89: User-defined fault code	0	☆
Group A8: Point-point Communication				
A8-00	Point-point communication	0: Disabled 1: Enabled	0	☆
A8-01	Master or slave selection	0: Master 1: Slave	0	☆

Appendix C

Function Code	Name	Setting Range	Default	Change
A8-02	Selection of action of the slave in point-point communication	Units position: whether to follow master's command 0: No 1: Yes Tens position: whether to send fault information to master when a fault occurs 0: No 1: yes Hundreds position: whether to alarm when it becomes off-line 0: No 1: Yes (Err16)	011	★
A8-03	The slave received data	0: Torque reference 1: Frequency reference	0	☆
A8-04	Zero offset of received data (torque)	-100.00% to 100.00%	0.00%	★
A8-05	Gain of received data (torque)	-10.00 to 100.00	1.00	★
A8-06	Point-point communication interruption detection time	0.0 to 10.0s	1.0s	☆
A8-07	Master data sending cycle in point-point communication	0.001 to 10.000s	0.001s	☆
A8-11	Window width	0.20 to 10.00 Hz	0.50Hz	☆
Group AC: AI/AO Correction				
AC-00	AI1 measured voltage 1	-10.00V to 10.000V	Factory-corrected	☆
AC-01	AI1 displayed voltage 1	-10.00V to 10.000V	Factory-corrected	☆
AC-02	AI1 measured voltage 2	-10.00V to 10.000V	Factory-corrected	☆
AC-03	AI1 displayed voltage 2	-10.00V to 10.000V	Factory-corrected	☆
AC-04	AI2 measured voltage 1	-10.00V to 10.000V	Factory-corrected	☆
AC-05	AI2 displayed voltage 1	-10.00V to 10.000V	Factory-corrected	☆
AC-06	AI2 measured voltage 2	-10.00V to 10.000V	Factory-corrected	☆
AC-07	AI2 displayed voltage 2	-10.00V to 10.000V	Factory-corrected	☆
AC-08	AI3 measured voltage 1	-10.00V to 10.000V	Factory-corrected	☆
AC-09	AI3 displayed voltage 1	-10.00V to 10.000V	Factory-corrected	☆
AC-10	AI3 measured voltage 2	-10.00V to 10.000V	Factory-corrected	☆
AC-11	AI3 displayed voltage 2	-10.00V to 10.000V	Factory-corrected	☆
AC-12	AO1 target voltage 1	-10.00V to 10.000V	Factory-corrected	☆
AC-13	AO1 measured voltage 1	-10.00V to 10.000V	Factory-corrected	☆
AC-14	AO1 target voltage 2	-10.00V to 10.000V	Factory-corrected	☆
AC-15	AO1 measured voltage 2	-10.00V to 10.000V	Factory-corrected	☆

Function Code	Name	Setting Range	Default	Change
AC-16	AO2 target voltage 1	-10.00V to 10.000V	Factory-corrected	☆
AC-17	AO2 measured voltage 1	-10.00V to 10.000V	Factory-corrected	☆
AC-18	AO2 target voltage 2	-10.00V to 10.000V	Factory-corrected	☆
AC-19	AO2 measured voltage 2	-10.00V to 10.000V	Factory-corrected	☆

C.2 Monitoring Parameters

Function Code	Name	Minimum Unit	Communication Address
Group U0: Monitoring Parameters			
U0-00	Running frequency	0.01Hz	7000H
U0-01	Frequency reference	0.01Hz	7001H
U0-02	Bus voltage	0.1V	7002H
U0-03	Output voltage	1V	7003H
U0-04	Output current	0.01 A	7004H
U0-05	Output power	0.1 kW	7005H
U0-06	Output torque	0.1%	7006H
U0-07	DI state	1	7007H
U0-08	DO state	1	7008H
U0-09	AI1 voltage	0.01V	7009H
U0-10	AI2 voltage (V)/current (mA)	0.01 V/0.01 mA	700AH
U0-11	AI3 voltage	0.01V	700BH
U0-12	Count value	1	700CH
U0-13	length value	1	700DH
U0-14	Load speed display	1	700EH
U0-15	PID reference	1	700FH
U0-16	PID feedback	1	7010H
U0-17	PLC stage	1	7011H
U0-18	Pulse reference	0.01kHz	7012H
U0-19	Feedback speed	0.01Hz	7013H
U0-20	Remaining running time	0.1 Min	7014H
U0-21	AI1 voltage before correction	0.001V	7015H
U0-22	AI2 voltage (V)/ current (mA) before correction	0.001V/0.01 mA	7016H
U0-23	AI3 voltage before correction	0.001V	7017H
U0-24	Rotation speed	1 Rpm	7018H
U0-25	Current power-on time	1 Min	7019H
U0-26	Current running time	0.1 Min	701AH
U0-27	Pulse reference	1Hz	701BH
U0-28	Communication reference	0.01%	701CH
U0-29	Encoder feedback speed	0.01Hz	701DH
U0-30	Main frequency reference	0.01Hz	701EH
U0-31	Auxiliary frequency reference	0.01Hz	701FH
U0-32	Viewing any register address value	1	7020H
U0-34	Motor temperature	1°C	7022H
U0-35	Target torque	0.1%	7023H
U0-36	Resolver position	1	7024H
U0-37	Power factor angle	0.1°	7025H
U0-38	ABZ position	1	7026H
U0-39	Target voltage upon V/F separation	1V	7027H

Appendix C

Function Code	Name	Minimum Unit	Communication Address
Group U0: Monitoring Parameters			
U0-40	Output voltage upon V/F separation	1V	7028H
U0-41	DI state display	1	7029H
U0-42	DO state display	1	702AH
U0-43	DI set for function state display 1 (function 01-40)	1	702BH
U0-44	DI set for function state display 2 (function 41-80)	1	702CH
U0-45	Fault information	1	702DH
U0-58	Phase Z counting	1	703AH
U0-59	Rated frequency	0.01%	703BH
U0-60	Running frequency	0.01%	703CH
U0-61	AC drive state	1	703DH
U0-62	Current fault code	1	703EH
U0-63	Sending value of point-point communication	0.01%	703FH
U0-64	Number of slaves	1	7040H
U0-65	Torque upper limit	0.1%	7041H
U0-66	Communication extension card type	100: CANOpen 200: PROFIBUS-DP 300: CANlink	7042H
U0-67	Communication extension card version	Display Range	-
U0-68	AC drive state on DP card	Bit0: AC drive running status Bit1: Running direction Bit2: Whether the drive has a fault Bit3: Target frequency reached Bit4 to Bit7: Reserved Bit8 to Bit15: Fault code	7043H
U0-69	Speed of transmitting DP/0.01 Hz	0.00 Hz to maximum frequency	7044H
U0-70	Motor speed of transmitting DP/RMP	0 to rated motor	7045H
U0-71	Communication card current display	Display Range	-
U0-72	Communication card faulty state	Display Range	-
U0-73	Motor SN	0: Motor 1 1: Motor 2	7046H
U0-74	Counter electromotive force	0.1V	704AH
U0-75	AC drive dormant state	0	704BH
U0-76	Low bits of accumulative power consumption	0.0 to 999.9	704CH
U0-77	High bits of accumulative power consumption	0 to 65535	704DH
U0-78	Linear speed	1 m/Min	704EH

