

MD810 Series – AC MultiDrives 400 V

For multi-sectional drives applications

- Open and closed loop control
- For induction and permanent magnet synchronous motors
- Single drive modules: 1.5 to 160 kW
- Dual drive modules: 1.5 to 18.5 kW



MD810 features and functions

Designed for sectional applications

MD810 is a modular, scalable, easy-to-use product designed for industrial applications requiring complex multidrive systems.

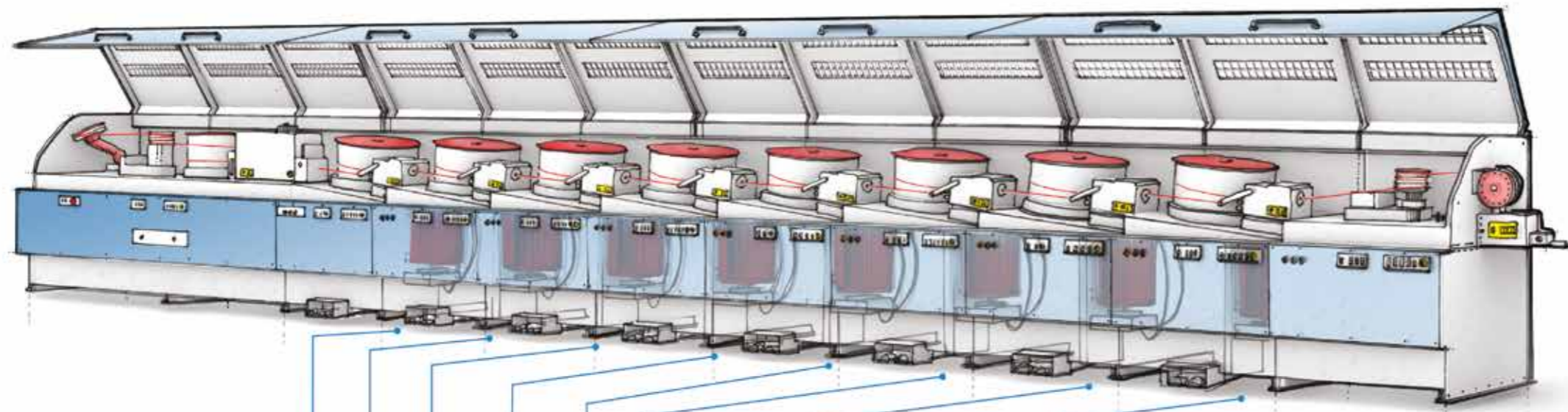

- ✓ Reduced installation costs
- ✓ Energy saving
- ✓ Functional safety - STO SIL3
- ✓ Easy & flexible integration
- ✓ Multiple control modes
- ✓ Advanced functionality
- ✓ Easy commissioning & maintenance
- ✓ Designed to be durable



Combined with a common rectifier, MD810 forms a multidrive system for complex sectional machines, such as wire drawing, metal processing, calender, textile and chemical fiber machinery.

MD810 offers a modular design and a common frame size, making it scalable and easy to use.

For machines requiring multi-axes servo control, MD810 was designed to work seamlessly with the IS810 servo drive, which matches the common frame size.

Peer-to-Peer functionality is included on the drive as standard and includes speed/position control, load sharing, droop control, and tension control.

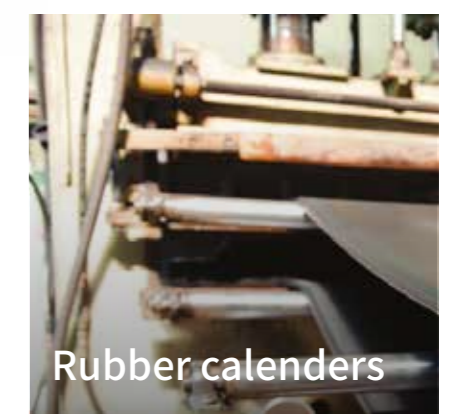
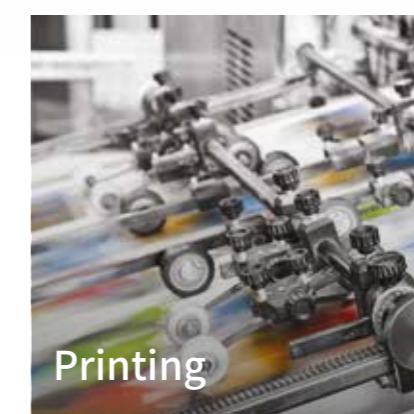

MD810 features and functions

Fast installation and commissioning | Easy maintenance | Durability | Energy savings | Reduced cabinet size | Fewer external components

Energy savings

- Common DC bus configuration allows sharing of regenerated energy
- Centralized braking design enables braking energy to be reused

Durability in harsh environments

- Class 3C2 & 3S2 conformal coating
- Separate cooling channel for heatsink prevents dust contamination of internal PCBs
- Applicable ambient temperature range
 - Operation: -10 - 50°C
 - Storage: -25 - 70°C
- Humidity range of 5%-95% (60% in case of corrosive gas)
- Cost-effective, built-in DC reactors for smooth current flow and reduced harmonic distortion
- Overload: 150% (for 60 s); 178% (for 2 s)

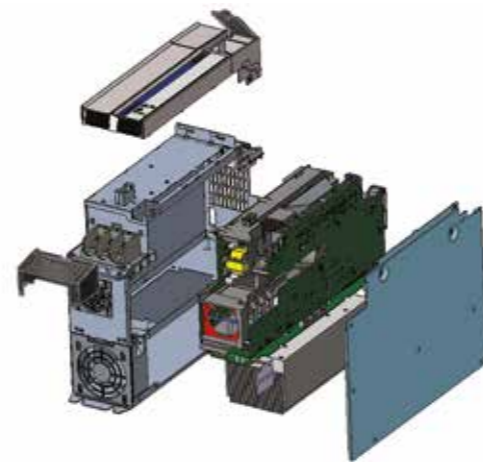

MD810 is designed to perform in the harshest of industrial environments

Easy maintenance

- Common sizes for each power segment enables fewer inventory components to be stored in customer warehouses
- DC soft charge module enables drive to be independently powered on or off
- Built in redundancy: if one rectifier fails, the system can continue operation with reduced capacity (reduced speed and/or load)
- PLC/HMI/drive software configured through the same network for simple maintenance and lower maintenance costs
- Software integrates all steps for commissioning, diagnostics & maintenance

Reduced cabinet size

- Improved power efficiency results in a smaller cabinet due to reduced rectifier capacity and reduced braking units
- Through-hole mounting further reduces cabinet size/volume
- Compact “2 in 1” dual drive module available for ratings from 1.5 to 18.5 kW



Fast, easy installation and commissioning

- Simple, plug & play module installation
 - DC bus connection accessible from the front for easy module installation
 - Safe Torque Off (STO) function eliminates need for output contactors
 - Fewer specialist workers required for installation
 - Rapid module replacement when needed
- One-click network connection with InoDriveShop (see p8)
- Optimized wiring and commissioning
 - One PLC connection cable
 - One group of input power cables
 - One remote keypad with one cable connects to multiple drives
- Fewer external components: built-in mini bus bars and common DC bus configuration enables elimination of external supply components (individual protections, braking units and resistors)
- Compatible with open communication fieldbuses like PROFINET, PROFIBUS DP and CANopen

MD810 features and functions

MD810 is a multidrive system for induction and PMS motors.

- Control modes:
 - V/f for open loop induction motors
 - SVC for open loop induction and PMS motors
 - FVC for closed loop induction and PMS motors
- Capacity range: 1.5-160 kW (1.5-18.5 kW for dual drive “2 in 1” modules)
- 3 ph 380-480 VAC voltage supply range
- TN and TT supply
- 24 V auxiliary control supply
- Maximum output frequency 500 Hz
- IP20 (IP00 for 355 kW power supply)
- Built-in dynamic brake (for 22 & 45 kW rectifiers)
- Built-in English language LED keypad
 - Optional remote keypad with 8 GB SD card
 - Only one keypad needed for multiple drives
 - Parameter copying capability
- Static and dynamic autotuning
- Second PID control for external devices

Size 1 dual drive module
- front covers removed



Size 1
dual ratings available:
1.5, 2.2, 3.7 & 5.5 kW

Size 2 dual drive module
- front covers removed



Size 2
dual ratings available:
7.5, 11, 15 & 18.5 kW

- Range of peer to peer control modes:
 - Speed/position control
 - Load distribution control
 - Droop control
 - Tension control
- Center winder/unwinder functionality
- Textile wobble control included as standard
- Communication protocols:
 - Modbus-RTU
 - CANopen
 - CANlink
 - PROFIBUS DP
 - PROFIBUS DP-to-CANopen gateway
 - PROFINET-to-CANopen gateway
- PSU unit available from 22 to 355 kW
- Switching frequency up to 12 kHz
- Safe Torque Off (STO) SIL3 (EN 61800-5-2)
- Feedback technologies supported:
 - Resolver
 - ABZ incremental encoders
 - 23 bit serial encoder – unique proprietary Inovance product



PC software tools

InoDriveShop

InoDriveShop is Inovance's PC-based software offering. It is based on a familiar Windows™ interface. InoDriveShop can upload and download drive parameters, and features a variety of other functions, such as a real-time oscilloscope.

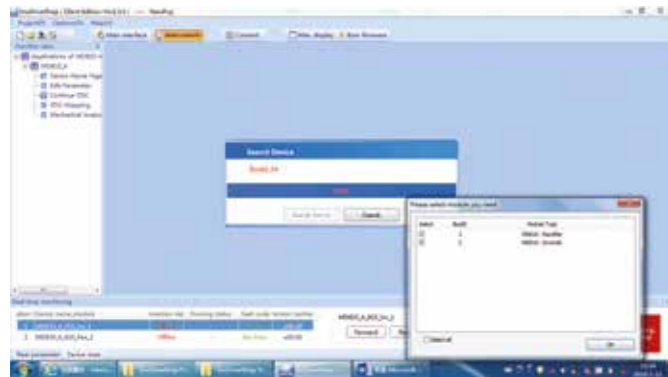

One key module scanning



Parameter uploading/downloading in batches

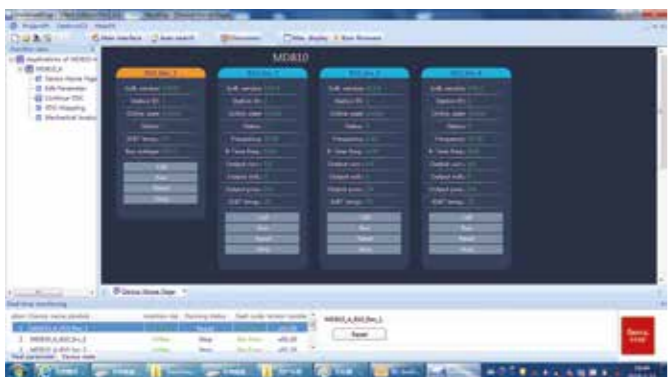

Visualisation of modules' status

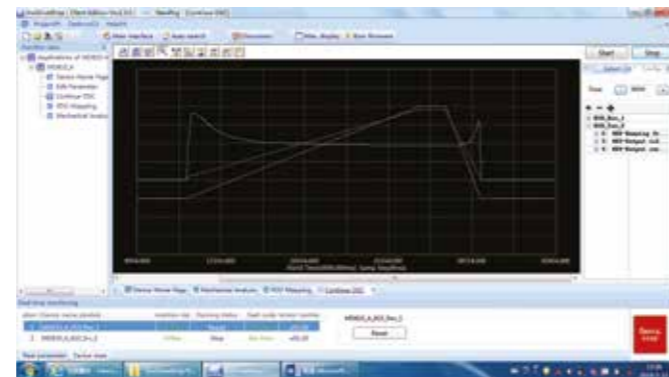

Multi-drive, multi channel oscilloscope

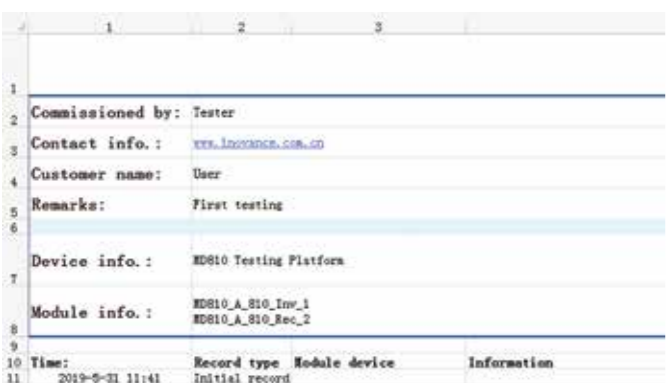

Commissioning record

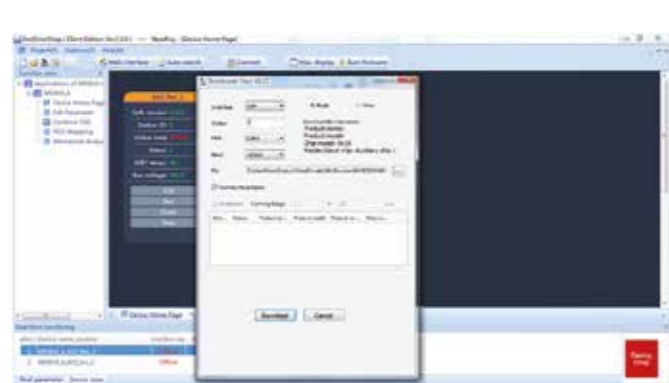

Online software upgrade

✓ PROFIBUS DP communication settings can also be checked and configured

MD810 technical data

Product ordering code



MD810 - 20M 4T 45 G 1 0 0

① ② ③ ④ ⑤ ⑥ ⑦ ⑧

- ① AC drive series
- ② **Module type:**
20M: rectifier
50M: drive
- ③ **Voltage supply:**
4T: 380–480 V
- ④ **Rectifier (rated power):**
22: 22 kW
45: 45 kW
110: 110 kW
160: 160 kW
355: 355 kW
- ⑤ **Model**
G: general model
- ⑥ **Optional functional component**
Rectifier:
0: without built-in brake
1: with built-in brake (22 & 45 kW only)
Drive:
2: built-in differential PG card
3: built-in 23 bit absolute PG card
4: built-in resolver + frequency division card
- ⑦ **Optional communication component**
Rectifier:
0: built-in RS485 (Modbus-RTU), CANopen and CANlink communications
1: built-in CANopen, CANlink, PROFIBUS-DP and PROFIBUS DP gateway to CANopen communications
Drive:
0: built-in RS485 (Modbus-RTU), CANopen and CANlink communications
1: built-in CANopen, CANlink and PROFIBUS-DP communications
- ⑧ **Optional features**
Drive:
0: no optional features
1: built-in STO (pending for drives of 90 kW and above)
Rectifier:
0: no optional features available

MD810 Ratings Single drives

Drive unit model	Rated power (kW)	Input DC current (A)	Output AC current (A)
537–679 VDC (working range: 350–800 VDC) Output voltage: 0–480 VAC			
MD810-50M4T1.5GXXX	1.5	4.9	3.8
MD810-50M4T2.2GXXX	2.2	7	5.1
MD810-50M4T3.7GXXX	3.7	12	9
MD810-50M4T5.5GXXX	5.5	17	13
MD810-50M4T7.5GXXX	7.5	22	17
MD810-50M4T11GXXX	11	31	25
MD810-50M4T15GXXX	15	40	32
MD810-50M4T18.5GXXX	18.5	46	37
MD810-50M4T22GXXX	22	55	45
MD810-50M4T30GXXX	30	73	60
MD810-50M4T37GXXX	37	90	75
MD810-50M4T45GXXX	45	105	91
MD810-50M4T55GXXX	55	129	112
MD810-50M4T75GXXX	75	172	150
MD810-50M4T90GXXX	90	294	184
MD810-50M4T110GXXX	110	358	224
MD810-50M4T132GXXX	132	420	262
MD810-50M4T160GXXX	160	474	296

Dual drives

Drive unit model	Rated power (kW)	Input DC current (A)	Output AC current (A)
537–679 VDC (working range: 350–800 VDC) Output voltage: 0–480 VAC			
MD810-50M4TD1.5GXXX	1.5	10	3.8
MD810-50M4TD2.2GXXX	2.2	14	5.1
MD810-50M4TD3.7GXXX	3.7	24	9
MD810-50M4TD5.5GXXX	5.5	34	13
MD810-50M4TD7.5GXXX	7.5	44	17
MD810-50M4TD11GXXX	11	62	25
MD810-50M4TD15GXXX	15	80	32
MD810-50M4TD18.5GXXX	18.5	92	37

Rectifiers

Rectifier unit model	Rated power (kW)	Input AC current (A)	Output DC current (A)	Braking unit
380–480 VAC (working range: 323–528 VAC) Output voltage: 537–679 VDC				
MD810-20M4T22GXXX	22	59	56	Built-in
MD810-20M4T45GXXX	45	112	110	Built-in
MD810-20M4T110GXXX	110	196	240	MDBUN-60-(5)T*2
MD810-20M4T160GXXX	160	292	358	MDBUN-90-(5)T*2
MD810-20M4T355GXXX	355	619	759	MDBUN-200-C/B*3

Overview of MD810 series AC drives

Dimensions of single drive units

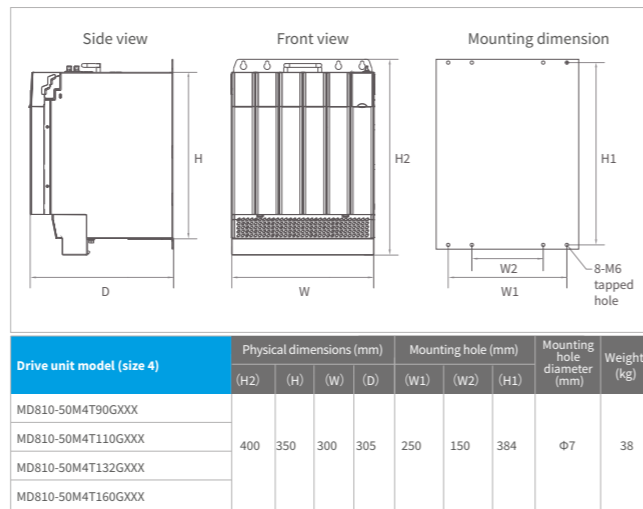
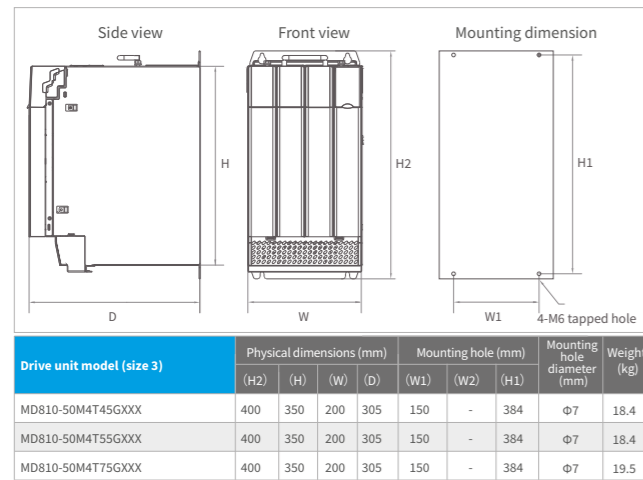
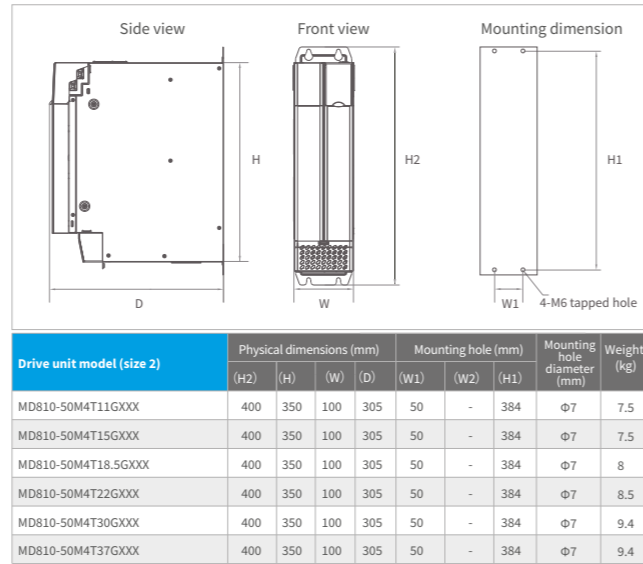
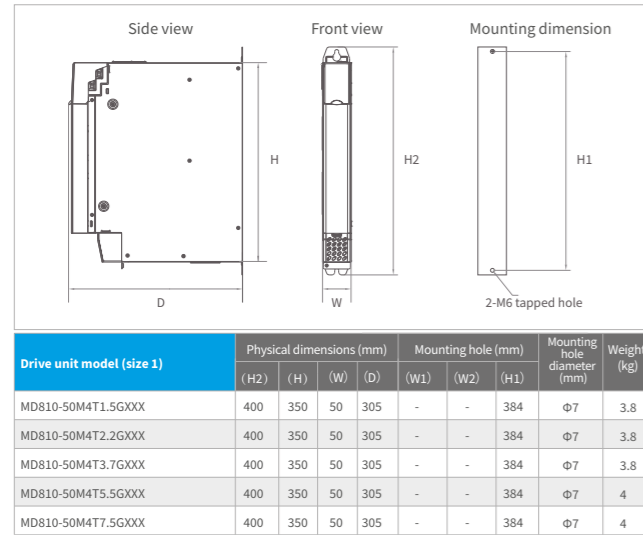

Dimensions of dual drive units

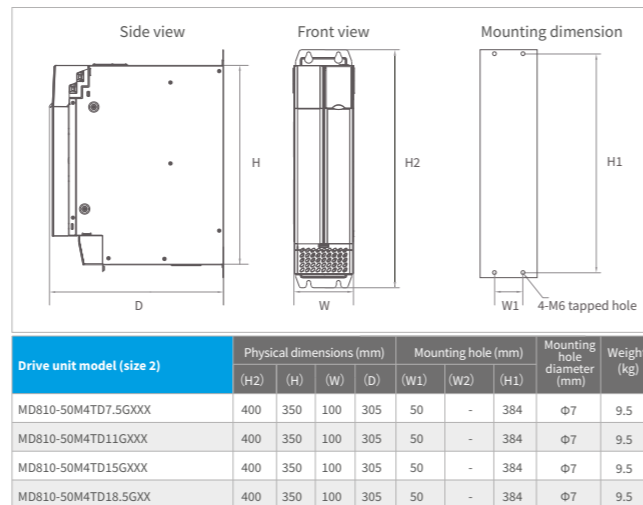
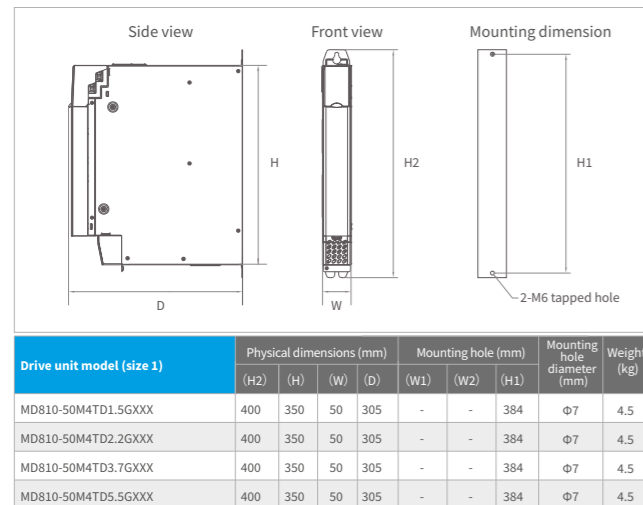

Dimensions of rectifier units

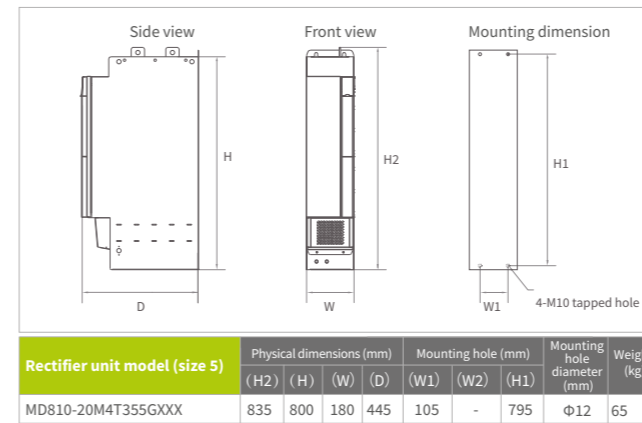
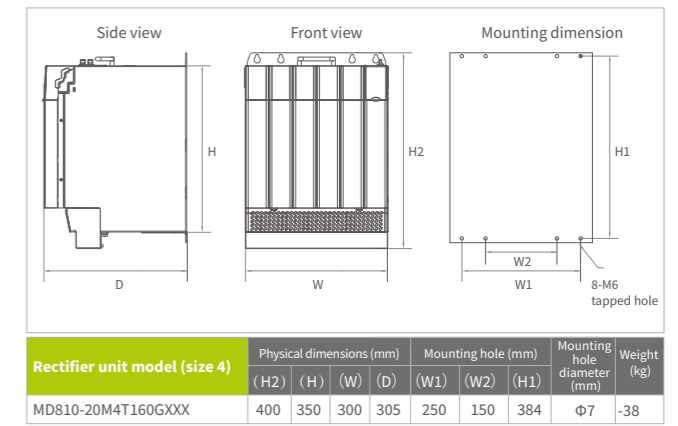
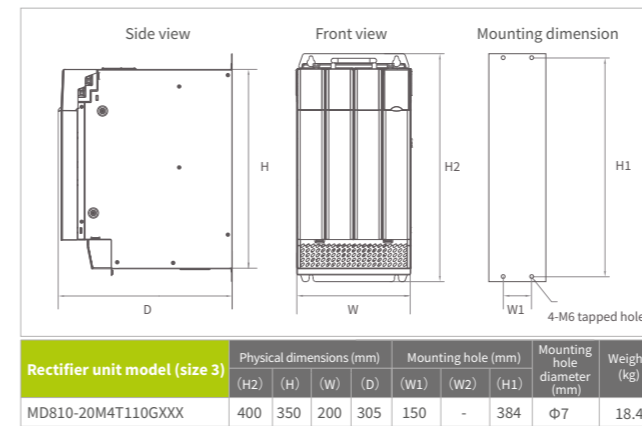
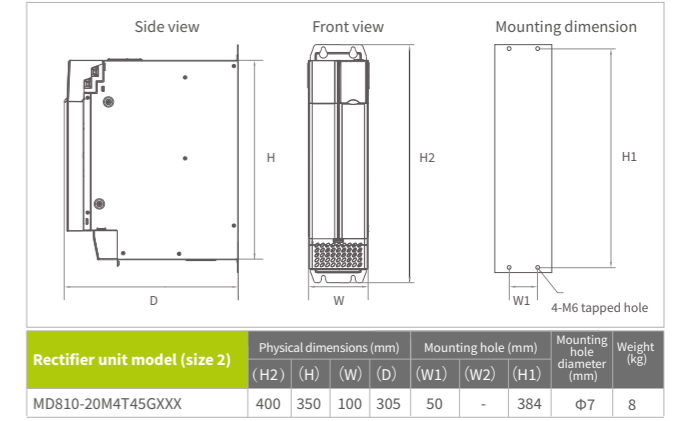
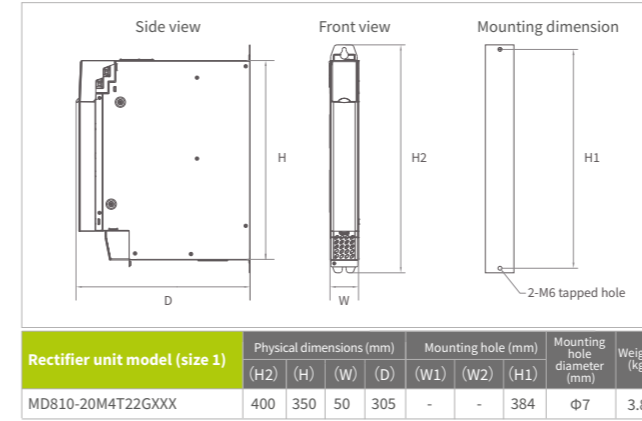

MD810 accessories

Applicable model	MD810 accessory	
	Type code	Description
Size 1 (W: 50 mm)	MD810-AZJ50M-W1	Through-hole mounting brackets for PSU and Drives
Size 2 (W: 100 mm)	MD810-AZJ50M-W2	
Size 3 (W: 200 mm)	MD810-AZJ50M-W3	
Size 4 (W: 300 mm)	MD810-AZJ50M-W4	
Size 1 (W: 50 mm)	MD810-PBJ50M-W1	Cable support bracket for PSU and Drives
Size 2 (W: 100 mm)	MD810-PBJ50M-W2	
Size 3 (W: 200 mm)	MD810-PBJ50M-W3	
Size 4 (W: 300 mm)	MD810-PBJ50M-W4	
Size 1 (W: 50 mm)	MD810-DLB-W1	Air guide plate for PSU and Drives
Size 2 (W: 100 mm)	MD810-DLB-W2	
Size 3 (W: 200 mm)	MD810-DLB-W3	
Size 4 (W: 300 mm)	MD810-DLB-W4	
PSU (sizes 1-2), Drives (size 1)	MD810-CON1	Additional DC bus terminals for PSU and Drives
PSU (sizes 3-4), Drives (sizes 2-4)	MD810-CON2	
Size 1 (W: 50 mm)	C45590-GNCN-C2500024	Communication (Modbus-RTU, CANopen) cable (RJ45 connectors) between modules
Size 2 (W: 100 mm)	C45590-GNCN-C2500025	
Size 3 (W: 200 mm)	C45590-GNCN-C2500035	
Size 4 (W: 300 mm)	C45590-GNCN-C2500055	
Size 5 (355 kW PSU)	C45590-GNCN-C2500080	
Single: 1.5-7.5 kW, Dual: 1.5-5.5 kW	INOV-SU-30	Soft-charging unit for drive modules (single: 1.5-7.5 kW, dual: 1.5-5.5 kW)
Single: 11-22 kW, Dual: 7.5-11 kW	INOV-SU-60	
Single: 30-37 kW, Dual: 15-18.5 kW	INOV-SU-100	
Single: 45-75 kW	INOV-SU-170	
Single: 90-160 kW	-	
All	SOP-20-810	Remote LCD keypad (including 3 m cable)
All	C45590-GNCN-C25003	Remote LCD keypad spare cable (3 m)
All	SOP-20-MP-IP20	LCD keypad mounting base for installation on cabinet door

Driven by Technology

AC Drives



AC MultiDrives



MV Drives



Single-Axis Servos



Multi-Axis Servos



Robotics & Motion Controllers



PLCs & HMIs



CNC Machine Tool Solutions



Electric Vehicle Inverters

